

# MASCOT

THE MAGAZINE OF THE MIDGET & SPRITE CLUB

ISSUE 426 SEPTEMBER 2019

£3

## WILTS AREA ENJOY SUMMER DRIVING



OUTSTANDING CLUB  
MAGAZINE OF  
THE YEAR 2018  
HIGHLY COMMENDED



[www.midgetandspriteclub.co.uk](http://www.midgetandspriteclub.co.uk)



**A VISIT TO BHM** BY MEMBER, GARY MORRIS

**HAZARDS PT 2** BY DR JOHN

ALSO IN THIS ISSUE: **FIVE IN A MIDGET** • **LOTON HILLCLIMB** • **SILVERSTONE CLASSIC**

# Got a classic policy? RH guarantees to beat your everyday car's renewal too!

by Emma Airey, Head of RH Specialist vehicle insurance

## If RH is already insuring your specialist vehicle, they will quote 10% less than the renewal premium for your everyday private car\*.

RH is best known for its specialist vehicle insurance, but they also provide highly competitive cover to owners of modern cars, along with the pleasing bonus of old-fashioned personal service.

But that's not all.

RH's fees for swapping vehicles, policy changes or mid-term adjustments are easy to understand: they're £0.

Legal cover is a bargain too – if you're already paying legal expenses cover (£10.50) for one car with RH, you can add as many vehicles as you like to your multi-vehicle policy, with no additional legal expenses cover payable. The cover will apply to all vehicles, with no limit on the total number of vehicles, or the mix of moderns to classics. In addition, every vehicle you add to the policy will earn its own multi-vehicle discount.



There's even more good news, as **UK and European breakdown recovery is standard with the RH package** – for classic and modern vehicles.

\*You'll need to meet RH's standard underwriting criteria and be claim-free in the last 12 months. Your current premium will need to match or exceed RH's minimum premium (£240), which is periodically subject to change. As long as the cover is 'like for like' – that is, directly comparable\*\*, it's all good! Even if your renewal date is the best part of a year away, RH would be delighted to chat to you now about tailoring some top-notch, cost-effective cover.\*\*\*

\*\*RH reserves the right to request sight of your renewal notice for validation purposes.

\*\*\*A change in your circumstances could impact any quotes previously provided.

Call any of the friendly team members on  
**0333 043 3911**  
or email [classicuw@ers.com](mailto:classicuw@ers.com)



A HISCOX COMPANY

# WELCOME TO THE SEPTEMBER EDITION OF MASCOT

NEIL THOMAS

editor@midgetandspriteclub.co.uk



Hello MASC members, hope this last month has been kind to you. I know some of you have had the most fantastic weather, whilst others of you have needed an ark. Typical British weather, I say and variations that we have seen countless times in the past although people's memories of it fade.

I must confess that this issue has been the most challenging of my editorship as the usual write ups sent in by members just dried up. Apart from the stalwart Area Rep submissions, I had very little to include. This required an urgent response and so our webmaster, Mike, kindly created a group email for me with an appeal from myself for material. Thank heavens it worked as normal service was resumed. I had a number of technical articles submitted to me along with member's adventures. I have not been able to include them all in this issue but have stored them for future inclusion. I am most grateful to the response to this rallying call.

I have been trying to rack my brain as to what had changed to create this situation but can find no specific reason, other than members have been so busy with their cars that they had no time to commit pen to paper. When I look at the MASC Facebook site I could see lots of events being attended and photos being posted up, but that is where



they stayed. The unfortunate thing is that I would challenge a guess that only a small proportion of our MASC actual members are on Facebook and because we allow non members access to the Facebook page, it is they who are getting the benefit of the photos primarily and not those paying their MASC membership. My editorial of last month raised a question over membership and this month's "Dear MASCOT" includes a couple of responses. What do you think? Let me know please, but not via Facebook please. An email would be preferred.

As your current editor, and as previous editors will attest, it is a very time consuming and challenging role. It takes me 20-30 hours a month to put MASCOT together and I can't do it without you. You are MASC. I need your stories, your adventures, your trips out, your holidays, your rebuilds and all other things Spridget related. You don't need to rely on your area rep to submit material (as some don't anyway), but you can send me items yourselves. I will include them in an issue of MASCOT. I promise.

Unfortunately, this month, MASCOT will be arriving later than usual due to these issues. So many of you love to receive the magazine, lets not let it fade away. It's too good for that.

Lastly, please see the flyer for the NEC show in November. The discount code is there for you so book your tickets and come and see us on the stand and if you want to help out, let Alan Pritchett know. I am sure he would welcome your support.

**Until next month, drive safely. Neil**

## WILTS AREA ENJOY SUMMER DRIVING



The statements and opinions expressed in each and every issue of Mascot are not necessarily the considered views of the Midget and Sprite Club. The views expressed by the editorial contributors, letter writers and advertisers are their own and do not necessarily reflect the view of the Club. The Midget and Sprite Club accepts no responsibility for the results of following contributor's advice, nor does it necessarily endorse the services or products offered by advertisers.

THE DEADLINE FOR ARTICLES AND REPORTS TO BE INCLUDED IN THE **OCTOBER** EDITION OF MASCOT IS...

**MONDAY 9TH  
OF SEPTEMBER**

# EVENTS CALENDAR 2019

- 9 September MASC Track Day, Castle Combe courtesy of MGOT
- 22 September York Historic Vehicle Group 42nd Annual Rally - on The Knavesmire at York Racecourse. We will have the Club tent and would love to have a few cars displayed. £5 per car entry in advance by 10th September. Please contact us on 07471 606060 or 07484 682516 if you are interested.
- 12 October Halls Garage (Tifosi Car Company) are having an Open Day on the 2019. From 11 O'clock onwards.
- 26 October AGM, RAF Cosford
- 8-10 November NEC Classic Car Show.

Send your events details to [editor@midgetandspriteclub.co.uk](mailto:editor@midgetandspriteclub.co.uk)  
Area Reps, Please remember that you can now add your monthly events on the Club's website.  
Please contact Mike [webmaster@midgetandspriteclub.co.uk](mailto:webmaster@midgetandspriteclub.co.uk)

## EVENTS DETAILS NEEDED FOR 2019

Area reps please make Neil Thomas aware of any events already in your diaries and any that are planned for 2019 so that they can be added to this section of the magazine and the website.

For the magazine Neil can be contacted at [editor@midgetandspriteclub.co.uk](mailto:editor@midgetandspriteclub.co.uk)  
For the website Mike Bennett can be contacted at [webmaster@midgetandspriteclub.co.uk](mailto:webmaster@midgetandspriteclub.co.uk)

## REGALIA

All available on line, along with other items at:  
[www.midgetandspriteclub.co.uk](http://www.midgetandspriteclub.co.uk)



**Binders**  
£6.50



**Key fobs**  
£3.25

**DVD**  
£12



**Golf umbrellas**  
from £19.19 plus p&p



**Grille badges** £21

**Badge Bar badges now in stock, £21**



**Window sticker**  
£2 inc p&p

**Cloth badge** £3.25  
inc p&p



# THE UK'S BIGGEST & BEST CLASSIC MOTOR SHOW

3,000 CLASSIC CARS | 300 VEHICLE CLUBS | 3 DAYS

The definitive destination for classic car appreciation



NEC Birmingham | 8 -10 November 2019

Join us for a great day out exploring 3,000 cars, 300 fellow vehicle clubs, a host of celebrities, the UK's largest indoor autojumble, hundreds of specialist exhibitors, demonstrations, auction, competitions and more!

Exclusive discount on adult or family tickets on Saturday and Sunday with your club code\*: **CC5940**

## BOOK YOUR TICKETS TODAY

[necclassicmotorshow.com/club-tickets](http://necclassicmotorshow.com/club-tickets)

Headline Sponsor



Official Partners



\*Exclusive discount code is for club members use only, available in advance until midnight on Thursday 7 November 2019. To book by phone call 0871 230 1088, calls cost 13ppm plus network extras.



JULY > AUGUST 2019

# NEW MEMBERS

We extend a warm welcome to the following new and rejoined members

5912	Joseph Olivelle	Essex	Sprite	
5913	John Dewberry	Kent	Midget	Mk 3
5914	Kevin & Karen Butt	Somerset	none	None
5915	Julian Winters	Suffolk	Midget	None
5916	Chris Hall	Essex	Sprite	Mk 1
5917	Van Tran	Notts	Midget	Mk 3
5918	Ian Tappenden	Devon	Midget	1500
5919	Ken Erdmann	USA	Midget	Mk 2



This is my red Frogeye Sprite.  
Chris Hall



**NEW!**  
**145R13 CA67**  
Pirelli Cinturato  
The only classic  
tyre in its size



+44(0)1302 711123  
[www.longstonetyres.co.uk](http://www.longstonetyres.co.uk)

# SNAP! OF THE MONTH

To submit your photo by email to [editor@midgetandspriteclub.co.uk](mailto:editor@midgetandspriteclub.co.uk) (jpeg, max file size 5MB)



Chris Banton at Goodwood



# SNAP!

# LOTON PARK HILL CLIMB



The 24th/25th August 2019 saw the Loton Park Hillclimb, near Shrewsbury, take place on a very hot August Bank Holiday. I was there to compete, on the Sunday, in my 1964 K series Midget, "Betty Boop". This was a round of the MG Car Club Speed Championship. I had travelled up on the Saturday with my good friend Mark, also from Pembrokeshire. We had escaped family commitments for the weekend, choosing to pay the £9 camping fee to stay in the deer laden park adjacent to the track. Arriving at 4pm in the afternoon, we soon had the tent up and a Brew Dog open. A walk around the pits gave us a chance to look at the cars present and say hello to a few familiar faces, including our own Wilts Area Rep, Andy Cross. Food beckoned and the barby was lit whilst we watched numerous hot air balloons take flight across the valley towards Oswestry. It was a perfect warm and balmy evening and a walk up the hill helped me refresh my memory of this quite challenging hillclimb.

Of course, how Loton Park became a hillclimb venue, is interesting.

It was used by the War Department for munitions storage during WWII. By the time they vacated the site in 1959, the army had laid around 14 miles of roads throughout the deer park. Sir Michael Leighton, who had taken over the estate after his father's death and members of the Shrewsbury based Severn Valley Motor Club, saw the potential of these tarmac tracks and a course was created. RAC approval was applied for in time for the first meeting in June 1960 followed by another later that summer. Loton was given 'Restricted' status in 1961, enabling members of other invited clubs to take part in events. The first ever winner was Peter Foulkes in a Cooper Climax. Loton eventually hosted a Championship-round in 1963 when Tony Marsh set the record on the new hill with a time of 37.03 seconds driving his Marsh Special.

By the late '60s the course measured 1475 yards, making it the third longest course used in the British Hill Climb Championship. In 1970, Peter



Blankstone had set the first ever BTD on this new layout in the Brabham with Marsh-Hewland 4WD. By April 1970, Hagley & District Light Car Club had taken over the running of Loton Park events. Hill climbing legend, Roy Lane set BTD 15 times at Loton throughout his career. The hill record of 43.52 seconds is currently held by 6-times British Champion, Scott Moran from Ludlow who set the mark on June 10th 2012 driving his famous Gould GR61X.

I wouldn't be setting times like these of course and when my head hit the pillow, I could only dream of such speedy finishes.

Sunday dawned like a typical Summers morning, with mist hanging low in the valleys and signs that deer had been examining our tent overnight. Following breakfast we packed our gear and got the car ready for the day's driving. No 157 was my number allocation and I lined up between a TA and a very quick lightweight Midget with slick boots. There were other MG's in our group 4 too including V8's, other Midgets, B's, TC's and a ZR. 15 MG's in total. Scrutineering came and went and soon it was our turn to line up for the start. I'm always nervous at this stage with butterflies in my stomach. However once the green lights appear I forget all that and drive as quick as I can. First practice produced 69.92, second practice 66.49, first official timed run, 66.09 and my last timed run, 66.97. I must confess that I was a little disappointed as on my last visit here in 2017, my best run was 65.25. New tyres needed perhaps?

It wasn't all bad however as I had the third quickest time of the group with only the race prepared Midget (62.99) and MGB (65.66), both on slicks, ahead of me. The nearest next Midget was 67.85 (on slicks), an MGB on 67.08, the MGB V8 on 67.86 and other slower cars behind.

It was great to see MASC member Steve Goodchild at the meeting. Steve had driven up from Reading to watch with his good friend Pete. My son Alex had also driven up from Cambridge to see me compete. In was sad to see him leave as the following Thursday he was leaving the UK to make his new home in the United States with his lovely wife



Katie. I must admit I found that goodbye, difficult.

Mark and I soon packed up our belongings and with the car on the trailer we headed back for the South Wales Riviera, well Tenby that is, on our 3 hour journey.

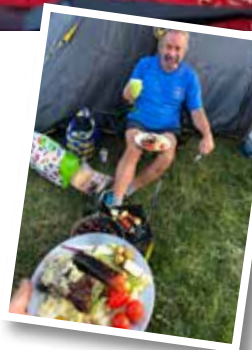

It had been a great little outing and both of us had thoroughly enjoyed it. Importantly also, "Betty Boop" was still in one piece. Her next outing will be at Castle Coombe on Monday 9th September for the MG's on Track event, supported by MASC. See you there perhaps.

## Neil



# WILTSHIRE AREA ACTION....



These are the busiest days of the year for the lucky ones among us who have mobile Sprites and Midgets, and we seem to be making the most of it. I've managed to get out in all extreme weathers in my Mk II Sprite, and even managed a pitstop to change to a 3.9 diff, rebuild the propshaft and paint the garage floor.

As a quick update since our earlier summer meets at The Barge, we have had various Sprite and Midget outings. First was the brilliant Aquae Sulis (Bath Motor Club) tour, which covered a superb variety of roads around parts of Somerset and Wiltshire that were a gift for our cars, but included sufficient challenges to keep navigators on their wits and the treats of lunch at Montacute House, The interesting Hill Brush Factory and its wonderful cafe for tea and finishing at Orchardleigh for a tasty roast dinner. Since then members have attended a Castle Combe classic race meeting, the Market Lavington vintage gathering, the Atwell Wilson Museum open day, a Gurston Down Hill Climb, and, outside of Wiltshire, the Chateau Impney Hill Climb, the Val des Terres Hill Climb on Guernsey, and the Silverstone Classic race meeting. Then, back into our favourite county for the Dick Mayo sprint at

Castle Combe, the Bristol Motor Club family day for classic cars, also at Castle Combe, and the giant old vehicle gathering at the George Inn at Longbridge Deverill. The Wiltshire MASC flag has been raised many times, and some of us are as exhausted as our cars!

Both our local members competing regularly in hill climbs have tasted success, with wins for Colin Gale at Castle Combe and for Keith Wilson at Gurston Down, but Colin's win lost its sweetness when his engine went "bonk" at the start of the last run. There's a lesson there for us all, but I'll leave you to try guessing what it was after a look at the attached picture. Sorry Colin!

Still, there has been more excitement, and it's turning out to be a scorching summer. A few MASC gardening enthusiasts went to inspect a lovely house and garden in Corsham, Middlewick House. Once owned by Camilla (yes, Duchess of Cornwall), it's now the home of Nick and Annette Mason, he of Pink Floyd and an enviable car obsession. Nick has a habit of parking some of his superb wheeled collection on the manicured lawns, to give us an alternative to inspecting his gladioli, so it's always doubly enjoyable.



Oooh that gorgeous multi million Ferrari 250GT was there, of course, a stunning car, and I was tempted to “borrow” one of its wipers, having just lost an identical one from Mildred in a recent monsoon. I resisted, of course, and I’ve ordered my own now.

Then there was the Devizes Motor Club’s Valleys and Villages tour, and some MASC members on this discovered many of the county’s best roads, whoopee! But I’ll insist we found even better Spridget-style tarmac in our own MASC Wiltshire and Bristol group runs to Imber, via Marlborough and our many White Horses. This put plenty of wind in our hair, and the long convoy of sporty Sprites and Midgets woke up a string of sleepy villages, arriving at Imber, which has slept unoccupied for many years, before lunch. The village was evacuated in 1943 for war training, and although most buildings, including the Manor House and Church are still standing and preserved, the residents were never allowed back. The road to it, several miles over Salisbury Plain, was opened specially this week, with even a bus service and it was crowded with visitors. A fascinating experience.

Summer’s not over yet though, so please join us if you can at The Barge at Seend for our friendly meets, on the last Monday of every month. Whether your Spridget is in action or not, help and advice is freely available, along with bad jokes and gossip, and many more chances yet to get the wind in your hair!

**Andy Cross**



# A TRIP DOWN MEMORY LANE



At the end of a Central club visit to The British Motor Museum at Gaydon ( Mascot July 2019 ), we were gathered and ready to make our departure, when a very nice lady leaving her offices at the museum stopped to look at the cars. She mentioned in passing “If you had given me 2 weeks notice I could have arranged for you to visit the archive centre, to see all the individual production details of your cars”. If only we had known!

At our next meeting, still in my head, I suggested to Dave Warren that we should perhaps do this. Dave agreed and contacted the BMM later that week and a date was set.

We met in a pub car park (where else) on what turned out to be the second day of a major European heatwave! So short sleeved, top down, lathered in Ambre Solaire (double layer on the right arm for cruising), our MG Midget and Frogeye set off down the old A5 Watling Street and along the Fosse Way. On arrival we were shown to the archive room and the same very nice lady that we had spoken to some weeks earlier, checked us in.

We were seated at a computer terminal and shown how use our car information, such as chassis number, engine number to access our car files, then left to our own devices, Dave went first. After much screen scrolling and note taking “I didn’t know that Rostyle Wheels had been on my MG from new”,he said.

Lots more screen scrolling and notes later Dave had what he wanted. I punched in the Chassis number of my car and copies of hand written production records of my Sprite, written by men in brown engineering coats, started to appear. Abbreviations written in pencil in the card margins, such as WW, LPC,RC.What were these?Consulting the oracle sitting behind the glass fronted counter, these were explained as the optional extras added to the car, in

this case Window Washers, Locking Petrol Cap and Rev Counter. You even had to specify a heater if you wanted one !

I found that my car came off the body and the trim lines on the 11th June 1959, and out of rectification and finishing on the 12th June 1959. My car was already 60 years old. It was despatched and invoiced to the dealer, Carlaw Cars Ltd in Glasgow 31st July 1959, and then first registered 5th September 1959 with the plate XGG 872.

Later with information and refreshments in hand, we sat in a shaded spot of a nearby hotel and recalled a truly memorable day.

I purchased my Sprite December 2018. In the months since, I have visited car events all over and in all weathers. Taken part in several club event days, from Drive It day to meeting up with the Nott’s / Derby Club at Matlock for Fish & Chips, or driving down to the new Northants Club 3rd meeting at Thornby only last week.

I became a member of MASC in January 2019, and my Westminster Blue Frog Eye has even made front cover of MASCOT, July 2019. This time on a fabulous visit to Rutland Water organised by Dave Sewell, another Central enthusiast.

It is fair to say that this Frog Eye Sprite of mine has opened up a whole new world and I am enjoying every minute of it.

## Gary Morris –Central member



# SILVERSTONE CLASSIC 2019



Every year I look forward to the Silverstone Classic, it brings members from across the country together, there are more cars to look at than any normal classic car show, there is great classic racing and the access to the cars and the pits amazes me. Those of you that remember last year's Silverstone Classic will no doubt remember the glorious weather, the track parade and the brilliant turn out of member's cars on the club stand. This year we had one out of those three to celebrate.

We had almost 30 cars booked in for each day of the weekend (F26,Sa30,Su29) which is brilliant and not that short of the numbers attending last year, but the weather was not so good. For me the classic is a 4 day weekend as we always setup the gazebo and think about how we will fit the cars in the spot allocated to us by the organisers on Thursday. Our location is determined by how many cars we have attending and this year we had a good central spot near the track, near the bus stops and near the trade areas. We also had plenty of space (not always the case!).

The setup on Thursday was a challenge though; a record breaking day, the hottest UK day on record in fact. However within three days the temperature had dipped by 20 degrees and it did get a little damp. However we all know that doesn't stop Spridget owners having a good time, although actually it did stop 1 or 2 arriving in their Spridgets and given the distance some travel I don't blame any of you.

There were some great cars on the stand, many were first timers and some were regulars. One of the highlights for me was Jonathan Whitehouse-Bird's deep pink mkII Sprite (sorry we didn't get to talk!). It was also good to see Steve Brook's RWA Midget make it of the campsite on Sunday morning having had a clutch bled numerous times by Stephen and his brother and nephew. It made it back to Westward Ho! too. We had lots of Frogeyes and a good mix of the other models too.

So despite the weather, which I think spiced up much of the racing, everybody seemed to have a good weekend. I do try and chat to all who members that come along for the weekend, but inevitably I never manage to – sorry if we didn't get to catch up. I am already looking forward to next year. If you have not been before please try it out next year. The club discount gets you and a friend plus your car into Silverstone for half the price of 2 daily entry tickets. If you are into old cars, interested in the racing or just like catching up with other owners this is the event for you. See you in July 2020?



# 5 IN A MIDGET



A report of clutch failure leading to a 5-speed gearbox conversion on my 1970 Midget. When the clutch failed it did so without warning accompanied by the noise of something metallic breaking!! At that point I was about 10 miles from home but with a bit of brute force and slight lack of mechanical sympathy I got home without the need of recovery.

Having tried to fix the problem of the clutch not disengaging by changing both master and slave cylinders without success, I never had much faith in changing them due to the fact it failed without warning and with a bang, but easy jobs first. Next job remove engine and gearbox, split the two and get them on the bench. That done I then removed the clutch assembly to find all the diaphragm fingers at different heights and angles. I had in the past removed the centre thrust pad to enable the fitting of a roller release bearing - had this

caused the problem? (maybe I should have fitted an Alan Anstead one). Also found broken was the inner spring steel ring attached to the 3 diaphragm springs and I am guessing this was the part I heard break. I have seen a few clutches in my time but never seen one of these break before. Just in case you are wondering it was a Borg and Beck unit.

Moving on, I have been considering for quite a while doing a 5 speed gearbox conversion and had kept my eyes and ears open for a Datsun unit, as it fits without major body alterations. Now my car was in pieces I thought this was the prime time to find one and carry out the conversion. So long story short, I was able to purchase one from within our club membership at Little British Sports Cars. As a bonus the unit was removed from a Frogeye so came with most parts needed for the conversion - engine backplate, flywheel machined



and drilled and tapped for Datsun clutch, propshaft, etc, etc. OK lets get started - remove standard flywheel and backplate, fit conversion backplate but problem it will not fit due to the fact in the past I had fitted the crank rear main oil seal conversion kit, the type available from Moss and others, so back on the internet and talking to more Spridget folk, I discovered there was another crank oil seal conversion from [www.calverst.com](http://www.calverst.com).

So after speaking to Keith at Calverst and removing the Moss kit I decided to fit this seal, full details on website, but just to say the fitting of the seal does involve engine parts machining. Another small but important part of the gearbox conversion that needs to be tailor-made is the spigot bush - I had one made from phosphorus bronze. I am pleased to say fitting the other conversion parts, and finding a new Datsun 3 piece clutch and slave cylinder was no problem.

Before fitting the engine and gearbox back in the car I decided to check the clutch operation and hydraulics on the bench. So with the aid of a basic pedal assembly I made to operate a master cylinder, I am pleased to say all was working fine. Looking at the web and forums for this conversion I found that sometimes there is a clearance problem between gearbox bell housing and battery tray area when installing engine and gearbox as one unit, so to try and avert any potential problems I installed the gearbox for a trial fit. As I had taken measurements before removing standard engine and gearbox, I was then able to use those measurements to set the height of the Datsun gearbox in the car, to find it was fouling on the heater trunking under the battery tray, so having thought about modifying the car or gearbox bell housing to make it fit and give clearance I decided to modify the gearbox with the view that it will now fit into any Spridget.

The work I did was cut a section from the top of the bell housing and replaced the removed section with a flat plate which I welded in so creating a flat area instead of rounded which enabled enough clearance.

After that modification reinstalling engine and gearbox back in the car did not present any problems - an added bonus in my opinion with this conversion is that the gear stick comes through the standard hole in the tunnel, although it does fit further to the left and as I was keen to keep the standard look inside the car I had to modify the metal gear stick cover. Another job to overcome is the speedo cable as the fitting is different on the Datsun box to the Midget one so a new tailor-made cable is required. Also to enable the cable to run in a nice gentle arch and to avoid cutting a hole in the tunnel I purchased an angle drive fitting both from [www.speedycables.com](http://www.speedycables.com).

I have now covered about 600 miles and pleased to say all is going well. There was a few trials and tribulations along the way but now it is done the car is even more of a pleasure to drive than it was before. I can now cruise at the legal motorway limit in 5th gear with a 3-9 diff and standard wheels/ tyres @ 4000 rpm.

**NOTE** For anyone interested or planning to do this conversion I have kept a detailed list of parts and suppliers used and would be pleased to pass them on along with some tips I have learnt along the way.

Keith Warner, HCNW  
[mrkwarner@hotmail.com](mailto:mrkwarner@hotmail.com)  
07800 875835.



# HAZARD WARNING FOR EARLY CARS: PART-2

Of all the after-market hazard warning options currently available, the 'Universal Hazard Light Switch' (part number 0-484-50 or 081901) is perhaps the only one that can operate both indicator and hazard lamps with a single electronic flasher unit and, at the same time, satisfy safely all four requirements for a proper hazard warning system<sup>1</sup>.

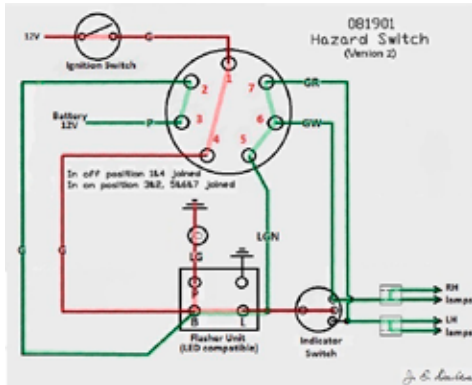

*Circuit diagram: Universal Hazard Switch. When the switch is OFF, the circuit highlighted red is active for indicators. When the switch is ON the circuit highlighted green is active for hazard warning.*

The stumbling block is that this ingenious 'Universal' switch is large: it requires a giant 30mm diameter hole and would look quite out of place in the kidney shaped dashboard of an early Sprite or Midget. If we want a small hazard switch, the hazard switching mechanism must be separated from the switch itself. Inevitably, this means we should start thinking about relays - but which relay (or relays) should we use?

When it is switched on, this 'Universal Switch' performs two quite different switching operations: it 'changes over' the 12V supply to the relay and it joins together the LH and RH sides of the indicator circuit. By itself, no standard 12V relay is able to perform both tasks but a 'changeover' relay<sup>2</sup> can perform the first and a 'twin contact' or 'twin output' relay<sup>3</sup> can perform the second.

1 See MASCOT August 2019 p 12-13

2 See MASCOT April 2019 p25-26

3 This special relay (cat no RY2504) can be purchased for £3-35 from Towzatronics (Tel: 0115-837-0245, Email: info@towzatronics.co.uk). When this relay is energised, pin 30 is connected simultaneously to TWO pins 87 and 87b.

## PART-2

If we join pin 85 of one relay to pin 85 of the other, and similarly for pins 86, then a single switch can operate both relays. This two-relay circuit is best understood by referring to the circuit diagram.

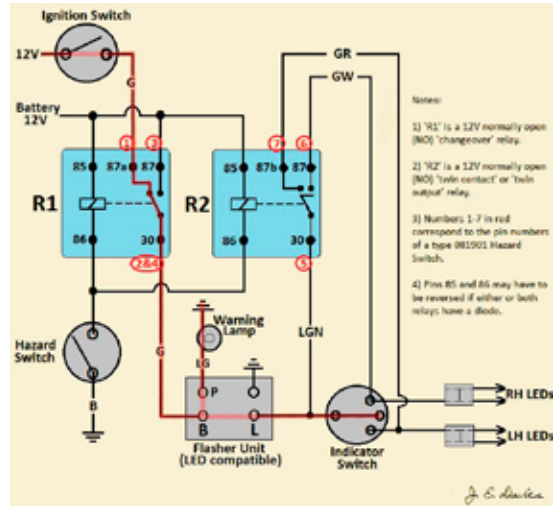

*Circuit diagram: two relays R1 and R2 can emulate the action of the 'Universal Hazard Switch'. Here the hazard switch is OFF and the circuit highlighted red is active for indicators.*

When the hazard switch is on, a small current (ca 150mA) flows through terminals 85 and 86 of each relay and both relays are energised. Inside relay R1, terminal 30 is disconnected from terminal 87a and connected instead to terminal 87, so switching the flasher unit's 12V supply from ignition-fed to battery-fed<sup>4</sup>. Inside relay R2, terminal 30 is connected to terminals 87 and 87b, so connecting the LH and RH flasher circuits to the output of the flasher unit. This precisely emulates the action of the Universal switch: the difference is that the two relay circuit allows the hazard switch to be tiny.

4 The fused supply to the horn at the fuse box is a convenient place to make this connection.

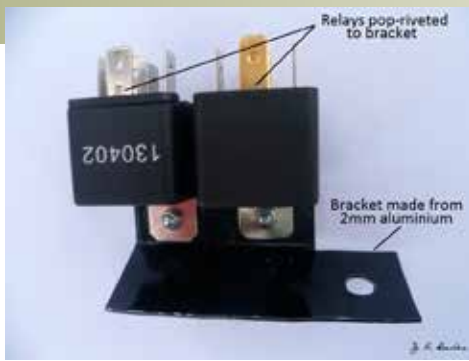

Here the relays R1 and R2 are attached to a simple bracket, ready for wiring at the bench.

Also note that, in contrast to the lamps in some aftermarket hazard kits, the hazard lamps in this relay circuit will operate correctly no matter the position of the ignition or direction indicator switches. The two relays may be placed in any convenient spot, I attached mine to a simple bracket snipped from 2mm aluminium sheet, then mounted the assembly under the bonnet, close to the flasher unit, using one of the set screws which secure the pedal box to the car. Other mounting solutions are possible, it's your choice.

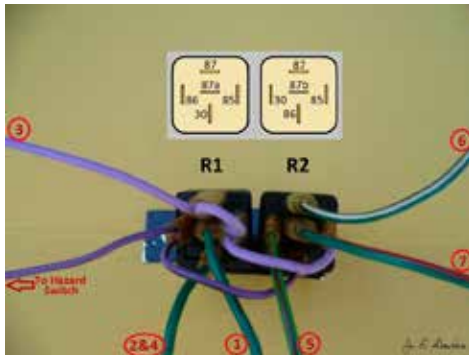

Here the two relays are wired up, ready for installation. Connection numbers (circled red) correspond to those in the circuit diagram. Note that relay terminals 30 and 86 are NOT in the same position on both relays and that terminal positions may vary on relays from different manufacturers

The 'GW' (green / white trace) wire, connection 6 in the circuit diagram, should be connected to the spare hole in the 4-way snap connector which joins 3 'GW' wires together. This snap connector is located either in the engine bay near the flasher unit (Frogeye Sprites) or high up in the RHS foot well panel, at the end of the dashboard (all other cars). The 'GR' (green / red trace) wire should be similarly connected to the spare hole in the 4-way snap connector joining three 'GR' wires.



Here the relay assembly is secured with one of the pedal box set screws (arrowed yellow). Note that the 'LGN' (LightGreen / Brown trace) wire should terminate with a piggyback connector (arrowed red) because it must be joined to the flasher unit's original LGN wire.

Where to place the hazard switch (and what sort of a switch it should be) is another personal choice. I chose the smallest latching (push on / push off) switch<sup>5</sup> I could find and installed it in the under-lip of my dashboard, beneath the ignition switch. Despite its tiny size this switch is rated 3A/125VAC, well able to cope with the 0.3A/12VDC demanded by this application. Even if obscured by a dangling ignition key fob, it is located easily by 'feel' and, because it is positioned in the middle of the dashboard, there is no danger of pushing it accidentally with one's knee. Concours judges may not approve but, as I have said before in this magazine, if it's a choice between originality and safety, I shall choose safety every time.



Installed in the under-lip of the dashboard of my GAN1 Midget, the small hazard warning switch is barely visible. On my GAN2 Midget this same style button is invisible, concealed behind the lower crash padding of the later style dashboard.

**John E. Davies (Member 3443)**  
jed2@cam.ac.uk

<sup>5</sup> Suitable switches are available from all major electronic suppliers. I used a Q-MAX sheet metal punch to create the necessary hole (12mm) and a right-angle attachment for my drill to make the pilot hole for the punch.

# FROM THE BOWELS OF BRISTOL



Earlier this year, I announced that I had written my final report for Mascot prior to Brexit. Still awaiting, I find that I must now retract this statement. Not only has our government kept us waiting, but then has the audacity to call upon some of us to do our duty, and to do it without delay – or else!

As good and loyal citizens, we do our bit by registering to vote, reporting for jury service, cheerfully paying all our many and varied taxes, but there is something else that few people realise that you can be called upon to do for your Queen and country.

Evidently, the members of long established and respected organisations, such as MASC, can be called upon under the auspices of 'The People's Inspectorate of Government Services', or in short – PIGS. And so it fell to the members of MASC Bristol and MASC Wiltshire, we received the Pigging order. Our mission, to visit an MOD establishment whilst normal members of the public had gained free access and to report back on the security issues arising from such a breach.

Our mission date of 18th August was preceded with much planning. As an army establishment would be our target, we had to tackle this with a military mind and with military precision. Mike Davis is the closest member we have to a Field Marshall, who then selected Roger Stratton as his Bat Man, the closest member we have to a Bat. Well, someone said he slept upside down. It followed on that we then needed a 'Robin', at which point, we realised

that we had lost the plot and needed a Colonel instead. The rest of us fought over the lesser ranks, whilst I just defended my Privates.

Our target was to be the requisitioned village of Imber on Salisbury Plain. The MOD had expelled the inhabitants in 1943 with the promise to return their village once they had done with it. However, just like Brexit, they failed to deliver on their promise. To this day, Imber is closed off to the public, excepting for rare and special occasions, August 18th would be one such occasion. How would the public react? It was our Pigging mission to infiltrate and to report back.

Six units from the Bristol Battalion took a meandering route to Malborough to form a Pinzer movement with a further 12 units from the Wiltshire Regiment. Here, we reported to Andy 'Military' Cross. Following a final briefing, all 18 units departed for Imber along some truly stunning and strategically selected roads. As we approached our target, two units laid down a smoke screen, worn valve guides and piston rings were chiefly responsible for that,





to give us the element of surprise. However, most of the surprise was ours, all 18 units had arrived without any losses (other than a few pints of oil).

We cunningly parked up in the bushes then advanced on foot to the village itself.

Our presence went unnoticed as we mingled with the public who were there by the hundreds. The village is miles off the main roads, deep into MOD property with many notices that don't say 'Welcome' or to 'Please roam freely'. Indeed, trespassers are not even threatened with prosecution, death by explosion being far more likely than an appearance in court. The Army use this area as their training grounds, Imber being slap bang in the centre of all the action. Once a year, the public are allowed in to visit this long lost village.

Only the Church, St Giles, remains intact and useable, all other buildings being little more than derelict shells with modern steel roof panels. The Army have built more modern buildings for training purposes but these were off limits even to us pigs.

It was sad to see the remains of a once close knit community reduced to what it is today. One can

imagine what life must have been like and the reaction to being told to leave their homes, the promise of a timely return that was never honoured, sad.

I would have liked to report further but as our mission was a pigging operation, then our findings are Government classified and not for your eyes. However, I can reveal that the greatest threat to life came not from unexploded ordnance, but from the Portaloos, Although, had we not retreated for a pub lunch, we may have witnessed one of these exploding with the amount of gas that was building up.

Following a successful withdrawal, we debriefed at the Churchill Arms, our leadership having booked a secure operations room. Here, the intelligence gathered on our mission was encoded and sent on its pigging way followed by a jolly good cavery.

Our government have to thank, and who knows, possibly decorate, Mike Davis, Roger Stratton and Andy 'Military' Cross for planning and carrying out a highly successful mission on behalf of the nation and in particular, the pigging members of MASC Bristol and Wiltshire.

Standard sign off – And a good day was had by all.  
**Corporal Terry Horler (retd)**





The world's leading  
Austin Healey  
parts supplier!



[www.ahead4healeys.co.uk](http://www.ahead4healeys.co.uk)

Tel: 0044 (0)1788 565 000

Fax: 0044 (0)1788 565 001

[info@ahead4healeys.co.uk](mailto:info@ahead4healeys.co.uk)



81 Somers Rd, Rugby, Warwickshire, CV22 7DG, UK

*Mike Authers Classics*  
Specialist in Chrome bumper MG Midgets and Sprites.



**WANTED URGENTLY  
MIDGETS AND SPRITES**

Excellent prices paid for Frogeyes, Original or  
IOW  
In any condition



Up to £8,000 paid for Midgets  
and £17,000 for Sprites

Tel Mike on 07703 465224

Or [mike@mgmidgets.com](mailto:mike@mgmidgets.com)

## Insurance tailored around you and your classic car

At Adrian Flux we have over 40 years experience tailoring insurance to suit your specific needs. We don't believe in "one size fits all" when it comes to insurance, which is why you could save time and money by calling a member of our team directly on **0800 916 1288** compared to online.



Ask our experienced  
staff about:

- Club member discounts
- Agreed valuations
- Limited mileage discounts
- European breakdown cover
- Driving other vehicles

**Car Club Quoteline: 0800 916 1288**

Mon-Thu 9am-9pm, Fri 9am-7pm Sat 9am-4pm. Authorised & regulated by the Financial Conduct Authority

[adrianflux.co.uk](http://adrianflux.co.uk)

**ADRIAN FLUX**



Kimbolton Castle Classic Fayre was attended by ten of our special cars alongside dozens of other car clubs at this popular event and it was a first for our club shelter (the instructions did not mention that seven men with a female supervisor -Jo -was necessary to erect it, see photo).

This event has something for everyone, from mediaeval battle enactment, dog and horse displays and finally a publicly voted car of the show all in the central arena and a midday low flypast by a WW2 hurricane.

We arrived at the Silverstone Classic on Friday practice day and lined up with the other ten spridgets on the allocated club area to enjoy a less crowded days racing. Upon returning to the club for lunch and then later to head home, we were the only car remaining, a shame as we had hoped to meet a few members as in previous years.

On the way home we had to adopt the Terry Horler recommended speed of 47.6 mph to avoid getting a wet neck in the rain.

On August 4th the Higham Ferrers event was poorly supported by our area although it was apparently as good as in previous years.

The most spectacular event of the year has to be our visit to Classic Team Lotus at Hethel in Norfolk, we were invited by Lotus employee Steve, after

meeting him at Earsham Hall classic event earlier in the season.

This ultra modern building houses some of the most iconic lotus racing cars that we have either seen performing on the track or recorded on film and all still owned by the Chapman family.



Amongst the archives Steve showed us an original design drawing on tracing paper of a Lotus seven in elevation, moving into the workshop we saw classics in various stages of repair/refurbishment in totally clinical work bays, absolutely spotless – Maggie was impressed – but I do not think it means I can work on the frog engine in the kitchen.

Momentous photo's adorned the walls, where there was space, alongside Lotus models used for wind tunnel testing, but the ultimate was the array of a least 50 classic racing machines several privately owned.

There really was so much to report and take in that to do it justice one would have to go back and join in an official tour (cost £45) something I certainly intend doing again.

## Events:

**Capel Manor Gardens Enfield Classic and Vintage Car Show** Sunday Sept 8 10:00- 5:30pm  
Nigel +Diane recommended and will meet at Trumpington P&R 08:30 for 1hr trip

**British Motor Museum** Gaydon Warwickshire  
Sunday October 22 Info:classicworld.co.uk/  
subscribers-day or tel 01959 543 747 - club  
convoy details tba

## Graham Jenkinson Kirkup

PS. Many of our area members are having area rep messages sent to their spam a/c thus unaware of club messages, will try to get this sorted although the system should already cope. CAMBRIDGESHIRE





*Maxine and Alan Sleigh with their Sprite at the Canwell Show.*



*Paul Beardmore, right, with Andrew Parrott, left, pictured at Matlock.*



*Elaine Parkes drives her Sprite around the show ring at the Canwell show.*

The weather has played a major part in Central events during the last few weeks.

A Sunday meeting at Newhall Water Mill near Sutton Coldfield was the first warning of what was to come. Only three of the six cars hoping to attend the event arrived in torrential rain. It was on with waterproofs, sturdy boots and wide brimmed hats. The weather didn't improve all day as we huddled under shelters or took refuge in the busy cafe. To make matters worse, someone had slid back the side window of Gary Morris' Sprite to take a look inside but had not closed it. When he came to drive off the interior was soaked due to the strong winds blowing in the rain. At least we all managed to drive home safely and hang up our carpets to dry out for the next outing.

Waterproofs were definitely not needed for our drive to Matlock to meet up with the Notts / Derby group

on a balmy Thursday evening. Meeting at the Tame Otter late afternoon I was met with members in T shirts, shorts and holding drinks laden with ice cubes. Among those joining us was Paul Beardmore who leads a very busy life but had decided this was one event he really had to go to. Andrew Parrott had also decided it was worth making the trip up all the way from Northampton. As arranged we took the road to Abbotts Bromley collecting Jean and Denis Grimes on the way. Arriving in Matlock in warm sunshine we joined our fellow MASC members for fish and chips outside before a small drive to finish the evening at a local pub.

One wet event, one dry, so, no surprise the next event had both. The Owen Motor Club had kindly invited us to the Canwell Show. The day started hood down in sunshine, however as we arrived a blustery wind, the showers had us unfolding and raising our hoods. Maxine and Alan Sleigh had decided to sit in their car whilst it was raining. It was then I noticed the rain had turned to sunshine and Alan had fallen asleep. He was only awoken by someone wanting to take a picture of their car. At least he could now enjoy the rest of their day in brilliant sunshine. Also attending the event was Elaine Parkes in her Sprite. A call was made for cars to take part in a parade in the show ring and Elaine was soon steering with one hand and waving to the crowds with the other. What better way to end the event than by showing off one of our lovely cars to smiling people eating ice creams and enjoying the summer.... did I say summer.... weather.

**Dave Warren**

Central MASC

Email to [central.masc@live.com](mailto:central.masc@live.com)



1st June – Torbay Air Show - 2 cars attended the show. Tom & Kristina in their Red Mk2 Sprite which he has owned since new and Chris & Bob in Chris's Riviera Blue Mk3 Sprite. We were able to have a very good place to watch the air show from the Palace Hotel Paignton, where we had lunch and a few refreshing drinks as we watched the Red Arrows perform their aerobatics, never failing to impress.



12th July – Powderham Castle Steam Fair - unfortunately on the day we were setting up our Coleman Shelter I fell down a flight of concrete steps and fractured my wrist so was unable to assist in the setting up, fortunately we had plenty of helpers. The 3-day show was a great success as we had the Dorset Area supporting us and bringing 3 cars to the show. Poor John Gully was unable to attend as he had badly damaged his hand. Those from Dorset who did attend were Ian & Chris Beaver Mk3 Midget, Dave Stebbing 1964 Mk3 Sprite & Lawrence Pine in his Mk3 1970 Midget. Devon members were Tom & Kristina Shell Mk2 Sprite, Barrie & Dianne Smith Mk3 Midget, Mark Cairns



Mk4 Midget, Mike Ellis Mk4 Midget, Colin Lennon-Jones Replica Sebring Sprite, a great 2 days were enjoyed especially as there were about 1500 classic cars on display with an added hog roast, Cornish Oggy tent and a very large beer tent, what more would you want with a classic car show? Good weather? We had that as well!

4th August – We had a good turn out for Torbay Steam Fair, altogether 7 cars on three days and also supported by 2 cars from Dorset area. The weather just about held off, some very light showers, but that didn't dampen our spirits, it was an excellent show that everyone enjoyed. Thank you again Dorset for supporting us.

**Chris Wood 5130**





Through the good offices and work of David Clarkson and Chris Wood in Devon Area, four of our Dorset cars were due to join Devon on their stand at the Historic Vehicle Gathering at Powderham Castle in July.

In the event only three cars supported, as a couple of days before the event I managed to damage my fingers in an incident with a door! Much to my shock I then learned that Chris had also had an accident and was on crutches.

But the three who attended enjoyed their time with Devon and I'm only sorry I missed a good day. Chris, I hope you are mended now.

The Poole Bay Classics annual motoring Extravaganza saw eight of our cars supporting and the first erection in anger of our MASC gazebo – and very good it is too. This event has clashed dates with a huge nearby show and the organisers have now rescheduled for next year which should eliminate the diluted attendance of the past couple of years.

The day after the Extravaganza on club night we had our PDQ (yes - it stands for what you think!) road run, organised by last year's winners Chris and Ian Beaver, and this year won by Sarah and Adam Price. They now have the honour off organising next year's run!

Later that week a few members, together with friends, had the opportunity to visit what is one of only two jigsaw factories in England. Jhguzzles manufacture over 200,000 puzzles annually. We saw the whole production process from raw materials, through gluing, box assembly, cutting the pieces and packing and wrapping. Some of the machinery is from the Sprite/Midget period and was fascinating to see in operation.

After helping pack some jigsaws we sat down to a well earned excellent afternoon tea and plentiful cakes! Thanks to Terry Mobley for organising this visit and to Julie and Brian for showing us around.

Visiting a car show at Lymington and invited in my Frogeye 'Vera' on to the AH Club New Forest Centre stand, I was interested to see four other Frogeyes there including a race car which, according to a placard with the car, had been timed at over 140mph! at Silverstone. A good day and nice to see more restored Frogeyes emerging into the daylight.

The Bournemouth and Poole MG Owners Club held their annual picnic at the attractive Athelhampton House and we had a good turnout for that as usual. But one thing that strikes me is that we are seeing the same small group of MASC members supporting local events and we would welcome meeting others whom we know are in the area and to see their cars.

September 15 sees a new departure for Dorset Area, a short road run followed by lunch at a pub on a Sunday morning. All Midget and Sprite owners are very welcome to join in, just get in touch.

Happy motoring on clear roads ...  
John Gully, Dorset Area Representative



**POOLE BAY EXTRAVAGANZA**



**PDQ RUN WINNERS SARAH AND ADAM WITH IAN**



**AFTERNOON TEA AND CAKES ON JIGSAW FACTORY VISIT**



**RACE SPRITE AT LYMINGTON**



**AREA LINE-UP AT MGOC ATHELHAMPTON**

*Rumoured to  
be Gary's new  
holiday pad*



## Long live the Summer

Our midweek run in July was organised by Colin & Elaine. Having had a number of problems with roadworks on their previous run, causing cars to disappear off in all directions on various detours, some never to be seen again. Following a huge amount of ribbing, planning was meticulous this year with a dry run the weekend before to make sure that the route was clear.

Everything started off as planned, unusually for Colin, not known for his time keeping we departed exactly on time, with all members accounted for. Starting with a very interesting trip around some of the more obscure lanes of the town of Maldon followed by an hour's drive through the rural countryside of the Dengie peninsular. We were 55 minutes into the journey and all was fine, great planning this year we all thought, then disaster struck. Only 100 metres from our destination and with the pub clearly in sight, you guessed it, an impromptu road closure and a 7-8-mile detour. We finally arrived for our pre ordered meals to be served almost as we sat down. More ribbing for Colin about his organisational skills and the mention

of a possible new trophy with his name on it for presentation at the Christmas dinner!!

Owen and Lucy were joined by six other spridgits for their Sunday run. The weather was very pleasant and the route took the group through areas of Essex rarely frequented venturing deep into Epping district or 'TOWIE' land for those of you familiar with the TV series, where the roads are lined with huge gated mansions and home to ladies who wear white stilettos and who are rumoured to dance around their handbags.

Sadly Tim & Linda and Di and I missed Owen's run as we had taken our Frogs to France on a 1,500 mile trip to La Rochelle, the return route along the beautiful Loire Valley being particularly delightful. We all loved the trip and the cars behaved impeccably.

As the summer months continue, there are two runs planned for August. A mid-week pub run on 6th and Sunday run on 16th everyone welcome particularly those members of the Essex branch who have not ventured out with us before.

**Gary**



The club met as usual at the Green Dragon where most of the members attended in their Midgets and Sprites as it was a lovely sunny evening. Attendance was a healthy 30 people which included Peter and Victoria Good who were

attending for the first time. Welcome to them. It was a quieter month with the main highlight being the Worcestershire Wanderings which Stuart and Sybil organised.

## Worcestershire Wanderings

Saturday 13th July saw a group of 10 cars on the Worcestershire Wanderings – more a run of multiple refreshment stops interspersed with bouts of driving starting with coffee at the Witley Court Tea Garden through the beautiful Teme Valley with a brief dip into Herefordshire for lunch at Ralph Court Gardens, tea and cakes at Roger and Sue Orgill's in Malvern and finally lazing by the river at the Anchor Inn, Wyre Piddle. Thanks to Sue and Roger for the scrumptious tea stop. By chance a keen photographer was there at Witley Court to record us on film in a much more professional way

Photo Bill Kelly



than our smartphones. We did well to stand still while he took the panorama shot – memories of school photos but no-one appeared twice. Thanks to Bill Kelly [billkelly@blueyonder.co.uk](mailto:billkelly@blueyonder.co.uk) who was just visiting from Liverpool.

**Stuart & Sybil.**

## Coming up

We are looking forward to our weekend away in August exploring the villages used in the Midsomer Murders dramas, lets hope we all get back in one piece.

1st Sept sees the revival of the Coventry run now called "Not the Donkey Derby", Should be a good one.

Report next month.

**Dave & Linda**



**Robin Lawton**

VINTAGE & CLASSIC CAR SPECIALISTS

QUALITY SPRITES  
AND MIDGETS  
ALWAYS WANTED  
ESPECIALLY FROGEYE  
AND PRE-74 CARS

We specialise in selling quality Vintage & Classic Motor Cars and Spridgets have always been a particular passion.

We are located between Peterfield and Alton in Hampshire, between the A3 & A32 in the beautiful South Downs National Park.



WE OFFER - OUTRIGHT PURCHASE  
OR SALE ON COMMISSION

T: 01420 474919 [WWW.ROBINLAWTON.COM](http://WWW.ROBINLAWTON.COM)





High temperatures followed by monsoon rain. Global warming? No, just typical British summertime. Luckily most, not all, took no note of the weather forecasts and turned up for the monthly meet, at Angel P.H., Addington Green in Spridgets: except for Darren who came in his self built E-type Jaguar sports racer.

Celebrating our fifty years together I exercised my Frogeye (1959 - 1969) that Alan Pritchett has kindly asked me to display on the Masc stand at NEC this coming November subject to completion of, and return from, a solo tour in France between then and now.

Like me it seems that Spridgets do not like the hot weather: or do they just like to stop their respective owners enjoying a nice drive on a warm day. Several Kent cars have been off the road this month with a variety of problems such as cylinder head; a bent pushrod; a change of overdrive, suspension problems and a not unusual call for one of my 1275 roller release bearings to replace a short lived carbon type.

A type 9 Ford 5 speed gearbox has changed hands between members so swiftly that my hands had barely lifted from the keyboard when circulating that it was for sale. Will this be an over-winter project in advance of continental travel next year? Perhaps another visitor to 10th Le-Mans Classic over the weekend of 3-5 July 2020.

Not so sought after but another Kent member Martin Bird has a smooth-case gearbox, left over from a type 9 conversion that I performed on his Frogeye some years back now, for sale if any purists out there want one. Martin feels that the time has come to sell his Frogeye. It is dark red with, as aforesaid, a T9 5spd gearbox and a 1098 engine. I understand he is looking for offers circa £6k. Details can be forwarded.

We welcomed members from other areas: Tom Taylor from Sussex came in his IOW Frogeye: he was eyeing a different return route to avoid traffic around Tunbridge Wells. He is nursing a loose carbon in his clutch release: I await his phone call!

Mark & Caroline Jackson brought their Midget from the other side of Surrey, but I believe the highest mileage by a non-Kent member was achieved by Surrey's John Gibbons who drove, was it 180 miles, on a round trip to just pay us a visit?

Just a suggestion: if anyone from a surrounding, or not too distant, county is looking for some where to go for a drive out on a Sunday, for their group, you could join us for lunch at The Angel which has several motorway, main road, minor road links.

**Alan Anstead. Kent Rep  
01322-384050 (answer-phone).**

## And from John Clark..... It's Hot in East Kent

We really were in Summer mode in East Kent this month and even delaying our monthly meeting at Sarre by a week did not deter the sun god. Typically as it is summer, half the roads around here have been shut for repairs. Weekend closures of the M2 motorway did nothing to aid travel east-west across Kent indeed only four Spridgets made it this time but all were topless. Such was the spectacle that even a passing E type stopped by to check us out.

I keep a register of attendances for our annual competition to judge commitment and bonus marks are added if hoods are stowed. It is coming to something when our Phil who shall be nameless marked his car as absent (in the workshop with bonnet up and head off) but hood down just to gain his mark. With all cars present working well all time was devoted to the serious business of eating with conversation working towards a Tour destination next year.

The previous Sunday we were invited to a BBQ in the garden of Bryan and Sharon near Faversham and very splendid it was too. Their garden could be Kent equivalent to Kew. The main problem though was the Motorway closure again and the fact





that The British Grand Prix was on as was World Cup Cricket, The Tour de France, and the start of the World Cup Netball. Despite all this a goodly collection of cars turned up with others out of shot.

TV s around the house kept us up to date with the sport with our cars visible from the F1 viewing lounge window. So with Lewis winning and England cricket on a high everything in the garden was really rosy.

Another social event was our invitation to attend the Kings School Week event on their playing fields. We picked the hottest day of the year so spent most of the day seeking shade whilst our treasures melted on the velvet like grass alongside the other invited marque, the local Rolls Royce Club. Well we were up against amongst others the sister car to the yellow version as seen in "Goldfinger" both cars originally owned by a single family.

Suffice to say it was quite a do with Junior Show Jumping behind us, two cricket matches stretching into the distance to the front, and tennis and touch rugby for variety. An added attraction, a carriage and two giving rides with proceeds to Riding for the Disabled.

A prize was on offer, a bottle of champagne from the School for the car most liked by the Headmasters Wife and despite his initial comments this went to our very own Derek Harris for his recently restored Frogeye. Personally I reckon his legs came into the equation but well done Derek. Needless to say it was not opened there and then and we were not doused in the bubbles. He took it home.

## East Kent Meeting at Sarre on 11th August

It's that time of year when attendance is a bit down when unimportant things like holidays, christenings etc get in the way but that said 14 souls with 4 real cars made it. One comment in the diary "nothing else to do on a Sunday so we turn up here" makes you think though but they (who shall not be named) are dedicated members and turn up every time. I can take it.

A return of a long time no see member Martin Bird with his cherry red Frog was very welcome. He was proudly showing off a classic Les Leston wooden steering wheel that he had refurbished and very smart it was too. Should look very nice on the car but first he had to produce a satisfactory pencil connector for the electrics. I well remember an incident when my horn sounded every time I deviated from straight ahead!

Depending on where you were seated conversation either revolved around gardening or at this time more important matters involving cylinder heads, 5 speed gearbox conversions and to aid the latter the purchase of a 2 post lift.

My nose to floor meeting to repair my failed clutch slave in previous days suggested that I can't work with just 18 inches of headroom for much longer.

Today's meet coincided with my Wife Caroles birthday so a cake hastily acquired the previous day (not from the local filling station) filled the bill and was suitably decorated. The number of candles represented a percentage of her years and in the words of our ever joking host made it easier to blow out and didn't affect his fire insurance. Somehow a cake said to provide 28 portions was devoured by half that number.

To end our Sunday meet some of us made our way to Fordwich outside Canterbury to an outdoor model rail live steam show with traction engines as well. Strangely as we parked our classics by the track to watch the trains go by we attracted a small crowd. We might go there again next year to aid their cause.

Planned events, another visit to the local classic bus collection, a mid week visit to a commercial vehicle MoT test centre and a possible show day at the Kent and East Sussex Railway alongside the Austin Counties Car Club.

**John Clark 3583 East Kent Coordinator**



For our second monthly meeting we had 12 cars, 15 people and a dog! We did a grand job of parking as haphazardly as possible blocking in the good natured pub regulars and other MASCeteers alike.

Two of the newbies had been invited by other members whilst others found out via MASCOT. Central's king pin Dave Warren also kindly joined us from Tamworth along with Keith Jewkes, another Central regular, making the trip from Coventry.

Simon, The Red Lion's young landlord, is keen to accommodate our needs so there may be scope for other kinds of events in the future. This time everyone seemed happy to spend the evening in the car park discussing our cars and why they are the way they are.

The VSCC cars meet at The Red Lion, Thornby every Thursday and they set off before it got too dark. We were roped in to push start a JAP-engined Morgan three wheeler which spluttered into life and then chugged off down the A5199 towards Northampton.

Any gathering of Spridgets reinforces to me what a broad church MASC is; from basket cases and barn finds to concours beauties, from daily drivers to track day weapons all are welcome with good advice and gentle banter exchanged at any and every opportunity. Each car is as individual as its owner and, perhaps unlike more exotic machinery, there are few cars that have not been modified in one way or another.

Meanwhile, at home, it was time for Mungo Midget's inspection in lieu of a 'proper' MOT. With the car up on the ramp at Sound Furlong Services it was good to get an opportunity to get underneath and have a good poke about. The continuous rust protection strategy I currently have in place is still working well but maybe I should look to sorting out the oil leak at the back of the engine at some point. It's bound to be the rear main seal which will require the engine and gearbox to come out. There are a number of other issues that I'm keeping my eye on at the moment but I intend to carry on using the car as much as possible for the time being. The cylinder head is coming off over the winter as a compression test indicated a problem; hopefully it is valve rather than piston related.

Mungo was rebuilt on a US shell in 1994 with new Heritage front wings being fitted at the same time. It has only recently been pointed out to me that these wings don't match – one is for an earlier car - something which I had not noticed and now cannot fail to spot. Considering that the car has been like this for 25 years I don't think I will win any awards for being observant! However, I spotted two other cars with a similar 'feature' at the recent Notts & Derby Fish and Chip event so it's not just me.





Classic Car Show, we had not been there before but it was set in lovely surroundings with Holker Hall standing amongst the beautiful gardens it is so famous for .

We had 6 cars go to this event, with 5 cars so therefore there were 10 of us, (Les had to return home that day,) staying at the Sun Inn in Ulverston for the Sunday night . On Monday morning after a late breakfast we made our way to the Laurel & Hardy Museum which is packed with memorabilia from their life times involved with the cinema. Their movies were showing every 20 minutes I had no idea that they had made so many !!!!

On leaving there we set off on a run along the coast road overlooking Morecambe Bay and on to Rampside where we parked up for a photo with Piel Castle in the back ground a place with fond memories of my youth I spent meany a happy time in my sailing days making my way over to the Pub which was still open when all the others in Barrow had shut !!! Happy Days ! the only thing on Piel Island is the Pub with then great beer for which I had some very good memories of !!! Then on to Coniston Water this involved driving along some amazing roads with the tops down all day and finishing up with a late lunch at the Black Bull in the centre of Coniston. The great thing about being a member of a club like the Midget & Sprite Club is the lovely people you meet, the fantastic roads we travel along not to mention the wonderful eating places we find on route.!!!!

Oakamoor Hill Climb. This I have to recommend as an event not to be missed On the 13th July, we had 9 cars travel to Stock -on -Trent and had a great day with cars of all ages soaring up one of the steepest hills, which was set in the centre of this lovely village. It seemed that all health and safety rules had gone out of the window Hooray !!!! and everybody loved it !! We all had a great day and will certainly return next year.

Sunday 14th July was another very good turnout for our Cars & Coffee meeting, Shelley made some home made cup cakes and Flap Jacks. Thank you for all your generous donations and She might do the same this month !!! This Sunday we added a slight twist to our normal meeting by having at the end of the morning a run to the Anderton Boat lift. We followed a route of about 48 miles devised by a friend of the club, Chris Lee. Motoring on a further 10 miles brought us to the Blue Cap Pub for a welcome late lunch and a lemonade.!!!!

Carrying on to the 20th July we were off again this time heading North to Cumbria for the Holker Hall

Shelley now wants to take over at this point to introduce our Ladies Section of the North West Midget and Sprite Club. I am very proud of the support these Ladies give to their Husbands and Partners and in doing so have all become good friends themselves. This means of course that our menfolk have very little resistance when it comes to attending various car shows, trips to different car events, weekends away and various car runs acting as very skilful navigators to boot !! Our Ladies have also been known to provide many varied and delicious picnics and encouragement when their husbands / Partners "Pride and Joy (classic car !!) have come to a sudden stop ending up with a view of said "Other Half " head down and rear end up cursing over the engine which had suddenly decided it was not very well and needed attention !!!!!!!!!!

## And over to Shelley.....

On our Lancashire Lanes Run a few weeks ago we decided that as we hadn't seen one of our Ladies named Sonia very often lately, mainly because Sonia's lovely husband Lee has this annoying habit of disappearing around the world on business and so is often not able to attend our monthly meetings Ahhhhhhh!!!!!! And As Sonia works part time in this wonderful Vintage cafe in Helsby Cheshire Val and I thought it was about time we gave her a visit !!! So having organised our "Other Halves " to give us a lift to the cafe after which they would be allowed to go on to view a boat museum in Elsmere Port and then come and collect us again !!! We all had a wonderful time at "The Banks Cafe" the afternoon teas resplendent on those lovely 3 tier cake stands, China tea cups plates and lovely matching cutlery was admired by us all. Obviously even more important than that were the delicate 'No Crust ' sandwiches, delicious light scones with jam and fresh cream, and a beautiful array of little cakes that melted in the mouth. The Waitresses were very attentive and our every wish was attended to so what more could we ask for. Helen decided on a Cheese and onion Tart and salad and I chose some delicious fruit loaf.



Apart from the lovely food the shop also sold beautiful young childrens clothes, and all manor of delightful ideas for presents for Family and Friends or for yourself !!!! A few of us succumbed to presents for "The Grand Children "!!!! Finally and



somewhat reluctantly we left the cafe and walked literally two minutes into our friend Sonias lovely home. Out came two bottles of Prosecco which seemed to go down very well. However at this point we decided perhaps Tea or Coffee might be the order of the day as we didnt want to appear drunk and disorderly when our Chauffeurs came to take us home!!!! At this point I must thank The Staff at the Banks Cafe at Helsby Cheshire ( Please do visit this lovely place of refreshment I am sure you will not be disappointed ) We all enjoyed a wonderful lunch or early Afternoon Tea and a few photographs were taken to mark this momentous occasion

This has been our first Ladies Outing from The North West Midget and Sprite Club adventure and I hope that it certainly will not be our last !!! I am looking forward to writing Episode Two in the very near Future!!!!

THE END

From Lynne,  
Val, Pauline  
.Karen,  
Heather  
Helen Shelley





Our current base at The Hunters Arms in Kilburn was the starting point for the July meet.

The uncertainty over the weather didn't put members off and 10 cars turned up with tops down ready for an early start.

We navigated our way between Derby and Nottingham city suburbs on a well proven route through the countryside, avoiding major roads where possible, until we reached Swarkestone Bridge and the River Trent.

The small village of Ingleby just along the Trent valley provides a picturesque setting for the John Thompson Inn and micro-brewery. It's large car park has ample space for our cars and Richard Sands and his daughter were already waiting for us with their frogeye in pole position.

A small sample of their own brew was inevitable to help the banter flow freely amongst members.

Naunton Classic and Vintage Transport Show and Fair and catch up on socialising with fellow car enthusiasts.

We had discovered this event two years previously. In this beautiful setting in the Cotswold hills overlooking the River Windrush, the village cricket pitch plays host to an interesting variety of over 150 classic vehicles. Together with cream teas and real ales it makes a quintessentially English day out.

The organisers always strive to show some rare and interesting cars and this year on display there was an Audi R8 LMX, a Suzuki Whizzkidd SC100, a Vauxhall from their Heritage Collection plus a one-off Triumph Stag Fastback. Previously we had been the only Sprites there, but this year there were a few more Spridgets in attendance.

The presence of a large number of Triumph Stags in the Owners



Club in support of the Fastback gives me the idea of a MASC meeting at Naunton in two years time if anyone is interested in making a weekend of it?

**Ian Cooke**  
Notts and Derby area coordinator  
ilcooke@btinternet.com

A few days later Alan Lodge and myself set off down the Fosse Way for a Cotswolds weekend of camping with friends from The Healey club. "Proper Healeys as opposed to Austin-Healeys" says John. The main reason being to attend the bi-annual





Well I don't know about elsewhere in the country, but the weather in the west of Scotland has been pretty poor with either consistent or infrequent but torrential cloudbursts. It has hardly been conducive with building the new garage, but some progression has been made, the walls and roof are now on, so at least it is watertight. It has been slow work, fitting panels around the doors, measuring and marking, cutting, then fitting them back up, but we are nearly there and I can start filling it with some cars. I am heading to Pickering on Saturday to attend Matthewsons auction and hopefully be successful in bidding for an Austin 7. Matthewsons feature in the television programme Bangers for Cash so even if I come away empty handed I should have had a good day anyway. Auctions are always fun, provided you are careful.

I was having a poke around the Good Frog and noticed a constant drip of petrol from the base of one of the carburettors, so off they came and I replaced the thick rubber grommet/washers at the



base of the float chambers and it seems to have worked. I am not sure whether it was just down to old age or modern fuel but I am glad I spotted it before it turned into a more serious issue, and also as myself and a few other club members will be attending the Boness Hillclimb it could have turned into a non event for me. We attended this event last year and had a good day so it looks like it is an established event on the Scottish area calendar.

**Graham**

# AREA REPORT YORKSHIRE

Our August meeting was held at The Drovers Arms at Skipwith, near Selby. Great to meet Gary & Bev in their lovely Leaf Green Frogeye attending their first club social since joining the club in March. Also Peter & Maggie who came in a Naylor MG having recently sold Peter's father's Midget. John & Debbie just back from touring in Europe in their Porsche. Their K-Series Midget is awaiting the fitting of a new alternator following a failure on the way home from the June meeting. A new Spridget contact Dale came along in his Bronze Yellow Midget. We met Dale at a Land Rover run a couple of days before. Hopefully a potential new member as he is very keen to get out and about in his Midget. He told us how he had investigated the club on the internet and had tried to attend the Yorkshire area meeting at the old Saturday venue in Pickhill only to find the pub is now a Chinese restaurant!

Since Dale did his internet search Mark has got our webmaster Mike to update the Yorkshire page to reflect current arrangements, although we probably need a bit more tweaking to get the calendar events list correct. Emma trekked up from Sheffield again in her K-Series and Charlie made it a total of eleven. We heard later that someone had turned up at the June venue and we had a few apologies too.

The September meeting will be run by Rob Armstrong as Mark & I will be away in Edinburgh that evening. Thursday September 19th at The Gait Inn, Millington, York YO42 1TY.

We are planning to have a MASC presence at the York Historic Vehicle Group 42nd Annual Rally on Sunday 22nd September on The Knavesmire at York Racecourse. We will have the Club tent and would love to have a few cars displayed. £5 per car entry in advance

by 10th September. Please contact us on 07471 606060 or 07484 682516 if you are interested.

Anita

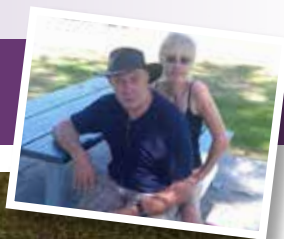

# DEAR MASCOT...

HI NEIL,

You mentioned in August's Mascot about whether the MASC Facebook site should be made members only. This would surely be a negative move to attracting new members to MASC and remove the best marketing tool there is for airing the advantages of membership across to non-members.

The club is trying to attract young members and Facebook must be one of the best ways of attracting the younger generation who use Facebook seven days a week.

My wife and other partners of club members use the MASC Facebook site to keep in touch of club events and plan accordingly, but they would, I presume, be removed from the site if it was made members only.

Yes, there are plenty of other Spridget Facebook pages but are they as good as the MASC group and will they ever attract new members to MASC? Fellow members regularly point out the advantages of joining MASC. They advertise the great monthly magazine Mascot and mention its articles, which are always of interest to members and there is nothing included that should only be available to paid up subscribers.

Unfortunately, websites are not as popular as they were and removing access to non-members of the MASC Facebook Group would be a backward step. This seems a strange option when it's become so popular and well managed not allowing any non Spridget interested people access.

Regards,

**TIM LYNAM**

HI NEIL,

I was interested to read your comments is MASC this month.

I opened my first Facebook account earlier this year specifically to access the MASC group. I think Richard directed me there, after I questioned why the website forum didn't really seem to have any activity. I actually operate under a pseudo name as I am very careful about my "cyber footprint". I have all the privacy settings on and only follow MG groups.

I have to say I do love it, and comment almost daily. I've had my midget 30 plus years, and am four years into a rebuild. I'm 51. As it's not on the road, I'm not really able to participate in the social side of MASC (although look forward to in the future). I really enjoy the daily banter about all things Midget with largely like minded folk, and have have some very helpful advice. It's fun to share the outcome and tribulations of an afternoon in the garage, although the content is rarely worthy of a MASC article!

I wonder whether you could set a page or two up in MASC each month on a topic and invite members to submit tips and comments - almost twitter style

with a short word limit and maybe photo. Eg Fitting a hood, rebuilding suspension, home painting etc. Just a thought, and might capture more of the informal Facebook type content.

It hadn't occurred to me that many of the users of MASC Facebook weren't members. Does seem a bit cheeky, but it is an excellent group so would be a shame to limit it. Perhaps new member requests should only be granted to MASC members? Maybe there could be a reduced digital membership?

I don't think those non Facebook members would see much change if you dramatically reduced the current group. It's such a shame that some people are still so against social media, as they really miss out its amazing potential. It's like the tide - you can't push back on it! Far better to embrace it, and learn how to do it properly and understand where the risks lie and how to be protected. Could MASC run a feature on how to set up an account safely?

Sorry, rather a ramble! Needless to say, receiving the print version of MASC is still a highlight of the month. You and the committee do a brilliant job.

Kind regards,

**ALEX MCKINLAY**

# THE WHO, THE WHAT & THE WHERE OF THE MIDGET & SPRITE CLUB

## COMMITTEE

CHAIRMAN  
GENERAL SECRETARY  
TREASURER  
EDITOR

AREA REP'S DELEGATE  
MEMBERSHIP

GENERAL MEMBER

YOUNG PERSONS REP  
FACEBOOK COORDINATOR  
MARKETING OFFICER

Mark Hall, T: 01296 660103 E: [chairman@midgetandspriteclub.co.uk](mailto:chairman@midgetandspriteclub.co.uk)  
Glyn Polly, T: 07544 302 575 E: [glyn.polly@ymail.com](mailto:glyn.polly@ymail.com)  
David King, T: 01453 544202 E: [djs.king46@gmail.com](mailto:djs.king46@gmail.com)  
Neil Thomas, T: 07891 684435  
E: [editor@midgetandspriteclub.co.uk](mailto:editor@midgetandspriteclub.co.uk)  
John Collins, E: [green\\_mx5@hotmail.com](mailto:green_mx5@hotmail.com)  
Stuart Watson, "Staddlestones", Thicknall Lane, Clent, Stourbridge, West Midlands. DY9 0HX.  
T: 01562 883076 E: [membership@midgetandspriteclub.co.uk](mailto:membership@midgetandspriteclub.co.uk)  
Alan Pritchett, T: 07720 238810 E: [a.pritchett@btinternet.com](mailto:a.pritchett@btinternet.com)  
Gary Lazarus, E: [garyfrogeye@gmail.com](mailto:garyfrogeye@gmail.com) T: 020 7700 5696  
Anthony Cutler, E: [anthony.cutler@btinternet.com](mailto:anthony.cutler@btinternet.com)  
Richard Weaver, E: [fsam1983@hotmail.com](mailto:fsam1983@hotmail.com)  
Liam Murphy, E: [biddysingh@gmail.com](mailto:biddysingh@gmail.com)  
Richard Wharmby, T: 07814 764546 E: [r.wharmby10@virginmedia.com](mailto:r.wharmby10@virginmedia.com)  
Clare Nedin, [marketing@midgetandspriteclub.co.uk](mailto:marketing@midgetandspriteclub.co.uk)

## OFFICERS

CLUB ARCHIVIST &  
TECHNICAL DOCUMENTATION  
MEMBERS ADVERTISING  
CAR REGISTERS  
SPRITES & MIDGETS  
(EXCEPT MK1 SPRITES)  
SPRITES MK1  
REGALIA OFFICER

TECHNICAL ADVISOR  
WEBMASTER  
TRADE ADVERTISING  
ENQUIRIES

Terry Horler, 63 Littledean, Yate, Bristol, BS37 8UQ. T: 01454 881770  
E: [rebelwithasprite@hotmail.com](mailto:rebelwithasprite@hotmail.com)  
Neil Thomas, T: 07891 684435 E: [editor@midgetandspriteclub.co.uk](mailto:editor@midgetandspriteclub.co.uk)

Stuart Watson, E: [stuart@thewatsonz.com](mailto:stuart@thewatsonz.com) T: 01562 883 076

Gary Lazarus, [garyfrogeye@gmail.com](mailto:garyfrogeye@gmail.com) T: 020 7700 5696  
Mike Grout, 55 Park Road, Spixworth, Norwich, NR10 3PJ. T: 01603 890211  
E: [miketg54@hotmail.com](mailto:miketg54@hotmail.com)  
Mark Boldry, E: [mark26r@hotmail.com](mailto:mark26r@hotmail.com)  
Mike Bennett, [webmaster@midgetandspriteclub.co.uk](mailto:webmaster@midgetandspriteclub.co.uk) T: 01925 727479  
Gary Lazarus, [garyfrogeye@gmail.com](mailto:garyfrogeye@gmail.com) T: 020 7700 5696  
E: [enquiries@midgetandspriteclub.co.uk](mailto:enquiries@midgetandspriteclub.co.uk) / [alan.anead@btopenworld.com](mailto:alan.anead@btopenworld.com)

## AREA REPRESENTATIVES

BRISTOL  
CAMBRIDGESHIRE  
CENTRAL  
DEVON  
DORSET  
ESSEX  
HAMPSHIRE  
HEART OF ENGLAND  
HOME COUNTIES  
KENT  
LINCOLNSHIRE  
LONDON  
NORTHAMPTON  
NORTH WEST  
NOTTS/DERBY  
OXFORD  
SCOTLAND  
SOMERSET  
SOUTH WEST WALES  
SURREY  
SUSSEX  
WILTSHIRE  
YORKSHIRE

Terry Horler, T: 01454 881770 E: [rebelwithasprite@hotmail.com](mailto:rebelwithasprite@hotmail.com)  
Graham Kirkup, T: 01223 511835 E: [gramag.kirkup@ntlworld.com](mailto:gramag.kirkup@ntlworld.com)  
Dave Warren, T: 07831 101850 E: [central.masc@live.com](mailto:central.masc@live.com)  
Michael Ellis, T: 07414 279074 E: [michael\\_ellis@live.co.uk](mailto:michael_ellis@live.co.uk)  
John Gully, T: 07876 334949 email [john.gully@btinternet.com](mailto:john.gully@btinternet.com)  
Tim Wyman, T: 07828 245280 E: [essexmidgetandspriteclub@gmail.com](mailto:essexmidgetandspriteclub@gmail.com)  
Terry Langridge, T: 01252 626063 E: [friendlyfolk@maschants.co.uk](mailto:friendlyfolk@maschants.co.uk)  
Dave Colclough, T: 07543641284 E: [dave@colcloughsonline.co.uk](mailto:dave@colcloughsonline.co.uk)  
Mark Hall, T: 01296 660103 E: [markdhall@aol.com](mailto:markdhall@aol.com)  
Alan Anstead, T: 01322 384050 E: [alan.anead@btopenworld.com](mailto:alan.anead@btopenworld.com)  
Jason Elliot, T: 07780 815264 E: [dyke-jason@hotmail.com](mailto:dyke-jason@hotmail.com)  
Gary Lazarus, T: 020 7700 5696 E: [garyfrogeye@gmail.com](mailto:garyfrogeye@gmail.com)  
Andrew Parrott, Mob: 07808 158623 E: [andrew.parrott@btconnect.com](mailto:andrew.parrott@btconnect.com)  
Neil McLeod, T: 01772 466648 Mob: 07921 089 680 E: [neil\\_mcleod2@outlook.com](mailto:neil_mcleod2@outlook.com)  
Ian Cooke, T: 0115 938 3838 E: [ilcooke@btinternet.com](mailto:ilcooke@btinternet.com)  
Grahame Gibbins, T: 01235 530456 E: [grahame\\_gibbins@hotmail.com](mailto:grahame_gibbins@hotmail.com)  
Graham Smith, T: 01411 954 8276 E: [smith.grahamf@yahoo.co.uk](mailto:smith.grahamf@yahoo.co.uk)  
CURRENTLY VACANT  
David Hill, T: 01239 811307 E: [david@hill.be](mailto:david@hill.be)  
Mike Gorman, T: 01737-552256 E: [gorman698@btinternet.com](mailto:gorman698@btinternet.com)  
Chris Harding, T: 01342 718860 E: [harding.cm@btinternet.com](mailto:harding.cm@btinternet.com)  
Andy Cross, T: 01225 743554 E: [andyspeedbox@gmail.com](mailto:andyspeedbox@gmail.com)  
Mark Boldry, T: 07471 606060 Anita Lachowicz T: 07484 682516 E: [spridget.girl@gmail.com](mailto:spridget.girl@gmail.com)



**ALSO SEE THE CLUB NIGHTS SECTION FOR NEW AREAS AND CONTACTS**

Compiled by Neil Thomas. Please advise me of any changes, errors etc.

### MEMBERSHIP RENEWAL:

If you experience "MASCOT" problems upon renewal, please contact the membership secretary or the treasurer straight away.

# CLUB NIGHTS



- 3rd Thursday **YORKSHIRE AREA.** Thursday 20th June, meeting for the Yorkshire area will be at The Anchor, New Road, Whitley, York YO26 8AG from around 7PM – For further details contact Mark Boldry 07471 606060 or Anita Lachowicz 07484 682516 - email: spridget.girl@gmail.com
- 1st Tuesday **ESSEX AREA.** From May – September we meet on the first Tuesday of the month for a car run, ending in a pub for an evening meal. Please contact Tim Wyman tel 07828 245280, email address essexmidgetandspriteclub@gmail.com for more details.
- 1st Wednesday **CENTRAL AREA.** Now meet each month 8.30pm onwards at the Tame Otter, Lichfield Road, Hopwas, Tamworth, B78 3AF, 8.30 pm onwards Contact: Dave Warren, Tel: 07831 101850. Email: central.masc@live.com
- 1st Wednesday **OXFORD AREA.** Meet at the Blackhorse Pub, Gozzards Ford, Nr Abingdon. 7pm for those eating or 8pm for those not. Contact Grahame Gibbins at grahame\_gibbins@hotmail.com
- 2nd Tuesday **LONDON AREA (CONGESTION ZONE).** Meet at The Ace Cafe at 7:30pm together with the Classic Cars Magazine night. Details: Gary Lazarus on 020 7700 5696 garyfrogeye@gmail
- 2nd Wednesday **DEVON AREA.** Meet at Court Farm, Abbotskerswell, TQ125 NY Devon. 7.30pm Michael Ellis Michael\_Ellis@live.co.uk and telephone: 07414 279074
- 2nd Wednesday **HEART OF ENGLAND.** All welcome at the Green Dragon, Sambourne, Redditch B96 6NU 8pm gathering for a 8:30pm start. Further information from Dave Colclough on dave@colcloughsonline.co.uk or 0754 3641284.
- 2nd Wednesday **NORTH WEST AREA.** Meet at The Kilton, turn off M6 at Jct 20 onto A50 towards Macclesfield. Pub 4 miles on left. Please note new venue. Neil McLeod email neil\_mcleod2@outlook.com Tel 01772 466648 Mobile 07921 089680
- 2nd Wednesday **BRISTOL AREA** will meet at Wishing Well, Wapley Road, Codrington, Bristol BS37 6RY. From 8.00pm – or earlier for a Curry enjoyed in peace! Contact Terry Horler 01454 881770 rebelwithasprite@hotmail.com
- 2nd Thursday **NOTTS/DERBY BORDER AREA.** The Hunters Arms at Kilburn, DE56 0LU (just off the A38) from 7.30. Ian Cooke 0115 938 3838 ilcooke@btinternet.com
- 2nd Thursday **CAMBRIDGESHIRE AREA.** Meet at The White Swan, Elsworth Road, Connington, Cambs CB23 4LN from 8pm
- 3rd Thursday **NORTHAMPTON AREA.** The Red Lion, Welford Road, Thornby, Northamptonshire, NN6 8SJ from 8pm
- 4th Thursday **LINCOLNSHIRE AREA.** Meeting at The Wishing Well Inn, Dyke, PE10 0AF from 7 o'clock onwards.
- 2nd Sunday **EAST KENT GROUP.** Meet at the Crown Inn, Sarre, CT7 0LF from 12.30hrs Contact Area Rep alan.anstead@btopenworld.com or John Clark group co-ordinator jrclark@sky.com
- 3rd Tuesday **SCOTLAND.** Meet at Houstoun House Hotel, Broxburn, EH52 6JS. Meetings start at 7.30pm. Graham Smith 0141 954 8276 email: smith.grahamf@yahoo.com
- 3rd Tuesday **SURREY.** Meet at The Blue Ball, Deans Lane, Walton-on-the-Hill, Tadworth Surrey KT20 7UE. 7.30pm onwards. Contact Mike Gorman, gorman698@btinternet.com Tel: 01737 552256
- 4th Monday **DORSET.** New Venue: Charlton Inn, Bournemouth Road, Charlton Marshall, Blandford Forum, Dorset DT11 9NH about 7.30pm
- 4th Thursday **SUSSEX.** Meet at Bolney Stage, Bolney, RH17 5RL from 19:00.
- 4th Thursday **HAMPSHIRE.** Meets at The Millhouse, North Warnborough, Odiham, RG29 1ET. Please ring Terry or Harriet Langridge on 01252 626063 for details.
- 4th Sunday **KENT AREA.** Back at The Angel, Addington Green, Kent until further notice. Contact Alan Anstead enquiries@midgetandspriteclub.com
- Last Monday **WILTSHIRE.** Meet at The Barge Inn, Seend, Nr. Devizes, about 7pm. Contact Andy Cross on 01225 743554 or email andyspeedbox@gmail.com
- Last Wednesday **HOME COUNTIES NORTH WEST** for members in Herts, Beds, Bucks, Berks, N. London or anyone interested! Meet at the Chequers Inn, Redbourn, AL3 7AD from 6:30pm. Please contact Mike or Sue Gahan on email mike@mgahan.demon.co.uk or on 07850 488636.
- Last Thursday. **SOMERSET AREA.** Non-regular and occasional meetings and runs arranged throughout the year. Please contact Colin Chorley email: chorleycchorley@aol.com for further information. Northern Irelanderbertholmes25@hotmail.com. If enough interest, will arrange a meeting.
- South West Wales Non-regular and occasional meetings and runs arranged throughout the summer months. Please contact David Hill on 01239 811307 or email: david@hill.be

# MARKET PLACE



**FOR SALE:** 1958 Austin Healey Frogeye Sprite Mk 1 British Racing Green c/w 9 stud windscreen, 1275 engine with fast road cam and gearbox, disc brakes on front, larger rear brakes and 3.9 diff but nothing that could not be rebuilt to standard if required - Unfortunate forced sale due to ill health - Any trial @ £19,500.00 ono - Contact John Platt. 01789 488321 / johnplatt1275@btinternet.com



**FOR SALE:** Midget / Sprite hardtop £175.00 ono. Please text / phone 07791 534607 (Merseyside)

**FOR SALE:-** 1972 MG Midget Mk 111.Round wheel arch model.Bare metal re-spray in 2017,finished in Blaze Orange. Regularly garaged and mostly dry run. Fitted with new brakes, master cylinders,carpets and stainless steel exhaust.Good soft top and tonneau cover. Only minor fault is a slightly noisy first gear but it has been like this since I bought the car 11 years ago. Large file with all relevant paperwork,MOT certificates etc. Club valuation of 8,500. Looking for offers around 7,500. Mobile. 07807 512923 E.mail gbmck51@gmail.com. George McKinnon



**FOR SALE:** Frogeye. I am looking for £13,000. alanvthomas19@btinternet.com

*The Original Austin-Healey Sprite Parts Specialist*



## New LED Light Upgrade Kit Available



We are excited to introduce our new range of LED lighting upgrade kits for Austin-Healey Sprite MK 1 Frogeye.



Available in both positive and negative earth, each kit contains the indicator relay and correct number of LEDs to replace both the exterior and interior bulbs in your Frogeye.

### LED HEADLIGHT:

**XLTG133** Headlight Bulb Kit

### LED BULB UPGRADE KIT:

**XLTG240** Positive Earth

**XLTG241** Negative Earth

[www.ahspares.co.uk](http://www.ahspares.co.uk)

# Frogeye Spares

*"Knowledge, Expertise & Passion"*



## The Manufacturer of Wheeler & Davies Frogeye Bodyshells

Virtually EVERYTHING in stock  
to build a complete Frogeye!

Specialising in new & used parts, complete  
new body shells, servicing & restoration  
of Austin-Healey 'Frogeye' Sprites.

For all your Austin-Healey Sprite needs, look no  
further for friendly service and competitive prices!

Call the experts today on  
**+44 (0)1204 604 017**

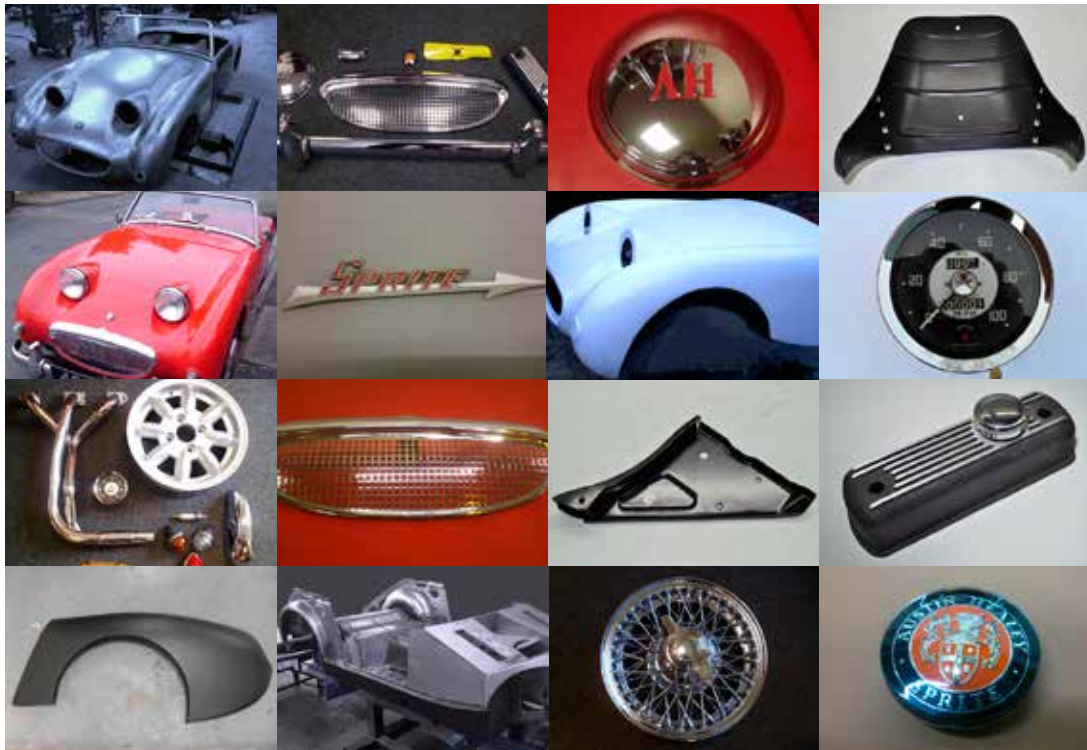

Visit [www.frogeyespares.co.uk](http://www.frogeyespares.co.uk) or email [enquiries@frogeyespares.co.uk](mailto:enquiries@frogeyespares.co.uk)