

MASCOT

THE MAGAZINE OF THE MIDGET & SPRITE CLUB

ISSUE 471 DECEMBER 2018

£3

Happy Christmas



**OUTSTANDING CLUB
MAGAZINE OF
THE YEAR 2018**
HIGHLY COMMENDED



www.midgetandspriteclub.co.uk

AN ASHLEY DISASTER BY PETER NEACHELL

ONCE, TWICE, THREE TIMES A MIDGET BY MARK DEVERAUX

ALSO IN THIS ISSUE: COLIN THE CHAMPION • FRODO AT KOP HILL • A BETTER HORN

**Specialist vehicle
insurance from
people who share
your passion.**



rhspecialistinsurance.co.uk

0333 043 3911



From iconic models to future classics –
we've been providing specialist vehicle
insurance for over 40 years.

WELCOME TO THE DECEMBER EDITION OF MASCOT

NEIL THOMAS

editor@midgetandspriteclub.co.uk



Hi everyone, not many days left now before Christmas is upon us. I'm sure, that like me, you have felt that this year has just flown by. It has been such a busy year for our club with the 60th anniversary of the Sprite forming a significant part of it. It's been great and I have thoroughly enjoyed being part of MASC. The most recent big event, the NEC Classic, epitomises the camaraderie that the club engenders with lots of members willing to give up their spare time to come and help out and the large number of visitors attending at the stand to say hello and have a chat. Thank you Alan Pritchett for all your hard work.

We have a great membership and some fantastic volunteers ensuring that events are organised and everything runs smoothly. Personally I would like to extend my heart felt thanks to all those of you who have taken the trouble to send me articles and pieces for the magazine. Without your contributions MASCOT wouldn't be what it is now. So thank you. I'd also like to thank my fellow committee members who have supported me in my role as Editor. You have been great and I know the members appreciate you too. Also thanks to all at Quorum and to my friend Andy Barrass for his support.

I must also mention here Valerie Young and her consort Peter who is stepping down as Area rep for Somerset after 5 years in the role. Thank you Val and for your timely reports each month. I hope to see you again at some stage in the future.

On a sad note I want to pay respects to Richard Ladds who sadly passed away on the 2nd October. Richard was the editor of the MGOC magazine, "Enjoying MG" for 22 years and was a real gent. I'm sure many of you will have known of him. He was a real MG enthusiast and a very decent man. My sincerest condolences go to his family.

On a lighter note, I was delighted to see a group of Thames Valley based MASC Spridgeteers meet up recently on an impromptu get together and follow a route prepared by Steve Goodchild, following the upper reaches of the Thames and visiting places like Wallingford, Abingdon, Henley on Thames etc. Well done Steve. This is how Areas are formed with a small group of enthusiasts developing the yen for getting together and enjoying themselves. Perhaps there is a new Area forming here?



Well that's all from me now for 2018. Sharon and I would like to wish you all a very Happy Christmas and a prosperous and peaceful New Year. **Neil**



COVER IMAGE:
BY DAVE CHALK
DECEMBER 2017

The statements and opinions expressed in each and every issue of Mascot are not necessarily the considered views of the Midget and Sprite Club. The views expressed by the editorial contributors, letter writers and advertisers are their own and do not necessarily reflect the view of the Club. The Midget and Sprite Club accepts no responsibility for the results of following contributor's advice, nor does it necessarily endorse the services or products offered by advertisers.

THE DEADLINE FOR ARTICLES
AND REPORTS TO BE
INCLUDED IN **JANUARY'S**
EDITION OF MASCOT IS...

**FRIDAY 7TH
OF DECEMBER**

EVENTS CALENDAR 2019

- 10 Feb MG & Triumph Spares Day, Stoneleigh
- 22-24 March Practical Classics and Restoration Show, NEC 2019
- 3-5 May Donington Historic Festival
- 26-38 July Silverstone Classic
- 28 Aug - 9 Sept A tour through Belgium, France & Germany, visiting places of interest on the way, to the Swiss Alps: there to experience Swiss alpine passes. Return via France. A tour for Sprites, Midgets, & Derivatives Only.
Contact: alan.anstead@btopenworld.com



Send your events details to editor@midgetandspriteclub.co.uk
Area Reps, Please remember that you can now add your monthly events on the Club's website.
Please contact Mike webmaster@midgetandspriteclub.co.uk

EVENTS DETAILS NEEDED FOR 2019

Area reps please make Neil Thomas aware of any events already in your diaries and any that are planned for 2018/2019 so that they can be added to this section of the magazine and the website.

For the magazine Neil can be contacted at editor@midgetandspriteclub.co.uk
For the website Mike Bennett can be contacted at webmaster@midgetandspriteclub.co.uk

MG Peaks to Lakes Run September 2019



**View from Wrynose Pass,
Lake District**

Cat and fiddle, Peak District

TO



The Peaks to Lakes Weekend Run will be 6th-8th September 2019.

The event is limited to 200 people. Contact: norman@frenchbbat.com for entry form

Hotels are block booked at reduced prices, lunches and tea stops arranged as well as banquets for each night.

The trip includes a surprise visit to a Lake District attraction.

The cost of the trip is £35 payable in May. At least £20 of that will go towards one of the meals. It is planned to get sponsorship money from the hotels and if we do the subsidy can rise to £25. This is a strictly not-for-profit event.

BOOK BEFORE END OF FEBRUARY TO BENEFIT YOUR CLUB**



practical
CLASSICS

**CLASSIC CAR
& RESTORATION SHOW**

With **Discovery**

SPRING'S BEST CLASSIC CAR SHOW

22-24 MARCH 2019 • NEC BIRMINGHAM

1,000 classic cars on display | Over 160 classic vehicle clubs | Live restoration demonstrations
350 specialist exhibitors & traders | Spring's largest indoor autojumble
Lancaster Insurance Pride of Ownership | Classic cars for sale with leading dealers
Classic Car Auctions two-day sale | Practical Classics live stage with Discovery | Carole Nash Barn Find display
The Workshop, sponsored by Skill Shack | Sporting Bears Dream Rides Garage

BOOK TICKETS NOW TO SAVE!
EXCLUSIVE CLUB DISCOUNT ON SATURDAY OR SUNDAY TICKETS*
NECRESTORATIONSHOW.COM | QUOTE YOUR CLUB CODE C3911RS19

In association with



ClassicCars



Official Show Partners



*Savings are based on on-the-door ticket prices. Savings are pre-applied to all prices on the website. The code stated above is used for marketing purposes only. To book by phone, call 0844 858 6758. Calls cost 7ppm plus network extras. All bookings are subject to a single transaction fee of £1.95. Tickets include a show guide worth £4.00. Advance tickets are available until midnight Thursday 21st March. After that date, tickets will only be available at the show. All information correct at time of publishing. Full T&Cs online at necrestorationshow.com.



For some it's the age...



For some it's the iconic status...



For others it's the marque...

Whatever your definition of classic we know you love it.

Here at 2Gether we feel the same and have done so for over a decade.

Tailor made specialist insurance solutions from the specialists.

Some of the benefits our policies can provide:

- Club Member Discounts
- Agreed Value
- Limited Mileage Discounts
- Free Legal & Accident Management Cover
- Breakdown Cover

2getherinsurance.co.uk

01945 586220



SNAP! OF THE MONTH

To submit your photo by email to editor@midgetandspriteclub.co.uk (jpeg, max file size 5MB)



Above - Barney

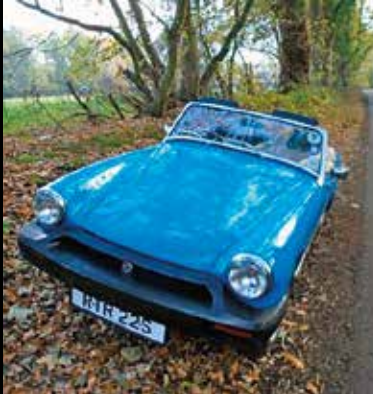

Les Jean's Midget Autumn shot



Scruffy waiting for lift to France



John and Jayne and Robin at Les Roussines



Snowy Sprite

SNAP!

NEW MEMBERS

OCTOBER > NOVEMBER 2018

We extend a warm welcome to the following new and rejoined members

5772	Alan Reid	South Lanarkshire	Sprite	Mk 1
5773	Caroline Bell	Oxfordshire	Sprite	Mk 1
5774	Stephen Toms	Shropshire	Sprite	None
5775	Jago Hurley	London	Sprite	Mk 1
5776	W Burkinshaw	Bukinghamshire	Sprite	Mk 1
5777	David Jones	Somerset	Sprite	IOW Frogeye
5778	Nick Davies	Warwckshire	Midget	Mk 3 RWA
5779	John & Glenys Lister	Conwy	Midget	Mk 3 RWA
5781	Chris Palmer	West Midlands	Midget	Mk 3
5782	Tony Phillips	Leicestershire	Sprite	Mk 3 RWA
5783	Chris & Sarah Evans	Surrey	Midget	Mk 3 RWA
5784	Chris Richards	Shropshire	Midget	1500
5785	Martin & Angela Gosling	Hampshire	Sprite	
5786	Helen Jones	South Wales		
5787	David Waterhouse	Warwickshire		
5788	Lauren & Will Goldsmith	Kent	Sprite	Mk 1
5789	Dave Burgess	Staffordshire	Sprite	Mk 4
5790	Yves Cozon	Warwickshire	Sprite	Mk 1
5791	Gary Downes	Cambridgeshire	Sprite	Mk 2
5792	Graham Trickett	Warwickshire	Midget	Mk 3
5793	Harry Hadden-Wight	Surrey	Midget	Mk 3
5794	Geoff & Lisa Woodfield	West Midlands	Sprite	Mk 2
5795	Pascal Flynn	Ireland		
5796	Chris Boughen & Jeanette Chambers	Carmarthen	Midget	1500
5797	Simon Ellis	Leicestershire	Midget	1500
5798	Tulio & Lorraine DiFrancescoMarino	West Sussex	Midget	1500
5799	John Faux	Hampshire	Midget	
5800	David Young	Hampshire	Sprite	Mk 1
5802	Helen & Gary Anderson	Buckinghamshire	Sprite	Mk 1
5803	Ian Gallow	Aberdeenshire	Sprite	Mk 1
5804	Francis Wilson	Buckingham	Midget	Mk 3 RWA
5805	David Evans	Shropshire	Midget	Mk 3
5806	Peter Good & Victoria Yong	West Midlands	Sprite	Mk 3
5807	Steve Sumner	Hertfordshire	Midget	Mk 3
5808	Graeme Payne	Surrey	Midget	Mk 2
5810	Mark Forrest	Staffs	Midget	Mk 3
5820	Henry Bendell	Surrey	Sprite	Mk 4
5821	Michael Meerlo	Netherlands	Sprite	Mk 1
5822	Lesley & Edward Peel	Yorkshire	none	None
5823	Graham & Barbara Bracegirdle.	Lancashire	Midget	Mk 3

Hello Neil, I'm Dave and I've just joined the club - mem No 5800

Attached is a photo of myself and wife Noreen with our Frogeye arriving home.



The car is a 1961 Mk 1, and was originally owned by me having purchased her in 1971, for £30.

Shortly afterword's I went off travelling with a friend of mine around Australia, having 'dumped' the Frogeye in my brothers back garden under a tarpaulin. I ended up staying in Oz, and my friend returned after 3 years. My brother, now fed up with this 'heap of rubbish' under the tarpaulin sought my agreement to allow my friend to take it away which I agreed.

Now..... move on many years. I'd returned to the UK and unfortunately my friend passed away last year. Whilst attending his funeral, his brother asked me if I remembered the old Frogeye and then stunned me by saying it was at their home and had been under wraps for about 40 years ! I went to see it and was astonished to see it in the same condition as I'd left it ... apparently my friend was always intending to renovate it. I even managed to find the original folding log book in my loft, along with some photos of a very young looking me in overalls welding the floor ! His family thought it only right that the car should return to me to complete the renovation watch this space !

Dave /Noreen - Langley, Hampshire

Hello Neil, I have just joined the club, and Stuart has asked me to send you a photo of our sprite (actually belongs to my son Henry, but I look after it) for the welcome pages of the magazine.



Kind Regards, Yves Cozon

Hi Neil,

Here is a photo of our Sprite as requested, shame about the wing mirrors :(



**Best Regards,
Peter**

We bought our 1979 Midget 1500 in April 1916 with full history and a documented 12,500 miles on the clock. It is completely unrestored and original and is remarkably rust free having had a Ziebart treatment early in its life. Unfortunately, from a cosmetic point of view, the engine bay and boot interior were covered in black Waxoyl at the same time. Where we have replaced parts for modern convenience, e.g. electronic ignition, we have cleaned and stored the originals so the car can become factory original with little effort. Currently running on Minilites as the Rostyles need a bit of a tidy up.



The photo was taken on the Circuit Historique de Laon in 2017. We were having a drag race (on a closed road) with friends in their TR5...you can guess the result of that!

Chris Boughen & Jeanette Chambers (5796A/B)

I've owned the car since 1978, when it had just 14,000 miles on the clock, it has now done 168,400.



It now has an Oselli 1293cc engine producing 93bhp, and is supposed to rev to 7,500 rpm, but I try to keep it below 6,500. It also has a Ford 5 speed gear box, Frontline front suspension, 123 electronic distributor and LCB exhaust system, plus lowered and stiffened suspension.

During the late '70's and 80's, I used it for sprints and hill climbs, it was standard then and I picked up a few pots. However I decided to modify it as I wanted to have a bit more fun, but I was then up against cars with fibreglass panels, stripped out interiors, etc., so it was no longer competitive. I then discovered track days and was one of the early MG's on track members. My local circuits are Anglesey and Oulton Park, but have travelled to Silverstone, Donnington, Castle Combe, Cadwell Park (to name a few), where I enjoy giving it some serious stick!!

**John & Glenys Lister
Membership no. 5779**

COLIN & KERMIT 2018 CHAMPIONS



Coming from humble beginnings, my Dad never had a car when I was a young boy. I was always keen on watching cars race and I used to ride my bicycle 7 miles to Castle Coombe to see Sprites, Minis & Imps amongst others, battling it out around the track and in so doing, beating bigger more powerful machines. I loved it.

I had previously bought toy cars with pocket money to zoom across the playground at primary school. Later I went to motor shows at Earls Court and to racing and Sports Car shows at Olympia, in the school Minibus. Those were some great trips, all very Nostalgic or “Retro” now.

Whilst at school I also took an interest in Art, you guessed it, I drew and painted cars on circuits.

My enthusiasm continued throughout my life when my dream became a reality and I was able to buy a Sprite suitable for Sprints & Hillclimbs.

As some MASC members know, the Austin Healey club run a Sprint & Hillclimb Championship throughout the year. We have just had our drivers meeting at Gaydon to select the event invites for next season. These will include, Curborough, Gurston, Harewood, Loton Park, Shelsley Walsh and Castle Coombe plus others. There were 13 Sprites and 15 Healey 3000s registered last year.

I did meet many of you, this last year, at different venues that I competed at. I took part in 9 events out of 15 on offer. Some of these events are on scratch results, others are on Target times which is usually your personal best for that venue.

I managed to win 5 events and set personal bests, making me the overall champion for 2018. It has taken me many years to achieve this thanks to my very green FR06 EYE sprite 1380cc with 45 Weber. For me it is living the dream.

The Big Healey class was won by Richard Mason in his “3000 Beast”.

If you are at all inspired to “have a go” in what is a relatively cheap entry into Motor Sport, which will guarantee to put a smile on your face, please visit Healeysport.com or see the Facebook page.

“Have a Happy Christmas and a healthy & prosperous New Year.”

Photos from: JCB photography, David Copley, Keith Wilson and Dee Brady

FRODO GOES TO KOP HILL



Kop Hill is a 2/3 mile incline on the outskirts of Princes Risborough, Buckinghamshire. From 1910 until 1925 motorbikes and cars vied to be the fastest to complete the (previously gravel, now tarmac) track, with some reaching speeds in excess of 80 mph. Following an 84 year absence the event was revived in 2009 but this time with a different emphasis. Unlike other hill climbs it's no longer about getting to the top as fast as possible. As the chief marshal emphasised during the drivers' briefing "usual traffic rules apply".... and that applies to speeding! The whole purpose of the Kop Hill Climb Festival, which takes place mid-September, is about raising money for charity. Since 2009 they've raised over half a million pounds and had 100,000+ spectators.

As a car owner and driver I love the event's relaxed atmosphere and the variety of cars which attend. The focus of the event is cars and motorbikes over 30 years old, with some limited "exotic moderns". This year the oldest motorbike was a 269cc 1914 Sun Villiers. The oldest car was a 1907 Burliet Curtiss and the most modern, the McLaren Senna Supercar. I much prefer the older cars to the newer and the Napier Railton (from Brooklands) always is something to behold.

Driving up the hill, to the cheer of the spectators, is a real buzz and this is magnified when you make your way back to the paddock area which involves passing people's drives where they've set up table and chairs for the day to watch the procession of cars and through Princes Risborough town centre where people are lining the roads, smiling, waving and taking photos. I also forgot to say my father comes as my passenger and he is like a kid in a sweet shop, or should that be Cheshire cat? The only slight frustration is why do the interviewers assume that if a male is in the car, even in the passenger seat, that the vehicle is his? Grrr.



While not on one of his 2 runs up the hill, Frodo was on display in the entrants' paddock area. Next to my Mark 1 Sprite were a Fairthorpe Electron Minor and a Triumph TR3, all 1959. I shouldn't be surprised but it was interesting to spot the number of common parts between the cars, same tail lights, indicator lights etc.

In addition to all the amazing cars, Kop Hill has some great music, local falling down water (for the non-drivers), food and a soap box challenge for kids and is a recommended day out. My only tips are that if you want to go up the Hill you need to apply early and keep your fingers crossed for good weather.

What's next for Frodo? After all the excitement of Wroxall Abbey and Kop Hill – he needs his gearbox sorted, (Kop Hill was driven without the use of 1st gear!) and action taken to eradicate/reduce the engine oil leaks which have got much worse recently (there are only so many times you can try and remove an oil trail from a tarmac drive).



ONCE, TWICE, THREE TIMES A MIDGET...



I would like to introduce myself having just brought ONP 848T to the Midget & Sprite Club, and thought that some folk might be interested to know how I got to own my Midget not just once, but three times.

It's quite a long story, but I first bought ONP 848T in 1980 when she was just 6 months or so old. At the time I was 20 and the MG was part of a deal with my parents to get me away from motorbikes.

It all started when I expressed a strong wish to race bikes for the RAF and was poised to buy a Laverda Jota for the job. My father had raced bikes very successfully himself (Velocettes) and then went on to race home built cars (Austin 7 based). I can just about recall his last racing car in the early 60s when I was not much more than a toddler which looked a bit like a small Shelby Cobra.

Back to 1980, and I was home on leave, and it happened to be one particular Sunday when 'The Money Programme' was on TV reporting on the mess that BL had found itself in, and the impending closure of Abingdon.

My father, while watching this programme, said "Get yourself an MG - you'll have as much fun with one of those as you will with any motorbike!"

I wasn't very impressed with his idea, and distinctly remember going back to my RAF base in South Wales, completely uninterested at the suggestion and even feeling slightly hurt that my own father would want me to own such a car.

A colleague where I worked happened to have a brand new Midget, finished in what I now know was Brooklands Green, I remember finding him one sunny afternoon outside the back of the hangar



cleaning and polishing it and I casually approached him and asked how he got on with it.

He told me he really liked the car and had no regrets at all in buying it, and went on to enquire as to why I was asking about it. I explained my parent's feelings about the proposed bike racing venture, and he sounded sympathetic to my feelings. The conversation eventually led to an offer of a ride out in his MG that very afternoon, which I took him up on.

It was RAF Brawdy in beautiful Pembrokeshire, and we set off, roof down, around the Pembrokeshire coast roads on this gorgeous sunny and cloudless day. This was my first time in any open-top car and I was well and truly smitten; the entire bike and Laverda idea started to rapidly evaporate.

I even remember the registration of that Brooklands Green Midget to this day; FEX 419T. Sadly I don't think it has survived - at least looking on the DVLA site it says there is no record of it.

My parents lived in Cleobury Mortimer during the 1980s, and at the same time as I began looking for a suitable Midget there was a local newspaper printing strike on. My younger brother had a paper-round and recalled delivering just one local paper, (which my father went and asked to borrow!). In that solitary paper was just one MG Midget for sale - it was six or seven months old, white, and in Kidderminster. My father duly arranged a viewing, but this car was far too new and well out of my pocket. However the bank of Mum and Dad and my dear old Grandmother came up trumps and bought the car for me. It was then garaged at my parents for a while so that I could start paying for it. In the

meantime my first car (Escort Mk1 estate) was up for sale to help raise funds.

I finally got the MG on the road just after my 21st birthday.

Apart from briefly selling the car to a young lad in Ludlow in the mid-nineties and buying it back again very soon after, ONP 848T stayed with me until 1999 when I regretfully parted company with her to help fund a house when I left the RAF.

She was sold to a chap in Bicester whom was under strict instructions to contact me first if he was ever going to sell her on. Frustratingly he never did contact me and instead sold it to (I suspect) one of his friends that wanted it and I thereafter lost contact with the cars whereabouts.

Eventually my curiosity got the better of me and I wanted to try and find out what happened to the car, but I had lost contact with the guy I sold it to



1982

and had no leads; all I knew was that according to the DVLA website she was declared SORN and it was like this for years.

I tried to imagine why it was SORN for so long, hoping on hope that it was perhaps undergoing some fantastic chassis-upwards restoration and that it was not the unthinkable alternative – that she could be lying severely damaged somewhere; uncared for and rotting away under a decaying tarpaulin on someone's scruffy front garden.

Then one Friday - the 7th April 2017 to be precise - while doing my usual morning routine on the internet before heading off to work, I almost choked on my coffee and fell off my chair - because there she was! For sale on eBay!

Quite literally I had to walk away from the computer screen before going back and looking again, just to check I was seeing this right! I shot upstairs and excitedly told my wife that I had found my old Midget for sale! Her response was simply "Oh no. You aren't going to buy it are you?" (I'd better explain at this point that my wife is of a foreign disposition unfortunately, and simply does not 'get' the British passion for classic cars).

I soon managed to scrape together some funds, and a few days later I was reunited after nearly 20 years with the car that I had spent a lot of my youth with. I drove her back home with the biggest grin on my face ever, and she now sits in my garage at

last, still in remarkable condition; almost as good as the day we parted company.

Apparently, for some reason, a previous owner had dry-stored her on axle-stands since 2003 - this was in Woodstock just outside Oxford, so I had unknowingly driven past her for years!

A lad from Bicester bought her and she was duly recommissioned, but eventually put up for sale which is when I found her. Sadly though, having saved every MOT certificate; every tax disc; and even the most insignificant receipt since I owned the car, these were all lost along with the spare set of keys. Evidently the car was better cared-for while in my possession!

I'm continually trying to find more ways to make more space in my garage/workshop for this old friend, My garage is where I'm restoring a 1930s Midget (J2) bought in the mid 80s after MG had become part of my DNA and I developed a huge interest in the history of the MG marque as a whole, simply because of this sequence of events that led me to my first MG.

I'm still stunned to get this car back after so many years. My parents were even more stunned when they heard of my news, (and no doubt think I've lost the plot), but they started it all when they suggested I got an MG instead of another motorbike!

**Best Regards,
Mark**



MY START AND FINISH AT COMPETING



My story begins sometime in early 1984, when I met a guy with a midget, called Phil Mayne. Phil

still has the same car now as he had then and this chance meeting led into me joining Ashford Kent Motor Club (AKMC). Phil introduced me to many of his friends,



Paul Bernal, Ryan and his brother Jon, who raced a midget and MGBs respectively. Paul still uses his Midget in competitions.

I was then introduced to what many describe as grass roots motorsport, namely grass Autotests. Upon joining AKMC I was invited to an evening event at the local police skid pan,

There was full tuition from an instructor on how to put the car into a spin but more importantly, how to retrieve it. It sounds like fun and I was quite happy throwing my 2 year old Vauxhall Chevette (I was only 23 at the time) around the circuit, when all of a sudden a moment of oversteer set in. I'd only had the car a couple of weeks and the fear of damaging it was not a good thought, there was a 2 foot high bank at the edge,

Without thinking, I followed what I'd been taught, that is take your feet away from the pedals and steer in the direction you want to go, Hey, it worked, so I gained confidence.

Throughout the summer I attended more events and loved them, My folks were not keen on me using my road car for events so another one had to be found, A guy called Andy Gibson (who runs the Arkley SS club) had a blue midget for sale, of which on the 6th October 1984, I became the proud owner of. It was MG Midget, RGN 703E, complete with 1330cc engine, a flip front, fibreglass rear and limited slip diff. It had been used as a competition car.

Within 2 weeks I'd painted it red (with a brush) and the wheels black although these were changed to white within a week or two. My first event in the car was a tarmac Autotest at West Malling airfield, (now called Kingship housing development) on 18th November 1984. I had a good day and was 1st in the Sports Cars and Minis class.

In 1985, I bought a trailer, so the Chevette went and now had a Cavalier mk1.

Over the winter the engine was rebuilt and I entered the Maidstone and mid Kent round of the BTRDA Autotest, alas these guys were good and with a 5th in class being not too bad, the event showed up a lot of faults.

The MGCC event at Silverstone was up next and along with Barry Called and Phil Mayne, we came 2nd in the California cup. Throughout the summer further events were entered, including an event at Valance school, near Sevenoaks. This was a hill climb event on the driveway leading up to the school.

In September 1985, at Bodiam Hillclimb in Sussex, I entered my car as road going, but due to the very high entry, the class was split at 1600cc. I looked at the entry list; 2 Lotus 7's, a Davian kit car and other very nice cars. I only had 1330cc, so I thought to myself, have fun and enjoy it. The 1st 7 cars were separated by just 1 sec and I was first! Drive it like I stole it I'd told myself. At the end October 1985, at a speed slalom at West Malling air field, I had fastest time of the day. A month later, things weren't so good as the gearbox broke.

Overall however, 1985 was a good year as I won the Maidstone and mid Kent driver of the year award.

My 1986 season started with a very noisy gearbox and a burnt out clutch. These were fixed so I entered the Valance Hillclimb again. This was lots of fun and I did beat a Porsche Carrera although, in fairness, I was less worried about crashing my car than he. Bodiam Hillclimb was also entered and even though I was quicker than last time out, I could only manage 4th, but I had entered the modsport class. In the summer of that year I had my first time on a proper circuit, Goodwood. It was a sprint, standing start, flying finish, 126.16 sec, or 2 min 6.16 sec whichever you prefer.

I continued competing in the car until 1992, undertaking various upgrades to the car, eventually selling the car in 1997 to Peter Tipper. The last I know the car was in the hands of Mark Boldry.

During my time competing I kept a scrap book and hence my ability to recall dates and venues. It's proved useful for putting together this little article.

I enjoyed my time competing and would recommend such activity to other MASC members.

Happy Christmas all.

AN ASHLEY DISASTER



It started with an idea some 5 or 6 years ago. I wanted to create a Midget incorporating my favourite parts from the 20 year Sprite and Midget range. I had mentioned this to a few people and one afternoon I got a call from my brother-in-law, Chris, to say there was a 1973, tax exempt, round wheel arch Midget for sale locally. We went to view the car and discovered it had languished on the owner's drive for some 5 years waiting for some much needed TLC.

For me the car was ideal for my project. It had the round rear arches and needed a complete restoration, so the price was right. I parted with £750 in exchange for my new project.

My large double garage was cleared ready for action and the car installed. I know my way round these super little cars quite well, having restored a 1966 Mk III Sprite and a 1959 Frogeye, both of which we still own. So the first step was to strip the car to a bare shell, a task I really enjoy because you get right to the bones of the job. I purchased a body rotisserie and bolted the two together. What a great piece of kit, it is a must for a retired restorer, if you get my drift. I made a jig from 25mm square box section to keep the door gaps and body width intact before removing the inner and outer sills and the full floor section.

Working on one side at a time, to keep the structure as solid as possible, I replaced the panels on the nearside. The rear spring hanger had collapsed, so that got new metal welded in to bring it back to its original spec. I did not remove the door so I was able to check the gaps throughout this part of the work. Shut gaps are so important to the final look of the car. Floor, inner sills, outer sills and spring hanger replaced, I removed the door and replaced the A post. Door rehung, gaps all good, one side looking like new again.

The offside followed and went well without any problems. I can't stress enough the benefits of



using the rotisserie. I was able to position the shell at any angle I wanted, enabling me to access any joint etc. with ease. This not only made the job quicker and easier, but it also meant all work could be inspected in comfort from above.

The engine compartment was good, as was the boot floor and rear arches, so the next job was to strip all the paint using industrial strength paint remover. This messy job completed, a total flat using 240 grit wet and dry, followed by a complete covering of etch primer. Again the rotisserie made the task much easier.

The underside, including the wheel arches, was treated to two good coats of high build primer, a good flat, then a coat of spray stone chip and to finish three coats of Old English White top coat.

Now to start the conversion. I had previously bought a 1960's Ashley hardtop from Bernie Higginson, a MASC member. It is a genuine article with glass windows, as opposed to the Perspex ones in the new tops. Bernie also supplied the Sprite Mk II seats that I wanted. The hardtop was designed to fit an earlier car than mine, so I had to alter the shell immediately behind the doors. I also removed the boot hinge panel and repositioned it further back. This gives a lot more room behind the seats. I created a platform for the hardtop to sit on and bolted the top firmly to the body. I made some neat brackets and bolted the front of the hardtop to the screen. Using a small amount of body filler, I blended the hardtop and body to create a neat finish. The rear panel offered plenty of opportunity for improvement. I removed the centre of the panel and let in the number plate panel from a Mk I Mini boot lid. I also frenched in the flip top fuel filler and a rear mounted spot lamp as a reversing light.

The one piece GRP bonnet came courtesy of Moto Build, who own the rights to reproduce the Ashley products. It fitted well after a little adjustment. I did away with the Triumph Herald type fixings and replaced them with much neater Dzus fasteners. I also purchased a pair of BMW Z3 side vents and along with some nice round MG badges, let them into the bonnet sides. The next modification was to fit three windscreen wipers, as per the American spec. To get the spacing right, I bought an American sales brochure and measured the distance between the wipers and scaled it up to full size. They work well and look really neat.

I fitted larger Wolseley 1500 brake back plates and drums to the rear axle. This is a well recognised upgrade giving improved braking. The original brake and clutch master cylinders were replaced with the very neat Sebring conversion, courtesy

of Brian Wheeler. I also replaced the lever arm shocks with adjustable telescopics. The new rear springs lowered the car by 2 inches. The front suspension was treated to a Frontline Developments telescopic upgrade, also doing away with the lever arm shocks. The new coil springs lowered the suspension by 2 inches to match the rear. The wheels are 14 inch Minilite replicas, filling the arches nicely.



The 1275 cc engine has been reconditioned by PBW in Birmingham. It has a slightly better cam, a Mini Cooper S cylinder head and a 40 DCOE Weber carb. To help breathing, it has a stainless steel three branch manifold and sports exhaust. An aluminium radiator and electric fan look after the cooling.

Front and rear suspension fitted and engine still out, the rolling shell went to MRH Autos Ltd in Lichfield, Staffs, for a full professional respray in Old English White. They prepared and sprayed the car in two pack paint to a superb finish.

On return from the paint shop, the job of fitting the engine and gearbox, bonnet, boot lid and doors took about 4 weeks, working 6 days a week. Inside the car, I selected to use a Frogeye dash, the Mk II Sprite seats and Mk III Sprite door cards, all my favourite choices. They are in green with white piping.

My favourite details? Well, I love the triple wipers and the RWA 267 (round wheel arch) registration.

The full transformation took 3 years to complete, which I thoroughly enjoyed and I am very happy with the end result.

The car is fantastic on the road, even better than I had expected.

Fast forward 6 months and shortly after leaving home a faulty fuel regulator leaked petrol on to

the hot exhaust manifold and set the car on fire. My wife, who was first to detect the smoke in the passenger footwell raised the alarm. We pulled into a side road and leapt out of the car. Within seconds the front of the car was engulfed in flames. We dialled 999 and the fire brigade were on the scene within minutes, but it was too late to save the car. What a disaster, this was not the future I had envisaged for my dream creation.



CAMBRIDGE REBORES LTD

ENGINE RECONDITIONERS

*The Quality You Expect...
...On Time*

OUR SERVICES INCLUDE • Unleaded Conversions • Refacing
Hot Pressure Testing • Reboring & Sleeving • Flywheel Grinding
Con Rod Reconditioning • Line Boring & Honing
Crankshaft Regrinding & Dynamic Balancing

www.cambridge-rebores.co.uk



1 Broads Road Business Park • Burwell • Cambridge CB25 0BT
T: 01638 743 797 E: sales@cambridge-rebores.co.uk

NEC CLASSIC CAR SHOW



Lancaster Insurance Classic Motor Show NEC 2018

At this time of year when the show is over, I seem to start this article in the same way by saying what a great show it has been, and trying to find a different way of saying it is getting more difficult. So at risk of repeating myself, we have had another fantastic show, we now have another 28 new members, and although the number is not as high as it has been in recent years, I do think that the numbers attending the show were down this year. I have not been able to confirm this yet but the crowds did appear to be a bit thinner; this may be due to a hike in ticket prices or it may be due to Brexit.

Either way, we were kept very busy for most of the 3 days by a steady stream of visitors to the stand. We were bombarded with a huge range of questions about our little cars, and I think that we were able to answer the vast majority of them.

This year's stand was in a very good position, not too far from the main entrance to hall 3 and in a central position with lots of people walking past. The only downside was we had a pillar in the middle of the stand. This is the first time for a few years that we had a pillar so I don't think we can complain too much.

As the 60th anniversary of the Sprite comes to a close, the display of cars was chosen as a final celebration and consisted of a Sprite of each mark and a very special Super Sprite prototype 364 EAC, which attracted a large amount of interest from the public and from the press. If you were

not able to make it to the show our chairman Mark Hall made a short video of the cars and posted on the Facebook page. It is worth a look.

A big thank you to all those whose cars were used and were turned out so well to represent the club and not forgetting everyone who came along to help. Without their combined enthusiasm it would make my job so much harder. Also a big thank you to all of you who came to visit us and also drop off your club vouchers; at 56 this was the most we have ever had.

But now, the Practical Classics Classic Car and Restoration Show is on the horizon, 22nd - 23rd March 2019 to be precise and already I have some suggestions for what activities we could undertake at the show, but more of that later. Please put the date in your diaries or IPads.





Finally, a warm welcome to all those who joined MASC at the show, I hope we get to meet again at some point in the future, and happy Christmas and a trouble free new year to everyone.

Alan Pritchett



And the show is over for another year.

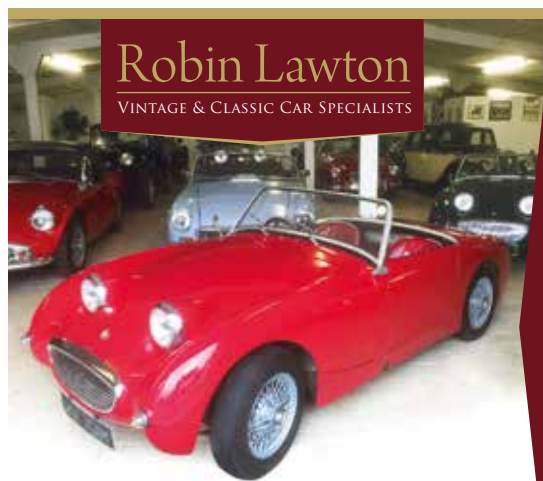

Robin Lawton

VINTAGE & CLASSIC CAR SPECIALISTS

QUALITY SPRITES
AND MIDGETS
ALWAYS WANTED
ESPECIALLY FROGEYE
AND PRE-74 CARS

We specialise in selling quality Vintage & Classic Motor Cars and Spridgets have always been a particular passion.

We are located between Peterfield and Alton in Hampshire, between the A3 & A32 in the beautiful South Downs National Park.



WE OFFER - OUTRIGHT PURCHASE
OR SALE ON COMMISSION

T: 01420 474919 WWW.ROBINLAWTON.COM



'BRAKE' - DOWN AT AIRVAULT



On the third day of our amble toward Angouleme, for the 'Circuit des Remparts' race weekend along the back roads of France on entering the town of Airvault John Clark reported brakes failing on his 1958 Frogeye. Oh well it was lunch time and time for a stop! Was it the enforced braking for the disobedient Huntsman's dog that, ignoring its master's voice command, ran from a field onto the road and into our path earlier that day.

Having found a suitable parking space near refreshment and washing facility from the dark depths of John's Frogeye's boot John brought forth a scissor jack and his 'Rally Pack' (tools and spares). A sandbag was borrowed from where it held a road-sign, against the wind, to act as a wheel chock. The car was raised after inspection showed silicon brake fluid at the base of the offside brake backplate. Wheel removed and brake drum released it was obvious that the double acting slave cylinder was leaking on one side.

John had a spare 'rubber seal' or so he thought. The master cylinder was capped with a bit of plastic carrier bag to stop atmospheric pressure bleeding out the precious brake fluid. We had some silicon brake fluid with us for 'top up' but not large quantities. The slave cylinder piston was released to reveal the defective 'rubber seal' : not of the same design as that carried as a spare by John.

This can be a problem of using various pattern parts so as on many tours we improvised.

The slave piston held its 'rubber seal' piggy back style. The spare was too short giving rise to the concern that it might twist in service as it moved too and fro in its seat or not spread enough. Our first attempt at repair was to try and cut a spacer

from a 'concertina' water hose that normally sits between block and cylinder head. The knife available was not sharp enough to cut a really thin slice. A ham slicer would have been useful but the local Boucherie was closed.

The thickness of our spacer, once fitted, would not allow the sealing rubber, that it 'backed', to collapse enough to fit back into the slave cylinder. We were not concerned that the fluid might react and swell the rubber as John & I are long time users and enthusiasts of inert silicon brake fluid.

A quick re-evaluation and a spacer was cut, still using the not overly sharp pen-knife, from the original worn out rubber seal.

Not wishing to soil the parking space we bled the brake system into a cup disposing of used cup and fluid in a refuse bin.

Some 800 miles later and our improvised seal is still giving good service.

Alan

Kent Rep.

01322-384050
(answerphone - just a brief explanation of query, name and number and I will get back to you)

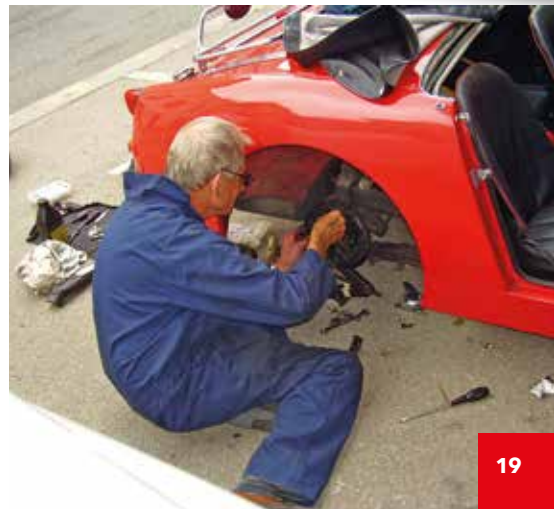

TRIALS AND TRIBULATIONS OF AN IOW SUPERSPRITE



I have travelled many thousands of trouble free miles in my SuperSprite, including several Miglia Tours to Italy, Switzerland, France and Belgium.

My MOT inspection this year revealed some wear in the lower front wishbone swivel joints, resulting in a need to replace before next year.

I know a lot of you have been having problems with replacement wishbone quality but my issues are different and almost unique. My car was constructed by the Frogeye Car Co. on the Isle of Wight who tried to take a more modern route to achieve the suspension geometry we all know and love. Shane Brading (son of FCC boss Keith) re designed the front using available parts and I have the following collection. Uprights and lower wishbones from a front wheel drive Rover Metro, using sealed for life swivel joints. Top wishbones from a Triumph Spitfire and antiroll bar and links from a Spridget. Springing is provided by cleverly mounted coil over shocks using a fabricated lower bracket fixed to the bottom swivel mount bolts. Another fabricated bracket attaches the rollbar links

to the wishbone. All this gives the same geometry with virtually zero maintenance and it looks very much like a Spridget at quick glance.



The worst issue surprisingly was to replace the rollbar droplinks, one of which sheared a bolt even after a good soaking. All the usual suppliers offer these links for around £9 each, but wanting to support a local Kent firm I ordered a pair that arrived promptly. They were obviously 'pattern' in quality and made with the incorrect offset angle. The dealer confessed "some come out different" and offered a refund. Next came a pair from the MG owners club which were equally as bad and returned. Alan Anstead our area rep, circulated my dilemma and several 'white knights' came to my rescue. Brian 'Scotty' Scott, a Kent member who has written in Mascot of his project to involve youngsters in our cars, contacted me from 'Scottys Retro Workshop'. He had a new pair of links to the correct offset and stamped with the correct part numbers 8560LH / 8560RH . I collected them from his Benenden workshop and my car was back on the road the same day. Thanks Scotty and the other 'white knights' We have a great club!

I must just add that Alan A who is the competent owner of my old Myford Super 7, suggested at an early stage that I should make some fully adjustable links by cutting and sleeving. I thought he was simply taking the micky as my lathe sits in pieces on the garage floor following my recent move. However an image pinged into my email of the latest creation from 'Anstead Light Industries ' of a fully adjustable link sleeved and lock nutted! Some people really know how to rub it in!!



ON IMPROVING THE HORN CIRCUIT: PART 1

Various Lucas horns were fitted to Sprites and Midgets throughout production at Abingdon, all possessing an internal resistance of 1-2Ω. At the beginning, two options were offered for the Frogeye: one small high frequency horn (type HF1849) requiring about 6amps or two very impressive 'windtone' horns (type WT618) requiring a massive 24 amps. In both cases a relay really should have been used to protect the primitive horn-push circuit but, in the end, only the Frogeye's twin 'windtone' horns received this treatment.

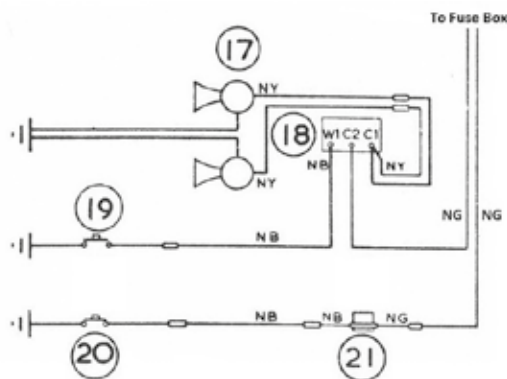

The official circuit diagram for the Frogeye shows two horn options: no relay for a single horn (21) and switch (20) or a Lucas 6RA relay (18) with switch (19) and twin horns (17). No later Sprite or Midget had a horn relay option on offer.

Later cars were not so lucky: except for the luxurious Innocentis, no horn relay was ever specified for them despite the fact that twin 'windtone' horns continued to be listed as optional extras in all the sales brochures. The inevitable result of this apparent petty penny-pinching by BMC's bean counters is that a Spridget's horn circuit is often one of the most fragile parts of its electrical system. How many of us, I wonder, have breathed a silent sigh of relief when our horn behaved itself at its MoT test? And how many

more of us have cursed when the thing failed, even though it had awakened our neighbours two hours earlier? Far too many, I fear.

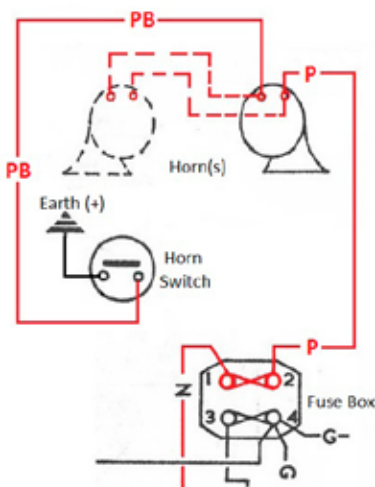

Factory horn circuit: Mk2 Sprite and Mk1 Midget. The 'live' part of the circuit is coloured red. The purple (P) and purple/black trace (PB) wires are both about 6 feet long, each running from the horn(s) in the front valance to near (P) or behind (PB) the dashboard.

If one casts a critical eye upon the horn circuit of any Spridget which does not use a relay, the only really good parts (in my view) are the Lucas horns themselves. For the following reasons the rest of the horn circuit is best described as decidedly dodgy ...

First: as the primitive horn button must make a direct connection to earth¹, most of the horn circuit (from the battery to the horns and back to the horn

1 Any alternative arrangement would require TWO wires serving the horn push assembly in the middle of the steering wheel, two horn pencils and two separate annular brass rings. Aaaahhhhh!!!!

push) is always 'live', a dicey situation that would probably fail modern safety regulations.

Second: the total length of wire serving the horn(s) is twice the length which would be required if the horns were instead earthed at their mounting point(s) - so serious voltage drop is possible, particularly these days when many replica wiring harnesses are constructed with wires much thinner (less sturdy) than original.

Third: the need for a springy flexible wire inside the little 'pencil' or 'horn brush contact' that connects the horn push in the middle of the steering wheel to the 'live' fixed annular brass plate beneath is at odds with the need for it to carry 24 amps. These two requirements are mutually incompatible: the little flexible wire is a fuse-like thing for twin 'windtone' horns. The tiny pencil is often the cause of much frustration, dismay and raised blood pressure.

Fourth: The steering column itself is not a reliable earth point. Plunging down through the dashboard, it is insulated from the body of the car by the padding within the outer (fixed) part of the column and by the padding of its under-dashboard support. An effective earth for the horn(s) therefore depends mostly upon contact lower down between the steering pinion, the steering rack and its supporting

clamps. As the rack and pinion is lubricated with oil, this connection is not exactly first rate, particularly if it has to carry *ca.* 24 amps. In an earlier article² I have already described how an extra short earth wire from the steering rack pinion cover to the adjacent steering rack mounting bracket can improve this vital earth connection. The factory did (I think) install this wire on later cars but it is often missing after major restoration.

In Part 2 we shall see how the four problems described above can all be solved quite easily for less than five quid with one perfectly placed relay, even for later cars where access to the behind-dashboard area is either too difficult or impossible. With current-hungry twin 'windtone' horns or similar, the happy result is only 0.150 amps (150mA) flowing through the horn pencil and a much greater chance of the horn(s) working properly at vital moments (not just at MoT time). The horn is an essential safety item: it should sound reliably, no matter what, every time the button is pushed.

John E. Davies (Member 3443)
jed2@cam.ac.uk

2 MASCOT May 2017, pages 12-13

REGALIA

All available on line, along with other items at:
www.midgetandspriteclub.co.uk



Binders
£6.50



Key fobs
£3.25



Golf umbrellas



Grille badges £21

Window stickers
£1.75



Badge Bar badges now in stock, £21



For one of the last driving events of the year Central members decided to head East and help celebrate the 70th anniversary of Hall's Garage in Bourne, Lincolnshire. Hall's Garage is well known for it's restoration of Midgets and Sprites and even supply their own version of the car, the Tifosi. The drive from the Midlands through Melton Mowbray and the surrounding villages was taken top down in bright sunshine on one of the best days in late October. Arriving, we were met by large crowds and lots of Midgets and Sprites packing the car park and surrounding roads. Andrew Parrott had arrived earlier and been advised to park outside a large blue door near the centre of the main garage. It was only when garage owner Steve Hall announced the main surprise that Andrew's car was engulfed by people as the large blue door was drawn back to reveal the new Tifosi GT car, the highlight of the day. MASC members from all areas had come for the event and it was good to catch up with friends new and old



whilst sitting in the sunshine enjoying fish and chips from the shop directly across the road.



While some members have been enjoying the good weather others have been beavering away in their garages. One such member is Dave Thrussell.

You will remember I told of Dave's plan to restore his Midget a few months ago. Sad to say the shot blasting did not go well. The paint was hard to remove and this caused some damage to the metalwork which has made for extra work that Dave could have done without. However, after a lot of hard work and effort the shell is now primed and painted and is ready to be fitted out. Dave is beginning to sort through the components removed, cleaning and checking before starting the task of putting it all back together. I hope Dave will keep us posted as the build gets underway so we can follow his progress.



One car that doesn't need restoring is that of Elaine Parkes. Elaine's car took pride of place along with five others on the Midget

and Sprite Club stand at the Classic Car Show, NEC, Birmingham. "Gaby" as the car is affectionately known had been given lots of loving attention (and polish) by Elaine's husband Martin. MASC Stand organiser Alan Pritchett had kindly invited Geoff Mears onto the stand on Friday and myself on the Saturday. This gave us both chance to greet Central members who all seemed to be carrying carrier bags of goodies they had purchased at the show. Without doubt the most heard comment on the stand was that the Midget and Sprite Club was a friendly club to be part of. Long may that continue.

Dave Warren
Central MASC
Email to central.masc@live.com



Winter's here and summer all but a faded memory. Now is the time to get all those jobs done we put off during the summer as we couldn't take the cars off the road.

The frog has just had her carbs reconditioned so hopefully all the problems have now been sorted.

Unfortunately, the Mk111 Sprite blew a core plug and cooked the engine so at the moment she is undergoing an engine transplant from 1098 to 1275 re bored to +30, so looking forward to an exciting drive. Prior to that she had a complete restoration, new front wings, front valance, inner & outer sills passenger and drivers floorpans & 2 half rear wings, that is what happens when you just start with a re-spray! I kept the original colour Riviera blue with blue interior, mind you she really does look out of the box now, roll on summer.

We haven't had any club events since November issue of Mascot but hopefully we will have a few breakfast runs subject to weather later this month.

Our Christmas dinner is December 12th 19:00 for 19:30 Court Farm.

Chris Wood 5130





After many weeks of burning the midnight oil, and there is certainly plenty around with Midgets and Sprites, local member Peter Vallins debuted his newly restored bright yellow Frogeye at our October club night. Well done Peter and he tells me that he could not face a third restoration and has now sold the remains of yet another Frogeye!

Our October club night was the first at our new venue, the Charlton Inn and also had another 'first' for us – a speaker. Our club nights are usually very informal, some might say disorganised, so this was a real change for us.

But taking advantage of a little more space at the venue and linked to a charity donation we were making, we welcomed Freya Puttock who told us all about Wessex 4 x 4 Response.

After presenting Freya with a cheque for £500 raised by Dorset Area club members, she talked to us for 20 minutes or so about the role of her organisation. Contrary to the thinking of some, the 4 x 4 Response organisation is not one comprising of members tearing round, and tearing up, the countryside.

Part of a national network and covering three Counties, the Wessex 4 x 4 Response provides emergency logistical support to the emergency

services and local communities. With several hundred members, who are trained and vetted, the ability of the team to support communities at times of need such as severe weather is reassuring.

A few days later I presented a further £500 raised by our members to Kay Bundy the Fundraising Co-ordinator of the Bournemouth Multiple Sclerosis Society at their local centre. Dorset area members Peter Vallins, Roy Kendrick and Dave Hindson kindly brought along their cars which were appreciated by all.

They were kept busy with lots of questions being asked by staff, carers and MS sufferers who came out in cold conditions and showed great interest in our cars. A very rewarding exercise for all involved and it left me with the thought that perhaps we should perhaps repeat this exercise with other organisations where the cars would be of interest.

The year seems to have passed quickly but with my Frogeye again requiring attention I'm sure that I will have a busy winter like many of our members. Festive greetings to all members of MASC and happy motoring in the coming year.

John Gully
Dorset Area Representative.





The main event this month was the Hall's Garage open day, the fantastic summer weather had come to an end, however true to form a warm sunny day popped up in the middle of a less than perfect weather period. Hall's garage is situated opposite the fish and chip shop in the village of Morton, a couple of miles north of Bourne in Lincolnshire (Bourne is famous for its motor racing connection, being the home BRM and for being the place where Pat and I got married). From where I currently live Hall's Garage is just a pleasant 20 mile drive to the north, and a very pleasant topless drive indeed on a warm sunny Saturday. I am still not sure who put this event on the Mascot events page (it wasn't me although being so close to my area it possibly ought to have been), but well done whoever it was as it is always well worth a visit.

I have often said the weather always seems to smile on events that are attended by the East Anglian area (come to think of it, I can't actually

remember using the hood at any of our events) so it stayed hot and sunny all day. There was a good turn out of Spridgets from many different MASC areas with more cars in attendance than last year. Hall's is basically an old-fashioned village garage composed of old brick buildings, that I presume have been added to and extended over the years, and has gradually become a favourite of the classic car fraternity. The sort of place that has workshops with white painted brick walls with a coke stove in the corner and forgotten enamel signs for long lost automotive products still displayed where they have been for decades.

It is a working garage and still caters for the locals, although all the cars in the workshop on the day of the event were classic sports cars. The garage forecourt and adjoining grassed overspill area were soon filled (largely with MASC cars) with some double parked or having to park in the street. For me this event is more about meeting up with people from other areas in a classic friendly atmospheric environment, than it is about actually looking around the garage, although the garage is interesting and the staff very knowledgeable. It was brilliant to see a good number of old friends and well known MASC personalities, I spent a few happy hours doing just that before returning home in the sunshine.

Regarding my impending move to Cornwall and consequent standing down as East Anglian area rep, we discussed succession at the monthly FBI meeting. The current plan is (at least in the short term) for a small group of area stalwarts to cover the role between them, although I believe one person will pop their head above the ramparts and become the official area contact.

Dave Dixon (AKA Red and sometimes blue Leader) e-dave@hotmail.co.uk





Dave finally has the weather to lead his run

The Weather was unusually good when we met one late October Sunday for Dave's afternoon run. Most ventured out with their tops down some in shirt sleeves, what a wonderful summer we have had this year.

The run started at Great Dunmow with eight cars, seven Sprites/Midgets and Diane in her 1971 Fiat 500L, which was being used as 'Noddy', her red Sprite returned to the Garage for some remedial work to the restoration which has taken most of this year – it's a shame to have lost so many 2018 driving opportunities.

Dave borrowed and modified his route from Paul & Helen's abandon September run. What followed was 35 miles of fantastic driving through some beautiful Essex villages on lovely country roads not often covered by our club. We passed through: Thaxted, Radwinter, The Sampfords, Hempstead, Steeple Bumpstead, Finchingfield, Great Barfield and Great Sailing. Seeing three windmills on route and ending the drive at an obligatory Tea shop for refreshments. We were joined here by Tim and his Son David who had been competing in a vintage Land Rover event with David coming a commendable 2nd in his class.

A great time was had by all and it was great that Dave, who generally does the last run on the year was able to complete this year's in style.

The final drive of the year is the infamous 'Santa Run' which will be taking place on the afternoon of Sunday 2nd December and is being organised by Jane & John. At this fiercely competed event everyone is encouraged to come in fancy dress (and we know Jane enjoys dressing up!) with cars decorated in a suitable Christmas theme. Francis has won the 'Best Dressed' car category for the past two years and rumours are he has already prepared this year's creation and it is going to be spectacular.

Our Christmas Dinner is on Friday 7th December at The Bell Boreham, for anyone who has not registered an interest and would like to come please let me know ASAP.

On a very sad note I have to report one of our long standing and active members Graham Prosser passed away in early November. Graham was full of energy, a larger than life character and one of the founding members of the Essex Sprite & Midget club. Earlier this year, innovative as always Graham organised a driving challenge, which was great fun. Our love and thoughts are with his wife Trish and Daughter Kathryn during this terribly difficult time.



Classic Car Show NEC

The Show organising legend that is Alan Pritchett has done it again and delivered a fantastic Classic Car Show three day event at the NEC over the 9th, 10th and 11th of November. To follow up Spridget 60 the theme this year was all about Sprites and Alan had organised examples of Sprites Mk1, 2, 3 and 4 plus a rare Austin Sprite. The star of the show for me however was the unique Healey prototype XQHS Super Sprite. Donald Healey and Leonard Lee, chairman of Coventry Climax, allegedly sketched out the idea over dinner in 1959, the concept being that it would be the sort of small sports car that could be raced at the weekend but was practical enough to drive to the office on the Monday morning. It boasted disc brakes all round, a lightweight alloy body and a 1000cc Coventry Climax engine and was put forward for low volume production but alas it never made it. I absolutely love combination of the "Big Healey" style sculpted side lines combined with the Sebring aerodynamic front end. Just to show that it was a close relation to the Frogeye, of course it has no boot lid!

The Show itself was the biggest yet with thousands of visitors noisily catching up with fellow Classic pals from overseas and opposite ends of the country. At 11am however, without prior announcement, Big Ben struck the eleventh hour



of the 11th month over the NEC PA system marking 100 years since the cessation of the Great War. The two minute silence was observed immaculately by all, which I believe demonstrates the general good calibre of us Classic Car Wallahs.



Tax Invalid

On a less sombre note, Heart of England Dude Les Jeans was looking forward to his 1500 Midget (Bluebell) reaching the milestone age of 40 recently. He did however jump the gun slightly and when he turned up at the Post Office, documents in hand he was turned away as he had to wait until the Road Fund Licence was actually due for renewal. Les retreated temporarily but then at the allotted time set out once more for the Post Office with gusto. This time the Post Office official carefully examined the documents and after a few seconds of consideration, let out a hearty laugh and stated that he couldn't possibly award Les's pride and joy Historic status. Somewhat indignant and crestfallen, Les enquired as to why not. "Because the DVLA have your Midget listed as an Invalid Carriage mate" guffawed the inconsiderate official. Poor old Les has now had to send all of his documents off to the DVLA in the vague hope that they will sort it out and restore the Fine Fifteen Hundred to its deserved status. When I heard of this sorry tale I gave Les a few words of support and suggested that if the DVLA failed to sort out the paperwork, he could always retain the Invalid Carriage status because at least he'd be able to park it anywhere without any problem!

Empathetic Steve



The last day of September gave us perfect weather for driving our 1958 Sprite on a Run superbly organised by Keith Warner. We were able to attend early services at our local churches before setting off to join eight others at Redbourn. The forty mile Run which was led by Keith, who also gave us clear directions on paper, took us unerring to Winslow where another car joined, then on to the Milton Keynes Museum in time for lunch in its little cafe.

Afterwards we paid just £7 each to go in the Museum, which also gave us free entry for the rest of the year, and was well worth it. Despite a devastating fire in 1998 volunteers had raised money for rebuilding, filling it with treasures from the past, many of which had been donated. On entering the house, whose rooms were crammed full of a great number of objects once used by the Victorians, we went through into the old street with shops of every kind to be found in years gone by. It was fascinating and well worth the visit. Thank you so much Keith for organising it.

Pat & Zara Kimber

Potential events planned for 2019:

Sunday, 7 April - Bromyard Speed Festival, Malvern

Sunday, 14 April - MG/Healey Day at Brooklands Museum, Surrey

Sunday, 19 May - Hambleton Classic Car Meet, Nr Marlow, Bucks

Saturday, 20 July - Festival of the Unexceptional, Stowe School, Nr Silverstone

Sunday, 4 August, Ashlyn Hall Classic Car Show, Nr Berkhamsted

Sunday, 18 August - Cars & Kites, Hunstanton, Norfolk

SPRIDGET
The Story of the Austin Healey Sprite & MG Midget

The Austin Healey Sprite was launched in 1958 to fill the gap in the market for an affordable sports car which had been left when the original MG Midget went out of production. Now being their final 1961 MG version of the Sprite was called 'Midget', so the Sprite and Midget are referred to as 'Spridget' and the same basic car would remain in production into 1979.

This documentary covers the complete history of these cars with input from some of the men who were at the Healey Motor Company when the car was first conceived and in production. Also, the 'wreck' racing programme is featured with top Healey race driver, Clive Baker, detailing some of the Sprite's history at Le Mans, Sebring and other historic circuits around the world.

Terry Horner is the Midget & Sprite Club founder and Spridget historian and he talks us through the history of the cars from their early beginnings to the last MG Midget powered by the Triumph 1300cc engine. A controversial car at the time, but the Triumph engine kept the cars on sale in the vital American market which accounted for around 80% of all British sports car sales.

Extras are the extended interview with Clive Baker and 'South-West Spridgets' where a collection of Spridgets gather at Coldharbour Mill in Devon.

Start-up time approximately 90 minutes including extras
 Screen ratio: 16:9 panoramic widescreen Audio: DTS Digital 2.0
 © 2018 Home Counties
 No Region Code Applied
 U.J. Clancy 2018

SPRIDGET
The Story of the Austin Healey Sprite & MG Midget

SPRIDGET
THE STORY OF THE AUSTIN HEALEY
SPRITE & MG MIDGET

DVD VIDEO

ICLANCY

www.burtonhub.co.uk



East Kent October meeting at The Crown Inn Sarre

With a promise of a good turn out this weekend but with the threat of Atlantic storms crossing the Country to spoil it, it was some relief that the day dawned bright and sunny in East Kent and my Frog emerged from its home for the second day running. Beautiful days in Kent this year.

Carole and I arrived early and found a nice Midget already sitting on the forecourt which we had met in passing the day before with the usual joyful waving from all parties at meeting another Classic, incidentally the only one that day. The owners, members Mark and Caroline Jackson had travelled all the way from Richmond west of London to lunch with us (well actually they were visiting family in the area). It was good to see them and hopefully they will be back. Not to be outdone on the mileage stakes though our regulars Richard and Linda Beer had flown in from Croatia such is the draw of a Crown Inn lunch. In all a total of 20 members with five real cars attended a colourful line on the forecourt so the tables were full today. Dave Chalk was excused for leaving his IOWight at home as he

recovered from medical attention to his hand. His height is a limiting feature in a Sprite but a splinted hand was the final straw.

Not sure if we have done repairs on the pub forecourt before but Mike had done the last 30 miles of his journey with a misfire. So lunch done it was bonnet up, changing coils, checking connection and finally isolating the problem to a faulty newly acquired electronic dizzy. Replacement with the original restored it to perfect running and the faulty item has I understand been replaced by the supplier.



Phil Manship reported on his acquisition of a 1930's Austin 7 Opal which he and Dave finally collected from East Anglia earlier that week. I witnessed the offloading from the back of a van. Have you ever tried rolling a car down scaffolding planks where steering is negated by three tyres which basically retained air for less than 3 minutes? Nerve wracking to say the least. Anyway the little car is now sitting alongside his Midget in the garage and the temptation to start work on it has been too much and he has started. Best of luck Phil.

We are getting closer to Christmas and the Dinner table is filling nicely with all rooms at the Inn now taken. Accommodation now only available in the stable with some livestock.

John Clark
East Kent Co-ordinator

An evening of Rock & Roll - Thursday 25th October

On a dark October night in Tunbridge Wells, 22 of us decided to leave our cars in the garage and creep out for a Rock 'n' Roll night out on our own. A nice meal in Carluccios followed by an extravaganza of 50's and 60's Rock 'n' Roll music some of us had sore throats on the drive home due to too much cheering and singing. I know it was selfish leaving our cars behind but we comforted each other in the knowledge that this was their era. A brilliant and entertaining evening out.

Richard Bowles

(Thank you for organising it goes to Richard. I can confirm that it was a brilliant night out - AA)



West Kent Meet on Sunday 28th

Rain, Rain, go away, don't come back until another day! But no one was listening. The sky did brighten and the rain did stop. for a while but the Rainmaster was only teasing: luring but two Midgets into its clutches. One was especially bold: that of Steve & Kath Everest who braved the weather coming from sunny Sussex just to get rained upon in the latter stage of their journey. Fortunately Steve fitted the hardtop yesterday. Some Kent members took a rain check but we still mustered a goodly number.

Talk of engine rebuilds and conversions as is the norm. We look forward to seeing Darren's E-Type Jaguar restoration on a drier day. Gary Puxty showed pictures of his testing of his mount for the forthcoming 'Emancipation Run' on the 4th November when the 'Old Crocks' travel from London to Brighton. For my part I will be at a WW1 Commemoration on that day. Gary's mount is to be a 1900 De Dion Boughton which is expected to achieve 8mph average. Take any car to the Dartford Tunnel and you should be lucky to achieve that speed. He will probably see Steve and Kath at the start, in Hyde Park, as they marshal the event.

A new member was signed up too.

Asked about the Daks over Normandy tour next June I had to say that no more applications can be accepted.

However plans are progressing for the Alpine Miglia Tour 2019 provisionally 28/8 - 9/9 next year. The outline so far is to travel through Belgium visiting Waterloo, passing via the Menin Gate Monument, & Bastogne Museums. Onward into France for the Mosel & Maginot Line. Germany for the Dornier Museum. Austria for a private Rolls Royce Museum then Switzerland for the Autobau Museum & Emil Frey Museum whilst experiencing the Alpine roads. Returning through France over its eastern ranges to Verdun and on to Dieppe.

An entry list has been started with Peter Wilkinson quick 'off the blocks'.

His son Oliver and Georges Guggenheim are doing a sterling job with their plans for the Swiss segment of the Tour.

Too wet outside, with the darkest of clouds looming, it was no day for 'kicking tyres' in the car park that is as if we had many tyres to kick.

Alan Instead
Kent rep.
**01322-384050 (answer-phone for accuracy -
brevity - speed)**



Well!! here we are again, another busy month in the North West!!! A few of our members attended the MASC AGM held at the Gaydon Motor Museum. We just want to say a very BIG thank you to all the committee members for the hard work they do as volunteers which keeps the club on a very healthy footing including the numbers of new members growing and also keeping the club, financially secure especially this year with the organizing of Spridget60. We all enjoyed seeing the refurbished Museum, well the part of it we had time to see. We must return to finish our tour sometime.

On the 28th of October we had our annual Halloween Run. This is where we dress in attire fitting the occasion. Witches, Draculars, there was a couple of Grim Reapers, Maleficant and other scary looking creatures!!! We met up for coffee and may be a nice "Bloody Mary" for those not driving!!!!!!!!!!!!, before leaving to drive a route of about 75miles in an attempt to bring a smile of surprise and horror to the faces of any locals in the towns & villages we pass through or stop at!! Finally ending up in a pub for a late lunch ,which we all enjoyed very much!!! and this year was no exception with a good turnout and great weather to match, and so we had a fantastic day, which gave us much to talk about afterwards!!!!. That's about it car run wise for this year, as we will be bedding them down and doing any jobs that may need doing and looking forward to next years There are quite a few of us already booked to go to Angouleme for Le Circuit Des Remparts in France , which starts on September 2019 for a 14 day holiday, sailing from Portsmouth to St-Malo, planning a route and booking hotels is well on it's way, that's if the French still allow our cars on it's roads after Brexit!!!

Our final event this year will be our Christmas Lunch meeting on the 9th December, we have celebrated in this way for a few years now, and it works very well, as "uup-ear int North"!!!! we never know what the weather is going to do!!!!. Anyway another good year has been had by all our Spridgeteers, it's great to be a member of such a wonderful club, its more like of being a member a large family.

Happy Motoring or Repairing !!!!
Shelley and Neil North West Area Reps.





The October Club night, is Quiz night when we have a volunteer to devise the questions. This year it was Steve and Pauline Keil's turn!!! They came up with a plot to confound us all with an array of questions with multiple answers for each one, in the hope that this year some of us would be successful in getting a few answers right !! We had a winning group headed by Anne and Glenn Clarke, Well done them !! and we also had an enthusiastic volunteer for 2019 by the name of Matthew Lomas A big Thank You.



The world's leading
Austin Healey
parts supplier!



www.ahead4healeys.co.uk

Tel. 0044 (0)1788 565 000

Fax. 0044 (0)1788 565 001

info@ahead4healeys.co.uk



81 Somers Rd, Rugby, Warwickshire, CV22 7DG, UK

Mike Authers Classics
Specialist in Chrome bumper MG Midgets and Sprites.



**WANTED URGENTLY
MIDGETS AND SPRITES**
Excellent prices paid for Frogeyes, Original or
IOW
In any condition



Up to £8,000 paid for Midgets
and £17,000 for Sprites

Tel Mike on 07703 465224

Or mike@mgmidgets.com

Specialist Car Insurance

Adrian Flux know how much you love your Midget or Sprite, that's why we are dedicated to finding you a policy, tailor-made to your own personal requirements and driving history. Call us today for a free, no obligation quote.

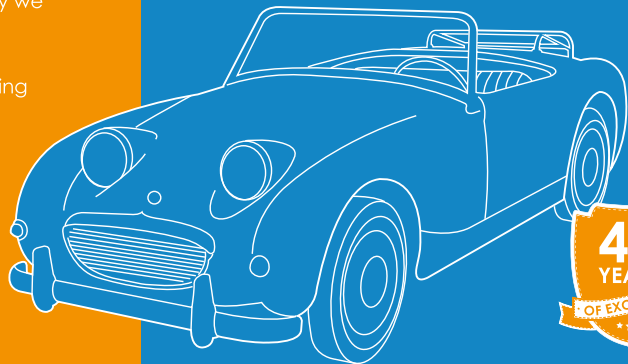

0800 916 1288
adrianflux.co.uk

Authorised and regulated by the Financial Conduct Authority

YOUR PRIDE AND JOY

Benefits available can include:

- FREE Legal Cover
- Agreed Value
- Laid-up Cover
- Limited Mileage Discounts
- Breakdown Cover
- Club Member Discounts



Well, it is that time of year and let me start the report by wishing all M.A.S.C. members a Happy Christmas and a Guid New Year! I hope Santa is kind to you all and brings you plenty of spridgety things. Personally, I make out a Santa's list. That may seem a bit selfish, but it avoids duplication and lets Mrs Santa tell the nephews and nieces what I would like when they ask what present to get me for Christmas. I must be a nightmare, as at my age I have got most of the things I need - or if I see something I would like I just go out and buy it. Although, I would quite like to see a lathe coming down the chimney this year.

A couple of weeks ago I received a phone call from Stuart Watson, the membership secretary, advising me that a chap from Edinburgh had been in touch with him about some spares he wanted to sell on. These included four 1275cc engines to suit the sprite/midget! I immediately contacted the guy and a deal was struck, not only for the engines but for a load of Morris Minor parts. I contacted the members of the club requesting help and Allan Clarke not only said he would be willing to help but he had a Transit style van. So along with a friend who had a trailer, the three of us set off early one Saturday morning for Edinburgh.

The elephant in the room, so to speak was the chap lives three stories up in a tenement flat with the spares being in an attic. As none of us are in the flush

of youth we were not looking forward to the constant traipsing up and down 3 flights of stairs. Allan came to the rescue with an idea, as we had brought some rubble buckets and a fair length of rope we just filled the buckets and lowered them down, job done!!

The next problem was where to put all these spares, the garage is packed to capacity - so I decided to invest in one of these mobile garages and store all the parts bar the engines. Now all that remains is to sift through it all and decide what I will keep and what I will sell on ebay.

Other things have not been neglected, however. The bubble car is now stripped down to its component parts and the chassis is ready for cleaning and/ blasting. The engine, gearbox and transmission will be checked and worked on over the winter months. Hopefully work will restart on the Rusty One, once I have rearranged the garage again.

I am writing this as my wife and I await the taxi to the station to go to the Classic Car Show at Birmingham, so I am looking forward to a good weekend.

Well, just returned from Birmingham and once more the Midget & Sprite stand was superb, I especially found the Healey XQHS Super Sprite Prototype very interesting. I am sure more on the show will be reported in the magazine in greater detail.

Graham



Whilst Valerie and I have also been otherwise occupied others have been attending various events including the Autumn Classic race day at Castle Coombe, a Sprint meeting at the Clay Pigeon Raceway near Dorchester, and the annual Motocross meeting on the beach at Weymouth. I was asked to supply marshals for one stage of a new event in October, the Lombard Rally Bath, a 'touring assembly' rally for 1970s/80s rally cars to remember the glorious days of the Lombard RAC Rally visiting 4 of the iconic venues of the day. These were Longleat, Cricket St. Thomas, Chard, Wiscombe Park hillclimb and Porlock Hill. This was a real treat for those of us who were there during that era and to see once again the cars and several of the drivers from the era including Stig Blomqvist, DavidLlewelin, Jimmy Macrae, Louise Aitken-Walker and Rosemary Smith. As for the cars most of the iconic makes were represented, many being ex. works competition cars including Escorts, Lancias, Rover SD1, Audi Quattros, Opel Mantas, Minis, Sierra Cosworths, Chevettas, Saabs and TR7 V8s, but sadly no whaling Metro 6R4!



Once the 1st competitors arrived at our venue, Cricket St. Thomas, it was pretty much full on with a 30sec. interval between each, apart from a couple of breaks for the track to be cleared of sheep and cattle! The viewing conditions were perfect with full-on warm sunshine and excellent vantage points along the route out of the park. From Cricket St.Thomas the competitors headed for Wiscombe Park where Jerry Shepperd was waiting with the recovery vehicle, but thankfully not required.



With another year coming to an end it is time to reflect on the past one and for Valerie on the last 5 years as Area rep. as she hands over the reins in the new year. Who will take on this role? Watch this space. The current area membership has declined slightly in the last few months with fewer active members and some not renewing their membership; hopefully it will pick up again in the spring.

As for 2018 the area had 38 active members who between them attended 24 classic shows, 10 meetings (mainly monthly for a meal), and participated in 10 local runs. In addition the few more adventurers amongst us ventured to Le Mans, other parts of France and the Isle of White for holidays.

That's it from me so safe and happy Spridgeting in 2019.

Peter Young



DEAR MASCOT...

DEAR NEIL

I'm fairly sure that John's hardtop (November 2018 letters page) is a Pride and Clarke hardtop. My father had one on his frogeye in the early 60's. There are a number of images of P & C hardtops on the internet. It looks like there were two versions, one with a raised V shaped moulding through the centre which could form a vent at the rear if required, and the other with a smooth curved top.

From the photo, John's may be the latter.

What is distinctive to both is the rear window which it seems gave rise to them being nicknamed 'Dan Dare hardtops' because of the similarity in shape to the famous Eagle comic character's space helmet.

Pride and Clarke were a London company, now sadly no longer in existence, who flourished particularly in the 1960s and traded in motorcycles and car and motorcycle accessories.

Hope that's of help.

REGARDS

RAY PATTENDEN

Member 5404

HELLO NEIL

Attached is a picture of my Midget on stands with a non-working clutch. I have replaced the Slave and Master Cylinders which has not cured the problem. However, things have moved on since then as I have purchased a Datsun 5 Speed Gearbox that I plan to fit in the car. It has been removed from a Frogeye and came with some modified parts - propshaft, clutch, etc, so I should have most of the parts I need. I know there are cars in the Club with this gearbox fitted so would be keen to hear from anyone who has done this conversion with any tips and advice that may be useful when I do mine! - Keith Warner, 07800 875835, mrkwarner@hotmail.com.

Keep up the good work - see you at the NEC

BEST WISHES,

KEITH & ANN



DEAR MASCOT

Following us supplying some of your members we thought other club members might be interested in our LED lights.

We would be happy to provide a discount for the club. We offer club discounts at 5% including free UK first class postage. This can be obtained by either using this link: <https://www.classicarleds.co.uk/discount/mAscOt18> or entering mAscOt18 at checkout. It is case sensitive and allows us to track sales through the club.

Classic Car LEDs

0800 246 5678

www.classicarleds.co.uk

**6, 12 & 24 Volt LEDs, Flasher
Relays & ancillaries for Classic &
Modern Cars, Commercial
Vehicles, Motorcycles &
Recreational Vehicles.
Available in Negative & Positive
Earth**

THE WHO, THE WHAT & THE WHERE OF THE MIDGET & SPRITE CLUB

COMMITTEE

CHAIRMAN
GENERAL SECRETARY
TREASURER
EDITOR

AREA REP'S DELEGATE
MEMBERSHIP

GENERAL MEMBER

YOUNG PERSONS REP
FACEBOOK COORDINATOR
MARKETING OFFICER

Mark Hall, T: 01296 660103 E: chairman@midgetandspriteclub.co.uk
Glyn Polly, T: 07544 302 575 E: glyn.polly@gmail.com
David King, T: 01453 544202 E: djs.king46@gmail.com
Neil Thomas, T: 07891 684435
E: editor@midgetandspriteclub.co.uk
John Collins, E: green_mx5@hotmail.com
Stuart Watson, "Staddlestones", Thicknall Lane, Clent, Stourbridge, West Midlands. DY9 0HX.
T: 01562 883076 E: membership@midgetandspriteclub.co.uk
Alan Pritchett, T: 07720 238810 E: a.pritchett@btinternet.com
Gary Lazarus, E: garyfrogeye@gmail.com T: 020 7700 5696
Anthony Cutler, E: anthony.cutler@btinternet.com
Richard Weaver, E: fsam1983@hotmail.com
Liam Murphy, E: biddysingh@gmail.com
Richard Wharmby, T: 07814 764546 E: r.wharmby10@virginmedia.com
Clare Nedin, marketing@midgetandspriteclub.co.uk

OFFICERS

CLUB ARCHIVIST &
TECHNICAL DOCUMENTATION
MEMBERS ADVERTISING
CAR REGISTERS
SPRITES & MIDGETS
(EXCEPT MK1 SPRITES)
SPRITES MK1
REGALIA OFFICER

TECHNICAL ADVISOR
WEBMASTER
TRADE ADVERTISING
ENQUIRIES

Terry Horler, 63 Littledean, Yate, Bristol, BS37 8UQ. T: 01454 881770
E: rebelwithasprite@hotmail.com
Alan Lo, E: alan@mobuzzing.net T: 0117 9572617 Mob: 07474 343643

Stuart Watson, E: stuart@thewatsonz.com T: 01562 883 076

Gary Lazarus, garyfrogeye@gmail.com T: 020 7700 5696
Mike Grout, 55 Park Road, Spixworth, Norwich, NR10 3PJ. T: 01603 890211
E: miketg54@hotmail.com
Mark Boldry, E: mark26r@hotmail.com
Mike Bennett, webmaster@midgetandspriteclub.co.uk T: 01925 727479
Gary Lazarus, garyfrogeye@gmail.com T: 020 7700 5696
E: enquiries@midgetandspriteclub.co.uk / alan.anstead@btopenworld.com

AREA REPRESENTATIVES

BRISTOL
CENTRAL
DEVON
DORSET
EAST ANGLIA
ESSEX
HAMPSHIRE
HEART OF ENGLAND
HOME COUNTIES
NORTH WEST
KENT
LINCOLNSHIRE
LONDON
NORTH WEST
NOTTS/DERBY
NORTH NOTTS
& SOUTH YORKs
OXFORD
SCOTLAND
SOMERSET
SOUTH WEST WALES
SURREY
SUSSEX
WILTSHIRE
YORKSHIRE

Terry Horler, T: 01454 881770 E: rebelwithasprite@hotmail.com
Dave Warren, T: 07831 101850 E: central.masc@live.com
Michael Ellis, T: 07414 279074 E: michael_ellis@live.co.uk
John Gully, T: 07876 334949 email john.gully@btinternet.com
David Dixon, T: 01733 222810 E: e-dave@hotmail.co.uk
Gary Knights, T: 01376 562172 Mob: 07932 077305 E: gknights@live.co.uk
Terry Langridge, T: 01252 626063 E: friendlyfolk@midgetandsprite-hampshire.info
Steve Newton, E: newton-gemini@sky.com
Mark Hall, T: 01296 660103 E: markdhall@aol.com

Alan Anstead, T: 01322 384050 E: alan.anstead@btopenworld.com
Currently vacant
Gary Lazarus, T: 020 7700 5696 E: garyfrogeye@gmail.com
Neil McLeod, T: 01772 466648 Mob: 07921 089 680 E: neil_mcleod2@outlook.com
Ian Cooke, T: 0115 938 3838 E: ilcooke@btinternet.com
John Austerfield, T: 07778 636070 E: austerfield.07@btinternet.com

Grahame Gibbins, T: 01235 530456 E: grahame_gibbins@hotmail.com
Graham Smith, T: 0141 954 8276 E: smith.grahamf@yahoo.co.uk
Valerie Young, T: 01460 391431 E: petyeryoung81@aol.com
David Hill, T: 01239 811307 E: david@hill.be
Mike Gorman, T: 01737-552256 E: gorman698@btinternet.com
Chris Harding, T: 01342 718860 E: harding.cm@btinternet.com
Andy Cross, T: 01225 743554 E: andyspeedbox@gmail.com
Rob Armstrong, T: 07889 090411 E: mascyorkshire@gmail.com



ALSO SEE THE CLUB NIGHTS SECTION FOR NEW AREAS AND CONTACTS

Compiled by Neil Thomas. Please advise me of any changes, errors etc.

MEMBERSHIP RENEWAL:

If you experience 'MASCOT' problems upon renewal, please contact the membership secretary or the treasurer straight away.

CLUB NIGHTS



- 1st Saturday **YORKSHIRE AREA.** Now meet at Chequers Pub in Bilton in Ainsty (which is just to the West of York) on the third Thursday evening of every month from around 7PM – more information at <http://yorkshiremasc.blogspot.com>
- 1st Tuesday **ESSEX AREA.** Now meet at The Green Man, Green Man Lane, Kelvedon Road, Little Braxted, Essex CM8 3LB. For further details contact Gary Knight, Tel: 01376 562172 Mob: 07932 077305 email: gknights@live.co.uk
- 1st Wednesday **CENTRAL AREA.** Now meet each month 8.30pm onwards at the Tame Otter, Lichfield Road, Hopwas, Tamworth, B78 3AF, 8.30 pm onwards Contact: Dave Warren, Tel: 07831 101850. Email: central.masc@live.com
- 1st Wednesday **OXFORD AREA.** Meet at the Blackhorse Pub, Gozzards Ford, Nr Abingdon. 7pm for those eating or 8pm for those not. Contact Grahame Gibbins at grahame_gibbins@hotmail.com
- 2nd Tuesday **LONDON AREA (CONGESTION ZONE).** Meet at The Ace Cafe at 7:30pm together with the Classic Cars Magazine night. Details: Gary Lazarus on 020 7700 5696 garyfrogeye@gmail.com
- 2nd Wednesday **DEVON AREA.** Meet at Court Farm, Abbotskerswell, TQ125 NY Devon. 7.30pm Michael Ellis Michael_Ellis@live.co.uk and telephone: 07414 279074
- 2nd Wednesday **HEART OF ENGLAND.** All welcome at the Green Dragon, Sambourne, Redditch B96 6NU for 8.30 start. To check “what’s on” please email Steve Newton on newton-gemini@sky.com
- 2nd Wednesday **NORTH WEST AREA.** Meet at The Kilton, turn off M6 at Jct 20 onto A50 towards Macclesfield. Pub 4 miles on left. Please note new venue. Neil McLeod email neil_mcleod2@outlook.com Tel 01772 466648 Mobile 07921 089680
- 2nd Wednesday **BRISTOL AREA** will meet at Wishing Well, Wapley Road, Codrington, Bristol BS37 6RY. From 8.00pm – or earlier for a Curry enjoyed in peace! Contact Terry Horler 01454 881770 rebelwithasprite@hotmail.com
- 2nd Thursday **NOTTS/DERBY BORDER AREA.** The Hunters Arms at Kilburn, DE56 0LU (just off the A38) from 7.30. Venues may change through the summer months for country runs. Ian Cooke 0115 938 3838 ilcooke@btinternet.com
- 2nd Thursday **EAST ANGLIAN AREA.** Previously the Cambridgeshire Area meet at The Ferry Boat, at Holywell, 8pm
- 2nd Sunday **EAST KENT GROUP.** Meet at the Crown Inn, Sarre, CT7 0LF from 12.30hrs Contact Area Rep alan. anstead@btopenworld.com or John Clark group co-ordinator jrclark@sky.com
- 3rd Tuesday **SCOTLAND.** Meet at Houstoun House Hotel, Broxburn, EH52 6JS. Meetings start at 7.30pm. Graham Smith 0141 954 8276 email: smith.grahamf@yahoo.com
- 3rd Tuesday **SURREY.** Meet at The Blue Ball, Deans Lane, Walton-on-the-Hill, Tadworth Surrey KT20 7UE. 7.30pm onwards. Contact Mike Gorman, gorman698@btinternet.com Tel: 01737 552256
- 3rd Sunday **NORTH NOTTS & SOUTH YORKS GROUP** meeting is from 10am. The Courtyard Tea Room, Womersley, north of Doncaster DN6 9BH. Contact: John Austerfield austerfield.07@btinternet.com 07778 636070
- 4th Monday **DORSET.** New Venue: Charlton Inn, Bournemouth Road, Charlton Marshall, Blandford Forum, Dorset DT11 9NH about 7.30pm
- 4th Thursday **SUSSEX.** Meet at Bolney Stage, Bolney, RH17 5RL from 19:00.
- 4th Thursday **HAMPSHIRE.** Meets at Lasham Gliding Club, The Avenue, Alton, GU34 5SS. Please ring Terry or Harriet Langridge on 01252 626063 for details.
- 4th Sunday **KENT AREA.** Back at The Angel, Addington Green, Kent until further notice. Contact Alan Anstead enquiries@midgetandspriteclub.com
- Last Monday **WILTSHIRE.** Meet at The Barge Inn, Seend, Nr. Devizes, about 7pm. Contact Andy Cross on 01225 743554 or email andyspeedbox@gmail.com
- Last Wednesday **HOME COUNTIES NORTH WEST** for members in Herts, Beds, Bucks, Berks, N. London or anyone interested! Meet at the Chequers Inn, Redbourn, AL3 7AD from 6:30pm. Please contact Mike or Sue Gahan on email mike@mgahan.demon.co.uk or on 07850 488636.
- Last Thursday. **SOMERSET AREA.** Non-regular and occasional meetings and runs arranged throughout the year. Please contact Valerie Young on 01460 391431 for further information. We may not always be there, especially in the Summer!
- Northern Ireland robertholmes25@hotmail.com. If enough interest, will arrange a meeting.
- South West Wales Non-regular and occasional meetings and runs arranged throughout the summer months. Please contact David Hill on 01239 811307 or email: david@hill.be

MARKET PLACE

FOR SALE - 1971 MG Midget. Ex standard class MGCC Halfords Midget Challenge car with 6 months MOT, new tyres, GRP front wings, & bonnet with very good Tahiti blue paint finish. Car has always been garaged & driven in dry weather. Would make good track day car, fast road, or hill climb car. Modifications to include, Longman polished & ported head, Rally cam, roll bar, & lowered suspension. £4,500 ONO. Contact Mark on 07999 082842. (South Devon area).



FOR SALE - x4 wide wheels (NOT BANDED) which may(?) be suitable for a racing Spridget. Markings stamped on the inside rim read: RSO 1440 5 1/2 x 13 TR 'Dunlop' 'Made in England'. £200 ono. Located Ely Cambs. Contact: Ian 01353-662485



FOR SALE - x4 set Rostyle wheels steel 13" x 4 1/2" including chrome wheel trims, good standard finish, from Midget 1500 £70. Buyer collect, Tony (Notts, Derbys). 01159323434 evenings.

FOR SALE - a pair of D-section headrests in very good condition. £25. Call Gary Reeves on 07803 833089.





Est
1969

HARDY ENGINEERING

THE TRANSMISSION SPECIALIST

- > ALL BMC GEARBOXES, DIFFS AND OVERDRIVES SUPPLIED OR FITTED
- > CUSTOMERS OWN UNITS REPAIRED
- > STRAIGHT CUT GEARS AND LSD'S IN STOCK
- > CLUTCH REPLACEMENTS

We supply, repair and fit gearboxes for all types of Classic cars, whether they are manual or automatic. We will diagnose and repair your own unit, offering great value on replacing damaged gearboxes with fully reconditioned ones. We have an ample stock of spare parts at our workshop in Leatherhead, so we can usually overhaul your transmission unit or differential within a few days.

Established in 1969 our gearbox specialist repair technicians have over 120 combined years of experience in gearbox repair, differential repair and reconditioned gearboxes.



T: 01372 378927 • 268 Kingston Road • Leatherhead • Surrey • KT22 7QA

www.hardyengineering.co.uk

Frogeye Spares

“Knowledge, Expertise & Passion”



The Manufacturer of Wheeler & Davies Frogeye Bodyshells

**Virtually EVERYTHING in stock
to build a complete Frogeye!**

Specialising in new & used parts, complete
new body shells, servicing & restoration
of Austin-Healey ‘Frogeye’ Sprites.

**For all your Austin-Healey Sprite needs, look no
further for friendly service and competitive prices!**

Call the experts today on
+44 (0)1204 604 017

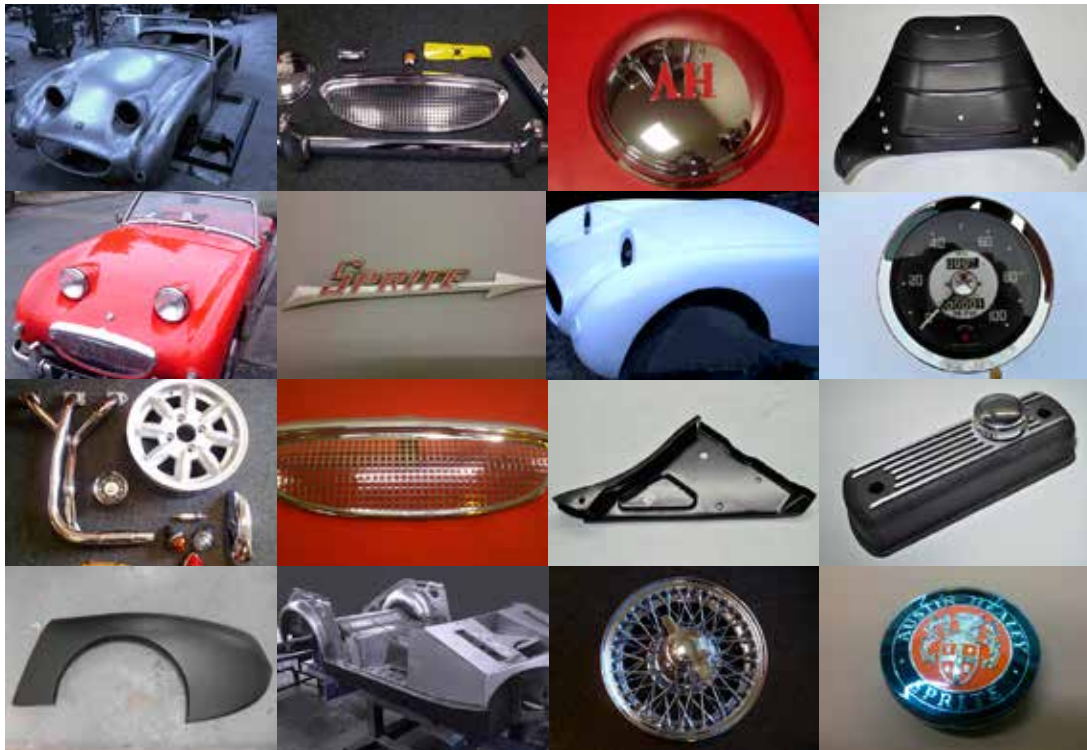

Visit www.frogeyespares.co.uk or email enquiries@frogeyespares.co.uk