

MASCOT

THE MAGAZINE OF THE MIDGET & SPRITE CLUB

ISSUE 406 JANUARY 2018

£3

FBHVC update on VHI



EXPERIENCED THIS?
A SHOCKING SITUATION

**195BHP SPRIDGET
ANYONE?**

ALSO IN THIS ISSUE: CARS AND PARTS FOR SALE • ALPINE MIGLIA TOUR 2017 • FRIENDS REUNITED

**Specialist vehicle
insurance from
people who share
your passion.**



rhspecialistinsurance.co.uk

0333 043 3911



From iconic models to future classics –
we've been providing specialist vehicle
insurance for over 40 years.

WELCOME

TO THE JANUARY
EDITION OF
MASCOT

NEIL
THOMAS

editor@midgetandspriteclub.co.uk



I'm very excited this month. Not only is it the start of a New Year, but we have a new look magazine too.

The intention has been to make it appear a little more up to date but without losing its essential club feel. Thanks go to member Andy Barrass for the design work and of course to Quorum, our publishers. I do hope you like the new look.

2018 is going to be a fantastic year for MASC with so much going on throughout the coming year with the 60th anniversary being a key part of it. Also bear in mind the discount offers available for early bird ticket purchases for both the Practical Classics Restoration Show and the Silverstone Classic.

I also have something rather special lined up for you, beginning in our February issue. A profile and interview with the iconic John Sprinzel together with some rather special photographs. I am certain you will like it. John is an avid member of our club and loves reading MASCOT. We are very privileged to have him on board.

Our membership secretary, Stuart Watson has been in touch with me to report that it was agreed by the MASC Committee at the meeting on the day of the AGM, that the subs for members who pay by Direct Debit would be reduced by a further £1.00. This makes the Direct Debit payments a total of £2.00 less than the normal subs, so now being £25.50 for a single member and £27.00 for joint membership. This reflects the lower cost and effort to the club of receiving payments through Direct Debit. If you would like to take advantage of this reduction please sign up for Direct Debit using the link available to you on your renewal e-mail which you will receive when your annual subs become due. I am sure that you will agree with me when I say the membership fee really is superb value for money.

Lastly, don't forget to use our social media. Our Facebook site is very active and our new Instagram site is in the pipeline.

May I wish you and your families a very Happy New Year. Neil



COVER IMAGE:
Andy and Jeff Barrass's Frogeye giving the Minis a run for their money at the MK1 Performance Conversions Track Day, Blyton Park.

The statements and opinions expressed in each and every issue of Mascot are not necessarily the considered views of the Midget and Sprite Club. The views expressed by the editorial contributors, letter writers and advertisers are their own and do not necessarily reflect the view of the Club. The Midget and Sprite Club accepts no responsibility for the results of following contributor's advice, nor does it necessarily endorse the services or products offered by advertisers.

THE DEADLINE FOR ARTICLES AND REPORTS TO BE INCLUDED IN **FEBRUARY'S** EDITION OF MASCOT IS...

**FRIDAY 12TH
OF JANUARY**

CHAIRMAN'S THOUGHTS 2018



As I sit writing this on a grey Wednesday afternoon in December, watching the rain washing away the snow, I am cheering myself up thinking about the Midget and Sprite Club in 2017 and also the year to come. It promises to be quite a year!

2017 has been a good year for the club. Our membership has grown again, which is great for the future of the club, and importantly the club is financially sound. However, what the club is really all about is enjoying our cars with like-minded enthusiasts and we have done lots of that.

The club has been at two multi day shows this year, the Donnington Historic Festival and the Silverstone Classic. Both are popular events with members from across the country meeting up and getting to know each other. Plus the two NEC shows, the Restoration in March and the Classic in November. Both are a great shop window for the club and this year we signed up around 80 new members at the shows. Area groups are the backbone of the club always running a wide range of events and activities; helping to keep all members involved and active. If you haven't been to an area event this year then why not make it your resolution to join one in 2018.

I started 2017 with an appeal for a new editor for Mascot and I am very pleased that Neil stepped forward and took on the role. At the NEC in November the club formally marked the handover presenting Gary with a superb framed drawing of

him, on track, at the wheel of Gaps. Thanks again Gary.

So what does 2018 have in store for us all? Well we have started with a new look to Mascot that I hope you all like. Neil has some great ideas on how he can build on the success of Mascot and I am sure you will see some more subtle updates as we move through the year.

2018 is also significant for MASC as it will be not only 60 years since the launch of the Frogeye, the genesis for all our cars, but also 35 years since the club was formed back in 1983. As I am sure you all know we have a fabulous weekend planned over the 24-26th August at the Wroxall Abbey Hotel in Warwickshire. It promises to be a great event and planning is already well underway. The Sunday event will be a huge Sprite 60th Anniversary celebration party for all Sprites and Midgets held on the show field in the hotel grounds. We are extending the invitation to attend to members and enthusiasts from the other MG and Austin Healey clubs. Look out for more details in the next few months.

So enjoy 2018, go along to your local area meetings, start an area if you don't live close to one (the committee and other reps will be happy to help you), but most importantly enjoy your Spridget and have fun!

Mark
Chairman and Home Counties North West Area Rep

EVENTS CALENDAR 2018

- 7 Jan** London Bridges Run
- 10 Jan (8pm)** MASC Q&A evening with Fuzz Townshend, Stourbridge Rugby Club
- 11 Feb** Stoneleigh Park
- 22 April** Drive it Day to Bletchley Park
- 4-6 May** Donington Historic Festival
- 20 May** Dorset 60th Celebration
- 20-22 July** Silverstone Classic



Send your events details to editor@midgetandspriteclub.co.uk
Area Reps, Please remember that you can now add your monthly events on the Club's website.
Please contact Mike webmaster@midgetandspriteclub.co.uk

CLUB WEBSITE

WWW.MIDGETANDSPRITECLUB.CO.UK

Members Only Pages: Password: No longer applicable.
Please see page 6 of last month's Mascot for new log-in information



**WHY NOT FOLLOW
US ON FACEBOOK
AND TWITTER**

**MIDGET AND SPRITE CLUB (MASC)
@MASCUK**



1300 Facebook members as of 1st October

**WANTED
TECHNICAL
ARTICLES**



EVENTS DETAILS NEEDED FOR 2018

Area reps please make Neil Thomas aware of any events already in your diaries and any that are planned for 2018 so that they can be added to this section of the magazine and the website.

For the magazine Neil can be contacted at editor@midgetandspriteclub.co.uk
For the website Mike Bennett can be contacted at webmaster@midgetandspriteclub.co.uk

EXCLUSIVE CLUB SATURDAY OR SUNDAY DISCOUNT**

practical
CLASSICS

CLASSIC CAR & RESTORATION SHOW

With  Discovery

SPRING'S BEST CLASSIC CAR SHOW

23 -25 MARCH 2018 • NEC BIRMINGHAM

1,000 Classic cars on display | Over 150 Classic Car Club stands | 350 Specialist exhibitors & traders
Spring's largest indoor autojumble | Lancaster Insurance Pride of Ownership | Classic cars for sale & leading dealers
Classic Car Auctions | Practical Classics live stage | Carole Nash Barn Find
The Workshop, sponsored by SkillShack | Sporting Bears Dream Rides

SINGLE**
£16.50
QUOTE:
PCRS18CS

TICKETS ON SALE NOW!
NECRESTORATIONSHOW.COM

FAMILY**
£35.00
QUOTE:
PCRS18CF

In association with



Classic Cars



Sponsors



FREE ENTRY TO THIS EVENT FOR MASC MEMBERS

FBHVC DRIVE IT DAY 2018



Sunday 22nd April 2018

Following a successful event in 2017 MASC Members have been asked to return to Bletchley Park, the home of the WW2 Codebreakers and now a museum, to display their vehicles on FBHVC 'Drive it Day' 22nd April 2018.

The Mansion, Bletchley Park, Sherwood Drive, Bletchley, Milton Keynes, MK36EB
MASC Event Co-ordinator Richard Bowles richjbowles@gmail.com

LONDON BRIDGES RUN 2018

**Sunday 7th
January 2018**

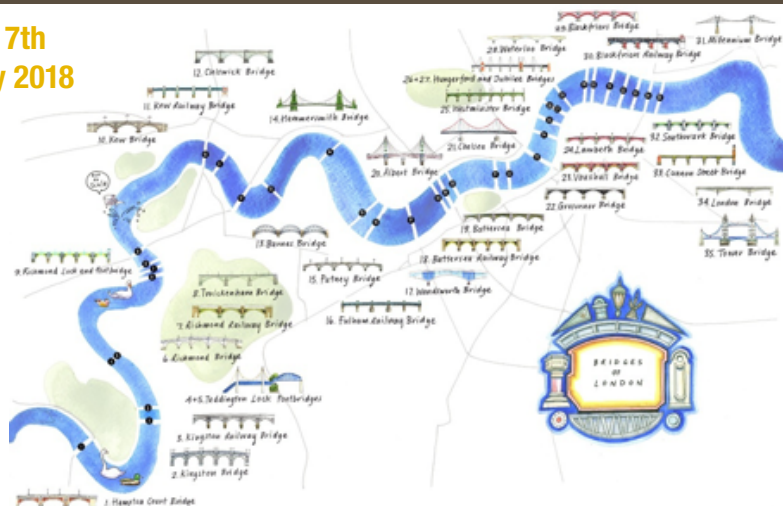

Come and join this popular season opener! Starting at 1000Hrs at McDonalds, Evelyn Street, London, SE8 5DQ. Participants drive the London road bridges, that span the River Thames, from Tower Bridge to Richmond where, if you choose, a lunchtime meal can be taken before heading home.

For more detail and the route contact: Darren Tyre at darren.tyre@ntlworld.com

NEW MEMBERS

NOVEMBER 2017 > DECEMBER 2017

We extend a warm welcome to the following new and rejoined members

5552	Richard Nunn	Oxfordshire	Midget	1500
5553	Pete Adamson	Derbyshire	Midget	Mk 3
5554	Nathan Hardwell & David Jefferies	Gloucestershire	Midget	1500
5555	Trevor Irwin	Antrim	Midget	Mk 4
5556	Peter Ohorn	Germany	Sprite	Mk 3
5557	John Carter	London		
5558	Alex Mckinlay	Surrey	Midget	Mk 3
5561	David Shepherd	Essex	Midget	1500
5562	Brian Scott	Kent	Midget	1500
5563	Dennis Tower	Tyne And Wear	Midget	1500
5564	Chris Roberts	Gloucestershire	Midget	1500
5565	Mark Koerner	USA	Sprite	Mk 1
5566	Tim & Sarah Robinson	Kent	Sprite	Mk 3



Here we have new member Brian Scott with one of his projects. Brian runs a business in Benenden, Kent, called www.retrocarspecialists.co.uk specialising in Midgets



Here we have recently joined member James Bacchus receiving the keys to his newly acquired Frog-eye Sprite

FRIENDS REUNITED



9 FYB (1981-82 to 1999)

In the early 1980's (81-82) my father Reg Bicknell "acquired" 9 FYB. He owned the chandlery in Wells Next The Sea, Norfolk and had carried out some work on a boat, when he delivered the boat back to the owner he couldn't pay, so my dad negotiated to take the Sprite in lieu of payment for the work done. This was so like my dad – he loved his classic cars. Dad really enjoyed the car and drove it around the North Norfolk roads, which are ideal for classic cars.

It was about this time that I moved to Norfolk and also had the pleasure of driving the Sprite.

In 1984, when Andrew and I got married, I had no hesitation in asking for the Sprite as our wedding car. It was great, fortunately it was a dry day in May but unfortunately there was a crop irrigator watering a field next to the road we had to go along to get to the reception and as we drove past it swung round and shot a great jet of water over the car – much to the amusement of our photographer in the car behind us. Never mind, I was only a slightly soggy when we got to the reception!

Dad used to take the car all around Norfolk and entered it into the Fakenham show, where a reporter took the lovely photo of dad and their Golden retriever – Sherpa in the front seat.

Sadly, in 1990, dad had a massive heart attack and died.

Knowing how much the Sprite had meant to dad, we decided to take it to his funeral. It received universal approval, some people smiled as they knew it was "so dad" others said they were doing well until they saw us in the car and that was just too much for them to hold back the tears.

Mum passed the Sprite to the 3 of us, myself and 2 brothers. It continued to live in Mum's home in Norfolk and we would use it whenever we were back at home.

In 1994 – Mum moved house and the Sprite needed to be rehomed within the family so she came to live with Andrew and me in Wales. We lived in Llangennith on the Gower Peninsular, another lovely area for driving a classic car.

In 1999, Andrew and I made a big move, selling our house and lots of our possessions to move to Tanzania. Neither of my brothers was able to take the Sprite so it was with great reluctance and sadness that we had to sell her.

She went to someone we knew, who lived in Bath and who used to restore cars, at the time he was going to do just that with the Sprite. (I secretly hoped that maybe we might be able to buy it back from him when we returned from Africa.)

Later in 2000, when we did return, I learned that he had sold it on and we lost the link to the car.

Over the intervening years I have kept an eye out for 9FYB and wondered what had become of her.

I was at the NEC Classic Car Show earlier in November and saw the Midget and Sprite Club stand and thought it would be worth asking if they had a register of cars. Sure enough, a couple of days after the show, Stuart Watson facilitated contact between the current owner and myself.

The car had been based in Cardiff, not that far from Swansea where we had lived.

A few days later I made the call to the last known owner and to my delight, he still had the car. He bought it in 2002 and has fully restored it and clearly enjoys and cherishes it.

She is now a lovely light green with dark green interior and looks in fabulous condition.



The owner told me that on their first long trip in the car, they were headed for Scotland.

Somewhere near the Lake District, around Penrith, the head gasket went and they had to spend a couple of days in the area whilst she was repaired. I found this fascinating because of all the places to break down enroute, it happened very close to where we live now and were living at the time, about 10 miles from Penrith!

My brothers and I are so pleased to know that 9FYB is still on the road and being lovingly cared for. She is a car for which we have a great deal of fondness and holds such dear memories of special parts of our lives. I do hope that one day I will be able to meet the current owner and actually see the car.

Thank you to Stuart Watson for helping me track her down.

LATEST FROM THE FBHVC



On the 18th December 2017, the FBHVC released the following press release:

Department for Transport (DfT) Guidance on Substantial Change of Historic Vehicles.

1. The Guidance sets out the definition of a Vehicle of Historic Interest (VHI), vehicles which will, from May 2018, be entitled to be exempt from taking a vehicle (MoT) test.
2. The Guidance reflects the outcome of intensive discussions between the DfT and the Federation of British Historic Vehicle Clubs (FBHVC). FBHVC wishes to express its appreciation of the open and collaborative manner in which the DfT approached these discussions.
3. In the discussions FBHVC was careful to take account of all possible members of the historic vehicle family.
4. The Guidance supersedes all previous potential criteria released for discussion by DfT.
5. The Guidance makes clear that it does not in any way affect DVLA's registration criteria and processes which remain unchanged.
6. The Government included motorcycles in the Motor Vehicles (Tests) (Amendment) Regulations 2017. As the Guidance implements the Regulations, DfT could not accept FBHVC's representations, based upon the requirements of the EU Directive, regarding historic motorcycles, so they are included in the Guidance.
7. Following STRONG representations by FBHVC, a vehicle may generally be a VHI if relevant changes were undertaken more than 30 years previously. This will be a rolling 30 years and replaces the fixed 1988 date previously proposed by DfT.
8. Major points of note are:
 - a. The process is one of self-declaration.
 - b. Owners will only be required to declare their vehicle to be a VHI if they wish to be exempted from an annual MOT Test.
 - c. All vehicles will still be able to be tested if their owners wish
 - d. The criteria are generic and permit changes made, less than 30 years prior to the declaration,

which improve efficiency, safety, preservation or environmental performance.

e. Those vehicles registered on a Q plate, as kits or built up classics are not entitled to be declared as VHIs until forty years after they were registered.

f. For motorcycles only the criteria of Q plates, kits and built up classics prevent declaration as a VHI.

9. The Guidance refers to "a marque or historic vehicle experts". A list will be published on the website of the Federation of British Historic Vehicle Clubs by 30th April 2018. Vehicle owners wishing to confirm if they may declare their vehicle as a VHI, may choose to contact the appropriate nominee from this list

10. FBHVC will be explaining the Guidance in full in its first Newsletter of 2018 and as soon as possible on its website at www.fbhvc.co.uk.

11. Text of the Guidance is at: https://www.gov.uk/government/uploads/system/uploads/attachment_data/file/668274/vehicles-of-historical-interest-substantial-change-guidance.pdf

Editors note: Our Chairman points out that if your car is manufactured before 1960, is currently exempt from an MOT, has been modified and falls outside the allowable mods, you will now need an MOT. People will need to be careful about this if they have a modified a Frog.





**VEHICLE TESTING
STATION**

Book your vehicle in for an MOT Test



VEHICLE HISTORY

Many of you will have used the DVLA form V888 to obtain a registration history of your car. For just £5 and a good reason to have this information, such as 'personal interest only', DVLA would provide everything that they may have on file.. However, from September 2017, form V888 has been revised so that the reason for obtaining information has been restricted. It is believed that DVLA have concerns over data protection issues when issuing information to applicants. This is a sad blow to

owners researching the history of their vehicles, unless of course, you can convince DVLA that you have a qualifying reason to obtain such information.

BREXIT

Other regulatory issues are often brought about by our membership of the E.U. For now, these still apply of course. It remains to be seen if new issues, now being tabled, will be adopted once we cease to be members. I think it fair to say that we in the UK are far more Historic Vehicle minded than many other E.U. member countries. Hence, proposed regulations from the E.U. do not always consider the Historic Vehicle movement or Motorsport vehicle owners. Currently, there are proposals concerning insurance, which if adopted, would impact many owners of such vehicles. Hopefully, the FBHVC, UK government and common sense will preclude further regulatory nightmares.

Specialist Car Insurance

Adrian Flux know how much you love your Midget or Sprite, that's why we are dedicated to finding you a policy, tailor-made to your own personal requirements and driving history. Call us today for a free, no obligation quote.



0800 916 1288
adrianflux.co.uk

Authorised and regulated by the Financial Conduct Authority

YOUR PRIDE AND JOY

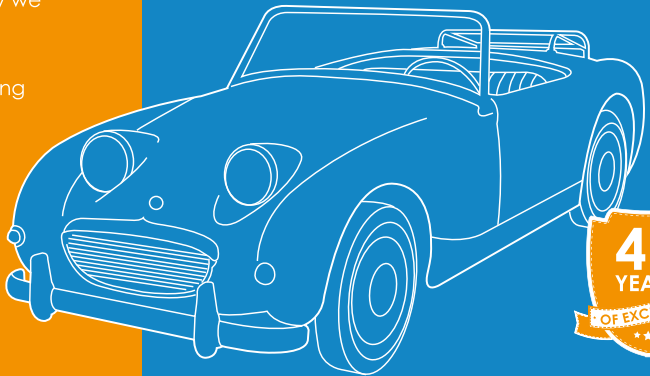

Benefits available can include:

- FREE Legal Cover
- Agreed Value
- Laid-up Cover
- Limited Mileage Discounts
- Breakdown Cover
- Club Member Discounts

A SHOCKING SITUATION

Does your car feel its age?



Rattles and Bumps
When shock absorbers are worn, the car will rattle and bump over bumps and potholes. This is due to the fact that the shock absorbers are no longer able to hold the car steady.

Hard Riding
When shock absorbers are worn, the car will ride hard. This is due to the fact that the shock absorbers are no longer able to hold the car steady.

Rolling on Corners
When shock absorbers are worn, the car will roll on corners. This is due to the fact that the shock absorbers are no longer able to hold the car steady.

Stopping with a Bounce
When shock absorbers are worn, the car will stop with a bounce. This is due to the fact that the shock absorbers are no longer able to hold the car steady.

Tiring Driving
When shock absorbers are worn, the car will be tiring to drive. This is due to the fact that the shock absorbers are no longer able to hold the car steady.

Over 75% of all new British made cars fit Armstrong Shock Absorbers

Models available for:

Alfa Romeo	1.6	1.8	2.0
Audi	1.8	2.0	2.8
BMW	1.8	2.0	2.8
Chrysler	1.6	1.8	2.0
Ford	1.6	1.8	2.0
Honda	1.6	1.8	2.0
Jeep	1.6	1.8	2.0
Land Rover	1.6	1.8	2.0
Lotus	1.6	1.8	2.0
MG	1.6	1.8	2.0
Mini	1.6	1.8	2.0
Nissan	1.6	1.8	2.0
Peugeot	1.6	1.8	2.0
Renault	1.6	1.8	2.0
Seat	1.6	1.8	2.0
Subaru	1.6	1.8	2.0
Suzuki	1.6	1.8	2.0
Talbot	1.6	1.8	2.0
Vauxhall	1.6	1.8	2.0
VW	1.6	1.8	2.0

Ask your garage to check.

FIT A NEW SET OF ARMSTRONG Shock Absorbers

REGULABLE - DOUBLE ACTING - SELF-REGULATING

LONDON: Price Equipment Ltd, 28, Arundel Road W. 22, (Opposite Grosvenor) Phone: 01-8388-6222

BIRMINGHAM: Shuter & Penhale Ltd, Fox Hollis Garage, 276, Fox Hollis Rd, Aston Lane, Edgbaston Phone: Aston Centre 0902

MANCHESTER: Douglas & Wilson Ltd, Wood's Bar, Manchester 12 Phone: 2569 0244

I got a new replacement set of shocks from Peter Caldwell, total cost was about £575 including the surcharge, postage and import VAT and duty. Not that bad considering. Clearly far better quality and no issues so far".

On my own cars I have also come across this problem. Where can decent new or exchange items be obtained? It appears not in the U.K.

I have now equipped my own cars with reconditioned front shock absorbers from Peter Caldwell. He can be found at:

World Wide Auto Parts of Madison, Inc.
2517 Seiferth Rd.
Madison, Wisconsin, USA. 53716

Peter Caldwell on his website explains what fails and how he effects restoration thus:

"First. What fails in a lever shock? Almost all of the (non-traumatic) failures result from lack of oil in the shock. The manuals always recommend checking or topping-up your shocks in various intervals 3000 miles or so. Why? Because they leak!.. what a surprise! They don't leak just because they are British, they leak by design (now there's a bumper sticker). Speaking here of the rear shocks... the shaft that protrudes from the body of the shock is rotating in the body without a bearing. To ensure sufficient lubrication there is often a channel or groove in the shaft bore. At the outside there is rubber packing retained by a thin metal washer. A packing needs some lubrication to work at all and the weeping of oil acts as a deterrent to dirt getting in.

Dirt getting in will score the shaft at the seal area hastening the demise of the packing and wearing the bearing surface in the body.

The solution that all of us rebuilders use is to machine the body and install a bearing. We use Delrin, others use bronze. Bronze requires oil, Delrin doesn't. We also machine the body for a rotary oil seal (others don't) (in fact we use a double lip seal with dust excluder). One guy does, now out of business did use a rotary single lip seal and the others use several rubber washers held in place with a steel washer or two. To solve the pitted and scored shaft problem, others sand or grind the shaft down.(you don't need to be precise with rubber washers) We have manufactured for us, to our specs, stainless steel sleeves that allows us to have a 3 micron finish and consistent diameter

At enquiries@midgetandspriteclub.co.uk and within my own area, Kent, I get many complaints about new and reconditioned parts for Sprites and Midgets.

About three years ago there were complaints about TRW brand dual master cylinders either leaking or suffering / causing residual pressure. I have had no complaints of late. Perhaps a bad batch?

By far and away the most complaints I receive are about either new or reconditioned shock absorbers.

The problems are arms pulling out, leakage of fluid; seized; tight in action or the reverse slackness of action: that is to say little or no resistance.

A recent and not untypical complaint:

"Sent all four shocks in for rebuilding. Three of the four I got back were faulty. Both rears leaked immediately and one of the fronts was dangerous after only a few miles - the lever popped out!! Not a great experience.

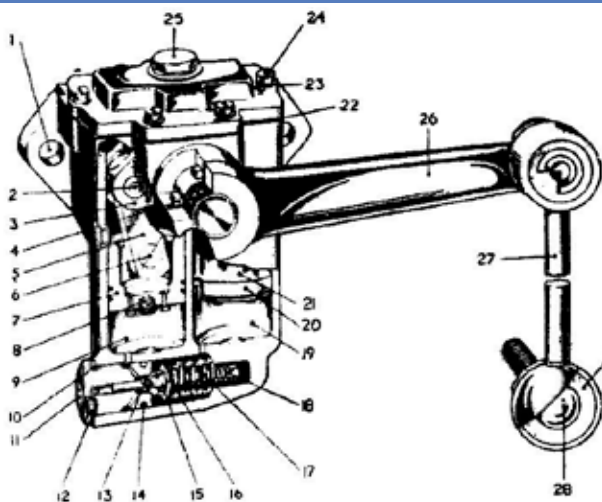

Fig. 11.15. REAR SHOCK ABSORBER COMPONENTS

- | | | | |
|------------------------------|--------------------------------|------------------------|--------------------|
| 1 Mounting holes | 9 Compression or bump cylinder | 16 Compression washer | 24 Lid screw |
| 2 Crank pin | 10 Ring seal | 17 Compression spring | 25 Filter gage |
| 3 Crank pin | 11 Valve screw | 18 Rebound spring | 26 Arm |
| 4 Oil seal | 12 Valve screw washer | 19 Rebound cylinder | 27 Connecting link |
| 5 Connecting rod | 13 Rebound valve | 20 Rebound piston seal | 28 Ball and bolt |
| 6 Piston pin | 14 Ring seal | 21 Rebound piston | 29 Rubber cushion |
| 7 Compression or bump piston | 15 Compression valve | 22 Gasket | |
| 8 Recuperating valve | | 23 Shockproof washer | |



and concentricity of the shaft. After many years, we have found this to be very reliable. Our shocks don't leak.

The process... step by step. Receive grimy old shock, tumble clean in a de-burring /tumble cleaner. Glass bead blast entire shock. Disassemble. Tumble and hot wash in ultrasonic tank internals. Bead blast the rest of the arm. Machine for the bearing and for the seal. Wash again. Press in bearing and seal. Press on sleeve. Inspect and repair / replace as necessary the pistons and the valving. Reassemble components using all new hardware of proper thread and style. Fill with oil and bleed. Compare valving with NOS (new old stock - AA) shock, adjust if necessary. Wash AGAIN. Paint 2 coats primer and 3 coats high heat black enamel. Date code and ship.

There you have it. I can provide details of the valving and design changes over the years, etc. But my carpal tunnel is acting up".

I did have two of Peter Caldwell's shock absorbers fail, soon after fitting, but they were replaced as Peter has confidence in his product and guarantees his work and to date all shocks are working well

and retaining their oil and, as is known, my cars (Frogeye and Sebring Rep') are used extensively at home and abroad.

There are, of course, alternatives to the standard shock absorbers. The Frontline front telescopic set up, that replaces the standard shock absorbers with a new arm and telescopic shock absorber, has been around, seemingly for years and is well spoken of. Frontline do a rear conversion as do Spax (which I have used for many years since building my Sebring Rep).

Mamba Motorsport do a front shock absorber conversion using a more period looking MGB lever arm shock absorber and no doubt there are others that I do not know about.

In the pipeline, and I hope to be able to report on this as soon as details are available, as a Kent member has been offered the chance to have the first fitting, is a front coil over shock set up.

Alan Anstead.
Kent Rep. Reps Rep to National Committee.
enquiries@midgetandspriteclub.co.uk
01322-384050 (answer-phone)

195 BHP ANYONE?



Hi, I am Steve Goodchild and the proud owner of a 1967 modified Sprite.

This journey started when I met up with Neil Thomas and John Austerfield on a track day at Trac Mon, Anglesey back in October 2016.

This meeting was by chance. I was there with my Gen 2 Porsche 911 called, "Precious". Neil was looking to buy one and took an interest in mine. He drove "Precious" around Anglesey and likewise I drove his K Midget. That was it, I was hooked! There was no escape as I felt myself naturally drawn to the Midget /Sprite scene, in part due to the friendliness and warmth Neil and his mates showed, but also the sheer fun that these modified K Series and Zetec engine Midgets and Sprites gave.

I had always liked Midgets and Sprites, especially modified ones, as this goes back to when I was at Technical college back in the early 1980's where one of our lecturers had a modified Sprite. It was his daily driver as well as motorsports car.

It took me until May 2017 year to find the right car, when I was lucky enough to be introduced to Kate Andrews who had decided to sell her much loved Tifosi Frogeye Sprite. I knew I wouldn't have time to restore and build my own car, so I was looking for one that was already built and with the right mods. Kate's was one such car that had had a lot of time and money already spent on it, so what a perfect car to start with.

Kate had developed the car over a period of some 5 years with her friend Rachel Finney, who sadly

passed away earlier this year. Still, her legacy lives on with this little car which I will be lovingly improving in years to come on what is a great base to start with.

It's a peppy little car is PYG (which is what I call it) with some 195bhp, proven recently on the Aldon Engineering Rolling Road shoot out, strongly supported by the small band of K Series and Zetec powered Midget and Sprites.

I've already taken it round Castle Combe Race Circuit, with that being the first time PYG had ever been around a track, and I'm pleased to report that nothing broke, leaked, or fell off. The day did reveal some areas I would like to improve but that was to be expected, the main one being the handling, as the rear wasn't that predictable at high speed. Good enough for road use but a bit tricky on track, but it will be sorted in good time. Everything else was great, especially that engine built by Dave Andrews at DVA Power.

I'm looking forward to this year and to some more motorsport events and trips out, to both MASC events and with the small band of merry men that own K Series / Zetec Midgets and Sprites.

It's been great being with these sets of people as they all have great communities, which is evident from the extent of knowledge, interests, events and especially the comradery. That's what matters, as it's not only the cars but the people side of these clubs that makes it really rewarding.

Long may it last
Have a great 2018.

Steve

KERMIT, A BRIEF HISTORY



I'm one of those people who tends not to keep cars very long. I buy something different and get bored with it quite quickly. However, one car breaks that trend, my MG Midget which I bought in 1982. It was a Mk2 Tartan Red 1098cc on wire wheels. Within a year, it had gained a 1275cc engine, steel wheels and turned lime green. Kermit was born.

I immediately started sprinting and hillclimbing it with some success. The car was developed and enjoyed into the early 1990's. But, at that time, I chose to lay it up with a view to building a Riley 1.5 to go rallying. That never happened as I started my own business which stopped any leisure activities! A few years later, I stripped Kermit down with a view to rebuilding him again. But, once again, due to various pressures, this didn't happen. The shell was grit blasted and primed so it didn't deteriorate any further. But it was in a sorry state with very few panels that weren't affected by the tin worm. By 2015, I was finally in a position to proceed with the rebuild and had taken a liking to the Sebring Sprite. A kit was ordered from Archers Garage, but sadly they were in trouble and closed their doors before my kit could be produced. I then ordered a bonnet and roof from CCK Historic and the Frogeye rear shroud from Smith & Deakin.

The steel shell required significant work. New panels included a complete floor, inner and outer sills, scuttle and bulkhead, A and B pillars, front chassis legs, front arch on one side, boot floor, rear inner arches and doors! The scuttle, pillars and doors are all Sprite Mk1 to match the Sebring body. A full 6 point roll cage with door bars was fitted at this point too.

After the metalwork was completed over a year or so, the GRP parts could be fitted up. These required some significant work to bring them up to standard. It has to be said the quality was rather disappointing. But, after much reworking and a fair amount of colourful language, the body was completed.

The Sebring body required me to manufacture a number of parts myself. The rear screen was Acrylic moulded over a former to fit the curvature. The side screens had to be made from scratch. This involved laser cutting Acrylic sections, forming aluminium channel around them and fitting a rubber seal across the bottom. Aluminium window knobs were turned on a CNC lathe.

Mechanically, the car was in pretty good shape as I had built most of it some 27 years earlier. What it demonstrated was the importance of using anti-seize compound on nuts and bolts. Everything, without exception, came undone without any hassle. The engine had only done around a thousand miles after it's last rebuild. However, 27 years of sitting around had left a little pitting in one of the bores. As it was bored to 74mm, I couldn't go any further, so another block might have been needed. My worries



THAT LEADS TO A SEBRING SPRITE...



were alleviated by a visit to Damico Engines where a rehone was enough to clean up the bores. They also fitted valve seat inserts to suit unleaded fuel. The last time it was used, unleaded petrol was hardly heard of in the UK! The valve guides were sleeved with Phosphor Bronze at the same time.

I was told my existing valves would be fine for use with unleaded fuel, so they all went back in. The oil pump was an original Concentric type with very few miles, so I chose to reuse it as modern ones can be poor quality.

New bearings were fitted to the existing crank which was still in good condition. The same applied to the camshaft.

My old company makes CNC machined aluminium parts for Mini's so a good few found their way onto Kermit's engine!

The exhaust is a Manifold item and I had the manifold ceramic coated to reduce engine bay temperatures.

Carburettor is a Weber 45DCOE on an old Manifold inlet manifold.

The gearbox was, again, still in great condition. Just a new shim for the first motion shaft bearing was needed.

The rear axle was rebuilt using Peter May half shafts. The differential was reshimmed, but is still noisy, so I'll need to sort out a new crown wheel and pinion at some point.

All the suspension that I had used previously went back on after cleaning and painting. New bushes were fitted throughout. I overhauled the front lever

arm dampers and revalved them in the process. I used 30wt oil from RedLine which is designed for vintage motorcycle forks.

The rear suspension was used as it was previously with the exception of a Frontline AVO damper kit in place of the previous Spax setup. I use a panhard rod and anti-tramp bars although the latter is less required these days as the tyres I'm using have far less grip!

I chose to go to 14" Minilite style wheels with 165/65 tyres. This keeps about the same rolling radius as the factory fitment but, in my view, looks nicer.

A new wiring loom was built based on one from AutoSparks. I have changed the layout of the dashboard to my liking and am using modern Smiths instruments with LED back lighting. The speedo is driven by an electronic pulse in place of the mechanical cable. So no more flappy needles or gloomy illumination!

The interior was carpeted with a part kit from Coverdale Carpets. A small amount of modification was needed, but they were generally very nice. Trim panels were also fitted to the interior to make it a nicer place to be.

So, after an MOT, Kermit was back out and about. I'm not going to be precious with the car. It's built to be used. So, it will remain ready to be used throughout the year.

Steve Nash

THE ALPINE MIGLIA TOUR 2017

In September I was fortunate to have the opportunity to go behind the scenes of an Alan Anstead European tour and experience it as a passenger in some of the participating members cars.

This started with a very early morning drive down the M1 to London to join my first host Kevin, and his very tidy old English white Mk3 Midget. Passing through the leafy Surrey lanes then along the Kent motorways as the sun came up we headed for Dover. The 5-speed Ford gearbox resulted in a particularly smooth ride without the associated gearbox noises one would get in a standard car. I was more surprised to learn that the suspension set-up had standard shock absorbers all round, achieving an extremely stable and rattle-free ride. The result of a well maintained car with good quality parts.

As we approached the port of Dover we caught up with Ron and Victor in Ron's "standard" but immaculate blue frogeye, shortly before joining Alan in his Sebring Sprite, Dave in an Isle of Wight frogeye, and Robin in a Tifosi Rana.



Disembarkation at Calais

Mistletoe-lined roads



Thiepval Monument

France:

After a reasonable ferry crossing and disembarkation, the five cars regrouped in Dunkirk in order to put the tops down, while Alan outlined the route plans. Now with a 360 degree panoramic view and clear weather ahead, the empty country roads of France looked more inviting. Avoiding motorways as much as possible, we headed south-east across former WW1 and WW2 battlefields, passing military cemeteries and monuments which brought home the extent of fighting across France. We saw the towering Thiepval Memorial in the distance and decided to visit to pay our respects.

Designed by Sir Edwin Lutyens, the 45 metre high memorial tower commemorates more than 72,000 men of British and South African forces who died in the Somme before 20 March 1918 and have no known grave, the majority of whom died during the Somme offensive of 1916. It is the largest

Commonwealth memorial to the missing in the world.

The following morning we visited the historic town centre of Laon and its cathedral. The town hosts the “Circuit Historique de Laon”, an annual classic car event popular with many Brits.

I switched to the Tifosi Rana, previously owned and well sorted by Dave Chalk and now owned by Robin. The 1500 engine displayed much more torque than the 1275 and together with its 5-speed gearbox gave a very calm low-revving ride with more potential in reserve. Robin had cleverly set up his brakes to produce an audible squeal each time our convoy came to a halt so we knew when he had caught everyone up.

Vast expanses of flat arable fields stretching to the horizon gave way to the undulating landscape of the Champagne region, where pickers gathered in the grapes from rows of vines, waving as we



Reims road circuit buildings

passed, on our way to Reims and Epernay. We made a planned stop en route at the remains of the Reims Circuit, whose weather-beaten pits and grandstands stand eerily either side the public road still in daily use.

Disused after the final races in 1972, the buildings have largely escaped demolition and are maintained by a group of enthusiasts, providing great photo opportunities for these time-warp monuments as

a backdrop to our classic cars. Plans to revive the buildings with a museum are uncertain.

Our journey continued through France the next day accompanying Dave Chalk in his Isle of Wight Supersprite. I really was being spoiled now, as again the car had a 5-speed gearbox mated to its 1275 engine, so keeping down revs and noise. The seats were extremely comfortable, although to account to his height Dave had done some major surgery to the driver's side in order to achieve his ideal



Reims pits



...and the search reveals....
an allen key!

Mulhouse Museum facade



lower driving position – with a view through the windscreen as opposed to over the top!

My chance to drive one of the cherished cars came that morning, when I was invited to demonstrate to Robin the technique for removing stones stuck behind the brake disc. This involved finding a quiet stretch of road – not too difficult – along which I could perform a series of manoeuvres such as driving rapidly in reverse and a slalom down the centre of the road to try to shake the offending article out. Once the ‘ping’ was heard as the stone flew out, silent braking returned once more. Unfortunately the noise caused by Robins lack of anti-squeal shims persisted....

We pushed on along Alan’s route, avoiding motorways where possible, to the National Museum of automobiles at Mulhouse, where the stunning Schlumpf collection of “over 400 exceptional cars” is housed in a former textile warehouse formerly owned by the Schlumpf family. The collection truly is unique. It’s fascinating story can be Googled for anyone wishing to know more than I have room to tell here, or if you are ever passing that way, I recommend a visit.

I was invited to experience the section of the route into Switzerland in Alan’s Sebring Sprite. Yet another 5-speed, but this time with a fixed roof which masked the joyous sounds of exhausts in tunnels and cold outside. Now in the mountains with snow capped peaks, Alan and I were oblivious of the drop in temperatures outside had we not seen the others wearing woolly hats and gloves.

By now we had been joined by a number of European based Spridgets from France, Switzerland and Germany, whose owners demonstrated how to drive on the opposite side of the road.

To be continued....





For some it's the age...



For some it's the iconic status...



For others it's the marque...

Whatever your definition of classic we know you love it.

Here at 2Gether we feel the same and have done so for over a decade.

Tailor made specialist insurance solutions from the specialists.

Some of the benefits our policies can provide:

- Club Member Discounts
- Agreed Value
- Limited Mileage Discounts
- Free Legal & Accident Management Cover
- Breakdown Cover

2getherinsurance.co.uk

01945 586220





Central members enjoying their Christmas meal.

Party Time

The last Central monthly meeting of the year will be remembered for party hats and crackers as for the first time we decided to make the meeting coincide with our Christmas meal. A table for 10 was reserved, which became 12 then 15 then 18 and the final tally came to over twenty. This number of people caused some concern for the Pub staff as they knew seating that amount of people was going to be a tight squeeze in the room where we usually meet. However, this was not going to be a problem for Central members, as the clashing of chairs and being able to talk to the person so close behind only added to the jovial, noisy atmosphere.

We were lucky to have been served on the evening by the Deputy Manager Phil and waitress Jenni who had welcomed us with open arms since our move there. Their service was excellent along with piping hot food that everyone seemed to agree was delicious.

I felt it only fitting to ask Jenni to draw the first raffle prize and Gary Hendon was quick to claim the bottle of Prosecco with Pam McKenzie claiming the second, a large Panettone cake. Also, in the raffle was a wrapped mystery prize claimed by Keith Jewkes, who rather nervously opened it fearing the worst but was surprised to find it was a book about the greatest road trips of the world. He was soon ticking the ones to add to his list of must do's. The proceeds from the raffle were donated to the Air Ambulance charity. My thanks go to everyone for joining in and making our first Christmas at the Tame Otter such a special one.

So 2018 here we come. Events are already starting to be arranged with some already booked. This is the year of the Classic Le Mans, already in our diaries. We also have the Sprite MASC event at the end of August to look forward to. As monthly events start to be confirmed I will do my best to compile a list of local events Central members may

be interested in. Perhaps there is an event you are thinking of attending that I don't know about. Why not let me know so I can give other Central members the chance to come along too.

Let's make 2018 the year we all get out and about in our cars together.

Dave Warren
Central MASC
 Email to central.masc@live.com

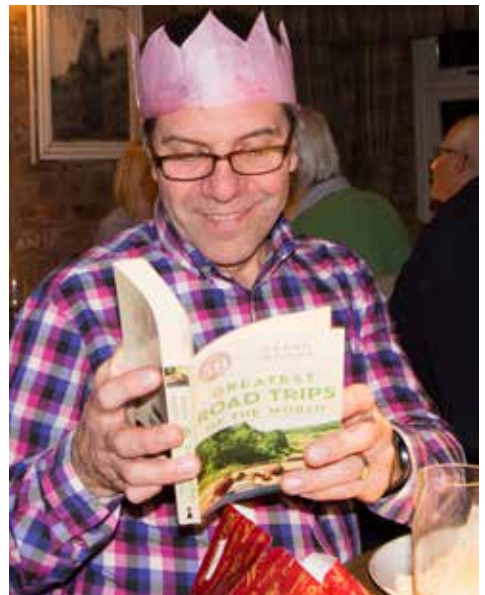

Keith Jewkes opening his mystery raffle prize.

JOHNS JOTTINGS DORSET

Below you will see an advertisement for the Dorset Area Frogeye Sprite 60th 'birthday party' event which we are arranging.

Our plans are falling into place well and entry forms will be available in early January. We hope to include a line-up of all HAN and GAN cars from Frogeye to Rubber Bumper models and are keen to locate a 9-stud Frogeye to start off our timeline. Anyone owning one would be very welcome indeed as we have no early Frogs in the club locally.

The talent of people sometimes surprises me and with only the thinnest of briefs local Midget owner Dave Hindson came up with the adjacent artwork which we plan to use in publicising the event.

The framed original artwork will be raffled on the day of the event, Sunday 20 May; all proceeds going to our chosen charity, The Dorset Cancer Care Foundation.

Our proposed visit to Guernsey next May with our cars attracted lots of interest and we now have a party of 15 cars and 29 people scheduled to enjoy a four-day break on that wonderful Island. Sadly bookings have now had to close.

Local member on the island, Matt Birch, has been inspired, if that is the right word; to try and complete the restoration of his car by the time we arrive next May. As he is at the 'let's wend that' stage we can only wish him luck and whether the car is finished or not it will be good to meet up with an overseas member!

Our AGM has been scheduled next year for Sunday 11 February and we will then draw up our plans for the

year to include the events already referred to above together with our staple events such as the BBQ, evening road run and festive meal. We would welcome ideas for activities from other local Spridget owners who perhaps find it difficult to support our regular Monday evening club nights.

The Dorset Area has had a good year, but what we really want is more participation from members. Perhaps we are getting it wrong and if people tell us what they want for themselves and their cars we could encourage more participants for our ventures.

On now to our Festive meal ... in January.

Clear roads ... John Gully, Dorset Area Representative.

DORSET AREA MIDGET AND SPRITE CLUB
AUSTIN-HEALEY SPRITE 60th BIRTHDAY PARTY
SUNDAY 20 MAY 2018
AT THE HOLME BUSH INN, CORFE MULLEN BH21 3RZ
FREE ENTRY BY PRE-BOOKING - CLASSICS ONLY

HAPPY 60th

Holme Bush Inn will provide Live Music, a pay BBQ and will also be open for meals
 *Tombola: *Win a Bottle of Wine stall: *Cake stall: *Trade Stands

All proceeds to "Dorset Cancer Care Foundation" with a collection as cars depart

Entry forms will be available from early January

To register your interest and join us please email Ian Beaver at: ian.beaver@btinternet.com



Cambridge Rebores Ltd Engine Reconditioners

Quality You Expect On Time

see our website for more information



www.cambridge-rebores.co.uk

Some of our services include: Unleaded Conversions, Hot Pressure Testing, Refacing, Flywheel Grinding, Line Boring & Honing, Con Rod Reconditioning, Crankshaft Regrinding & Dynamic Balancing, Reboring & Sleaving.

Phone: 01638 743797 Fax: 01638 743781 Email: sales@cambridge-rebores.co.uk
Unit 1 Broads Road Business Park, Burwell, Cambridgeshire CB25 0BT



QUALITY SPRITES & MIDGETS ALWAYS WANTED Especially Frogeye and Pre-74 cars

We specialise in selling quality Vintage & Classic Motor Cars and the above have always been a particular passion. We are located between Petersfield and Alton in Hampshire, between the A3 & A32 in the beautiful South Downs National Park.

*Vintage &
Classic car
specialists
with over
45 years
experience*

Robin Lawton

Tel: 01420 474919 Mob: 07710 364945
Email: enquiries@robinlawton.com Web: www.robinlawton.com

*Cars
Purchased
for Cash
or Sold
on Clients
Behalf*



The main event this month was the Mascmas meal, however global warming struck us and carpeted East Anglia in possibly the thickest layer of snow I have seen (in these parts) for many years. Sadly, common sense had to prevail and we (and a few others) missed out (hopefully this event will be reported on next month), however we did have another fun social event as reported below by Diane.

Ten of us attended the bowling event at Pidley. On arrival we picked our lanes randomly to spice things up. Unfortunately I was unable to bowl, as I was recovering from keyhole surgery, so Nigel happily volunteered to step in and to play left handed as I'm left handed, he didn't let on that he had been practicing left handed a few months ago when his elbow was out of action!! So I was disappointed when he was only getting 3 pins down on my turns, he tried to blame the molehills in the lanes! (a common problem in the fens). Jo set the standard by getting a strike on her 1st go (well done!!) For the girls Jo came 1st and for the boys, you guessed it, Nigel, the winner for the most strikes was a joint 1st for the boys of Mick and Nigel with 3 strikes each and for the girls was also joint 1 strike each for Mary and Jo.

I suspect there was some cheating going on in the other lane in the final game as eager Graham got an impressive 9 pins down, his best of the evening, but on his return to his seat he saw his name up to bowl next so he excitedly went to bowl again only for everyone to shout "no" you have just had Mick's go! So Mick went up to bowl not realising that if he had gutterballed one throw Maggie would have beaten Graham (which would have delighted "almost" everyone) instead Graham won 4 points more than Maggie (the payment of the bribe must not have been enough!!).

After bowling we had a meal which had mixed reviews some had good food some had warm food and cold instead of warm chocolate brownies so we will rethink food next time.

Now someone, Chris I think, came up with a new idea for the winter months of a darts evening (hoping Nigel cannot play this!) Everyone is excited about this idea so watch this space and see if we can find a venue.

The darts thing sounds like a brilliant off-season idea to me or maybe extend it to include other traditional pub games.

Unfortunately the snow didn't hang around for long enough for me to "slip" out for a short trip in the Sprite to take some seasonal photos so I have included a library photo instead.

See you all at the oldest Inn in England and far beyond.

Dave Dixon (AKA Red and sometimes blue Leader) e-dave@hotmail.co.uk





We held our traditional two events in December. On the 3rd, Tim & Linda again organised the Santa Run. With a couple of the planned finish venues not being available due to conflicting Christmas activities, some late changes to the intended route were necessary.

Under the watchful eye of shoppers at Morrisons in Witham, 3 Sprites and 3 Midgets [plus 1 modern] assembled for the fancy dress judging. With the judging over, the convoy headed towards

Silver End which is a model village conceived by the industrialist Francis Crittall who established a factory in the village. Then followed a series of narrow windy lanes leading to Coggeshall.

After passing the NT owned Paycocks House, a short section of the A130 preceded a series of lovely minor roads towards Stisted and then to the finish at The Barn Cafe in Greenstead Green. After enjoying tea and cakes served by Santa's little helpers, both the Best Dressed Car and the Best Dressed Crew awards were duly presented with Francis & Gill for the second year running.

On the Friday after the regular monthly meeting, we held our Christmas Dinner at a new venue. Following a very successful visit to The Crown in Messing on one of our evening runs, Gary & Diane agreed to book it for the end of year event.

With 26 [ie 100% of our membership] attending, it was obviously a popular choice. The format of the evening, with a quiz and award presentations sprinkled between courses, followed a proven path.

Paul, the quiz master, must have trawled through some early '60s magazines for the questions such as:



Trophy winners L to R Owen & Lucy, Colin & Elaine, Dave, Tony

- 1 Where was the nearest Austin Healey dealer?
- 2 What tyres were fitted as standard equipment?
- 3 What was the most popular petrol used by Sprite owners?

Answers at the end.

The Area equivalent of Ant and Dec, aka Gary & Tim, performed the host duties with lots of flair and exuberance.

Several previous winners were amongst the nominations for the prestigious Breakdown Trophy, featuring a AA car on a wooden plinth, but the eventual winners were Owen & Lucy for losing the exhaust from their Sprite whilst on the London Bridges Run.

Dave Matthews was presented with the Member of the Year for his attendance, determination and repair skills.

Two additional awards for 2017 were presented. The Timekeeper of the Year Trophy, featuring an Alarm Clock, was after a lot of head scratching presented to Colin & Elaine. The Run of the Year Trophy winner was Tony for organising the July run from Marks Tey to Assington.

With a score of 9 out of 16, Francis showed his in depth knowledge of all things Spridget to win the quiz set by Paul.

The evening wouldnt be the same without some welcome lyrical input from Paul. The full words will be in next months report.

What better way to end another year of Spridget ownership than a lovely meal with enjoyable company. Looking forward to the next season.

Quiz answers:

- 1 Marks Tey, 2 Dunlop, 3 Esso

Doug Plumb

Award

It is now safe to reveal that the winner of the inaugural Jim and Rosemary Willis Trophy, which recognises the outstanding Heart of Englander of 2017, is Stuart Watson!

The main reason for members voting for Stuart was his selfless decision to put his head above the parapet and take on the mantle of organising a second MASC National Event. This one will take the form of the Sprite 60 celebrations in 2018 at Wroxall Abbey, which I'm sure you know by now. The reason that this picking up of the baton in the absence of any other offers is so worthy of praise is because Stuart is already MASC membership secretary which is a very demanding committee post, as renewal requests require constant attention and of course we signed up 47 new members at the recent NEC Show, all of which of course have to be processed by Stuart. A worthy winner indeed!

Julian and Alex Willis present the Willis Trophy.



Surprise guests at our Christmas Dinner on December 13th specially invited to present the Trophy, were Jim and Rosemary's two sons Julian and Alex. Julian made a fine speech and announced Stuart as the winner and Alex presented the pre-engraved Trophy. They stayed for a beer or two and got roped into participating in Janet Hunter's (this year aided and abetted by my wife Ange) legendary Christmas Quiz. They waded in with good heart but were confused by some of the adjudicator JH's rulings eg "which car manufacturers' emblem is a Viking Longship?" 100% of quizzers answered "Rover" with full confidence. "Incorrect" retorted the Quizmaster, "Lada" is the answer. "Well Rovers



is as well!" we protested. "Well I didn't mean that one and the Quiz Master is always right!" was the self assured reply We realised that it was futile to mount any further protest and marked all of our Rover answers as incorrect! There was also a good picture round where celebs in their formative years had to be identified. See pic for the example of the one that we found the toughest! (Answer at the foot of this report.)

Fuzzy Guest at January Meeting.

Star of TV's Car SOS, Fuzz Townshend recently opened a new Classic Restoration business in the West Midlands and held an Open Night to publicise it. I was lucky enough to attend and asked Fuzz if he would be prepared to do a Q&A evening for MASC. Being a fine chap, he said that indeed he would and the best way to do it would be in his capacity as Ambassador for Carole Nash Insurance





and that way there would be no cost to the Club. John Platt and I visited the Carole Nash stand at the NEC in November where Fuzz was holding court, and confirmed a date of January 10th.

By the time you are reading this it is either just about to happen or has happened in the last day or two depending on how speedy our printers are feeling after Christmas. As I write, the plan is to open the event up to all MASC area members who fancy attending and we may also open it up to other Midlands based Classic Car Clubs in order to make it a bigger event. Indeed the event falls on the date

when we normally have the H of E monthly meeting, but we have changed the venue to Stourton Park (Stourbridge Rugby Club DY7 6QZ) so that we have room to expand if needed. We will run a raffle during the evening in aid of Primrose Hospice who were a great help and comfort to Jim and Rosemary so a local good cause will benefit.

**Happy New Year
Steve**

Mystery youthful celeb? None other than Janet Hunter!



**The world's leading
Austin Healey
parts supplier!**



www.ahead4healeys.co.uk
Tel. 0044 (0)1788 565 000
Fax. 0044 (0)1788 565 001
info@ahead4healeys.co.uk

A Head Healeys

81 Somers Rd, Rugby, Warwickshire, CV22 7DG, UK



**WANTED URGENTLY
MIDGETS AND SPRITES**
Excellent prices paid for Frogeyes, Original or
IOW
In any condition



Up to £8,000 paid for Midgets
and £17,000 for Sprites
Tel Mike on 07703 465224
Or mike@mgmidgets.com

Kent is traditionally divided into West Kent and East Kent by the River Medway. This division into east and west is reflected in the term "Men of Kent" for residents east of the Medway; those from west are known as "Kentish Men". The female equivalents are "Maid of Kent" and "Kentish Maid". However some towns, such as the Medway Towns - Rochester, Chatham and Gillingham (although Rainham was annexed from Swale, and is thus considered part of East Kent) and Maidstone, lie on the east / south bank of the river.

Meeting of the Men and Maids of Kent at Sarre on Sunday 12th November 2017.



The midweek promise of dawn to dusk sunshine did not look likely early on Remembrance Sunday when rain and wind was revealed when opening the curtains. Tea and read the paper looked far more inviting. We had planned a morning Run to set up our appetites for lunch at Sarre so dedication to duty had us on the road to the start point at Faversham at 9.30. The rain had turned to drizzle and sunny periods although sidescreens, passenger rug and heater on at full blast (wishful thinking) were definitely the order of the day. Six cars assembled on time for the off and with forms signed, maps issued we were off. Well sort of, the little convoy immediately split up having us then sitting in a layby saying "where are they?" or words to that effect. That matter sorted, we arrived at our planned tea stop from two directions. The café, not your usual roadside establishment, was at a garden/wildlife centre at Chilham. Would it be a big fat goose or a

long legged rhea for the table? They had them all. Well they all escaped as we weren't agile enough. After refreshments we took the cross country route via Chartham, Bridge, Wingham and Preston arriving exactly on time at The Crown. Some of our number were unable to stop but were replaced by others whom had travelled direct for lunch.



The usual good fare was available and eaten with gusto with matters of great importance discussed over lunch.

The Christmas Dinner, booked for December 15th, is only a month away. Limited places are still available as are rooms for the night. Little interest so far for Tours next year so little incentive to actually do more detailed planning at this time. That said, a UK tour in a SW direction has had some work put into it by Phil Manship. More details later.

Richard J sent his apologies for not attending the lunch. He has had electrics installed in an attempt to be 6 million dollar man but feels at this time that they have left the toolbox inside. Get fit soon Richard.

Finally Carole Clark expressed her concern that the Isle of Wight tour was not on again this year. She has a rather pressing appointment on the Paradise isle to sort out her offshore finances.

John Clark Co-ordinator for the Men of Kent.

Classic Car Show at NEC on Sunday 12th November 2017.

I shall try to keep this brief as the Show will get much exposure elsewhere in the Club Magazine. A big thanks to Alan Pritchett who organises the stand

for the Club. If you would like to have your Midget, Sprite, or derivative displayed or you would like to try being 'front of house,' representing the Club, at future NEC shows, then do contact Alan as cars for display and committed volunteers are always wanted.

Alan.

Tuning and diagnostic day. Saturday 18th November 2017

Today was another tuning and diagnostic day with A.C.Dodd at M.L.Motorsport, Higham, Kent.

A brace of Kent MASC cars were to be presented to 'A.C.' to perform his magic upon.

First up was Richard Bowles Sprite: today wearing its hardtop to shield Richard from the rain.

Apart from a CSI distributor the engine is standard. A.C. had recently reconditioned the carburettors. Conversion to more freer flowing air filters was recommended. Alarmingly the S.U. Carburettors were suffering a dichotomy with regard to the fuelling needles taper requiring a dramatic transition. This ailment was treated by A.C. with careful polishing and whilst Richard was pleased with today's result A.C. has asked him to bring the car back for more improvement due to constraints on time.



Next was John Wheatley's Midget. A.C. had again reconditioned the carburettors and also

re-curved the distributor. All that was left was to modify the S.U. needles for precise fuelling and set the ignition. A.C. reckons that with more time he can still make improvement.

Last car under the spotlight was Bryan Williams Midget. This car has a modified head, Piper 285 camshaft, distributor without vacuum advance and a single HIF carburettor.

Carburettor and timing adjustments were carried out with a recommendation of a larger air filter as the one fitted was not flowing enough cubic feet per minute of air to supply the carburettor. Wondering why Richard & John had moved closer to the car it could be seen that the exhaust manifold was glowing red and giving off much welcome heat on this overcast day. Apparently the glow was related to the lack of vacuum advance but a necessary trade off, with this engine specification, without losing some performance.

An Audience with A.C.Dodd

If we can assemble ten persons we will have another 'Audience with A.C.Dodd' next year when

members, from any Area group, will be able to ask technical questions on tuning A.Series engines and S.U. Carburettors.

Alan.

Drive it Day 2018

Bletchley Park, once the top-secret home of the World War Two Codebreakers, is now a vibrant heritage attraction. Bletchley Park is at Sherwood Drive, Bletchley, Milton Keynes, MK36EB (use MK36DS for Sat Nav). Following a successful visit this year (2017) MASC has been invited to return to a car show on Sunday 22nd April 2018. 22nd April 2018 is also FBHVC 'Drive it Day'. This appears to be a good opportunity for several, if not many, MASC Area groups to get together so to this end I have contacted all Area reps. Entry is free!

**Contact event co-ordinator: Richard Bowles :
richjbowles@gmail.com**

(Reps please let Richard know how many of your members are attending)

Alan.

'Old Boys' run to a private Motor Cycle Museum. 22nd November 2017

(If you live outside the County of Kent, as some of our participants do, but would like to join us on 'Old Boys' mid-week Runs then get in touch and I can add your details to our e-mailing list. Our major Tours at home and abroad are usually advertised in MASCOT for all to join).

Eleven Sprites, Midgets, and derivatives assembled at the Service area Jct8 on the M20.

Two from Sussex and one from Surrey. Keith Warner, from HCNW, had been given a disclaimer to come in a modern due to distance and the current chaos (farce) that is Dartford Crossing & M25 Motorway. The organiser of this run Dave Chalk used a modern as his IOW Froggy seats are currently with Mel Collins' son for refurbishment having seen the quality of Mel's new leather coverings. With a large convoy the size, and white colour of Dave's car, was a visual benefit to all as we wound around the lanes calling first at the excellent Cock Inn, Boughton Monchelsea, to hand in our lunch requests and reduce our number of cars as parking at our destination was limited. Brian Keywood rode with Dave but was able to report that his Midget rebuild progresses towards

probably held as many parts and accessories as a main dealer whilst the mezzanine floor held more parts, motorcycles to be restored and motorcycles for which there was no where else to place. We were led past lathe and milling machine to the museum. A narrow path had to be negotiated among row and row of superb BSA and Norton machines with the odd 'other' make here and there. Cars such as Jaguar XK150, Aston Martin, Rolls Royce fought for space toward the rear of the display. Upstairs there were more with Vincent, Matchless, & Velocette were on a raised centre display that concealed the vehicular lift.

Our tour ended with a display in a lock up garage holding the eighteen machines that are for regular use.

The dwelling where Mr Talbot lives was, allegedly, once owned by Richard Lewis Hearne, OBE (30 January 1908 – 23 August 1979). Richard Hearne was an actor, acrobat, dancer, comedian, producer and writer best known as the bowler-hatted creation Mr. Pastry.

Richard Hearne was resident clown at the BBC for thirty years. He was born in Norwich in 1908 into a theatrical family. His father was an acrobat and his mother a dramatic actress.

The slapstick antics of Mr. Pastry brought Hearne rich financial rewards. In one week on American television he appeared before an estimated 120 million viewers and received a £2,500 fee: a lot of money in days of old. On a previous trip, his earnings were calculated at £125 a minute.

Our tour complete, we returned once more to the Cock Inn for lunch. Once lunch was eaten and digested, a photo shoot took place as the Landlady asked for a picture of the cars using the Inn as a backdrop. And thence our various ways home!



paint. Upon our arrival we were met by the owner of the motorcycle collection that we had come to see, Mr John Talbot, who then guided us through his workshop where we met his full time mechanic who builds, modifies, restores and also enjoys the many various machines in the collection. The store



Alan.



Wroxall Abbey / Sprite 60th Celebrations. 28th August 2018.

Stuart Watson and his team are working hard on organising this event and as far as the Abbey Hotel is concerned it really was the case of 'the early bird getting the worm' as apart from a couple of single rooms the Hotel and Gala dinner were quickly sold out. Fear not there are other Hotels where one can stay and no doubt that information will be available elsewhere.

We are attempting to attract 'Historic cars' to the 26th August 2018 Sunday 60th Celebration of the Sprite on the events field next to the Abbey. So far we have attracted a Sebring Sprite from the 1959 team and a period racing car. If members know owners of Historic Cars can they pass on details and contact numbers please so that invitations may be sent. Also will members with multiple club allegiances spread the word as all Sprite, Midgets, & derivatives are welcome to this Sunday gathering.

Also is there interest for a car badge similar to those produced for the 50 years event (insert pic thumbnail 3) but not coloured. Price estimate is £20-25 per item.

Alan.

London Bridges Run on Sunday 7th January 2018

This popular season opener is to be held once more. It attracts Spridgeteers from afar.

Starting from McDonalds, Evelyn Street, Deptford at 1000Hrs participants drive their cars first across Tower Bridge and thereafter, sequentially, every

Thames road Bridge to Richmond, Surrey. At the finish many lunch together in a pub.

Contact Kent member Darren Tyre for more information or to enter: darren.tyre@ntlworld.com

Kentish Men & Maids meet at the Angel, Addington Green, on Sunday 26th November 2017.

This will be the last meeting of the year at the Angel as we, historically, do not have a meeting in December other than the Christmas Meal that this year will be held in East Kent.

Even with temperatures at about one degree several come top down on this sunny day.

Conversations varied from table to table with continental tours discussed on one whilst fitting a Ford Zetec engine to a Sprite / Midget was discussed on another. As soon as details are forthcoming re Tours at Home and Abroad I will broadcast in MASCOT to include all.

Kent's Ghosts.

It is a widely held belief that Pluckley in Kent is the most haunted village in Kent. Ghosts have been experienced on the roads and in the village buildings. Kent MASC has its own Ghosts people who exist on a spreadsheet but whom we have never seen. Come on Folks do make an effort next year. It would be nice to see you at least at one Kent MASC meeting or event so "Lets be seeing yer".

Alan Anstead

Kent Rep. Reprs Rep to National Committee.
enquiries@midgetandspriteclub.co.uk
 01322-384050 (answer-phone)



As we write this report, some of you might be frozen in and for a change it is not us in Lancashire & the Cheshire area! Luckily, despite the weather conditions, those members that had booked for our Christmas Lunch at the Swan with Two Nicks at Bollington on Sunday 10th December, all managed to get there (and back) safely!

Despite some snow starting to fall during our meal, which was slightly worrying, fortunately it was not enough to trouble us on the way home. It was a cracking day with some excellent food and service. Graham & Val were the only ones to brave the conditions and arrive in their MG Midget, well done!!! We will all be looking forward to seeing them both next year in their new addition to the family, a lovely green Frogeye.

We have quite a lot of activity within the club already with some members at the moment, Bernie & Mike, already having taken their engines out for repair & maintenance. It's a labour of love or might be and it just keeps us out of harms way in the garage instead of under the feet of "her indoors" "!! Anyway it all has to be done as 2018 looks like being a busy year with several big events already booked. Again we in the North West will be clocking up the miles, with some trips planned to France & in the south of England. Because of the amount of spares that we now have to carry "just in case", on these longer trips we are getting significantly larger and taking up more room. The

only problem we now have is persuading our wives/ partners to take a smaller suitcase. Guess who will win?



By the time this report is in print, we will be in to the first meeting of the New Year 2018 and will be wondering how we are going to finish all the jobs we have started. Will we be back on the road for March when we will be hoping for some good weather to come our way and we can get back on the road for that shakedown run?

Neil & Shelley North West Area Reps.





At the end of November one of our local members suggested a run out into Derbyshire as the forecast, although cold, was to be bright. The mid-week rendezvous near Ripley saw just four of us making the most of the weather at such short notice. Alan and Richard in Midget 1500's, Ian in his 1275 Midget, all tops down, and myself in a somewhat warmer MX5 with hardtop! Ian "two hats" (it was very cold!) proposed what would be a 60 mile route taking in a tea stop at Tissington, followed by chips at Ashbourne.

It was then decided to wash the food down at The Holly Bush pub in Makeney and final farewells at our current monthly meeting place, The Hunters Arms in Kilburn. The roller coaster route around the countryside at this time of year displayed Derbyshire's wonderful autumnal scenery in splendid sunshine. Richard still believes he doesn't need a heater!

We hope this may become a regular event for the 2018 calendar, and propose to call it "The Young Boys Run" on the basis that some of our members have reached a certain age with more time on their hands. Of course any of our female members are welcome to join in and turn it into a "...boys and girls run".

In December one of the local Spridget suppliers "A-Series" held a festive open day, which brought



out many local Morris Minors and Minis despite the snow flurries. Warm drinks and mince pies were certainly welcomed. Local MASC members in attendance discussed ongoing restoration projects and modifications. We hope to see Antony's Midget on the road soon.

Please keep in touch with any suggestions and ideas for events.

Hope to see even more of you in the coming year.

Ian Cooke
Notts + Derby Area rep.
ilcooke@btinternet.com





Oh well, we are back to the cold, frosty and wintry conditions that arrive at this time of year and our cars are tucked up in their garages and lock-ups. Most people will be like me, pump the tyres up a bit, wax the chrome bits and put it under the cover, and turn the engine over a couple of times in the next few months. However, one of our members, David, has his two cars nicely stored away in their carcoons, with air constantly being pumped round them keeping the damp at bay. I like this idea and looked at them at the N.E.C. in November. I decided that, in my garage, I would end up catching them with something or other causing a rip or tear and that would be the end of that.

One of our newer members to the Scottish area who will not have that problem is Bob. He shouldn't have that problem because he lives in Texas! Bob is restoring a Midget modified for racing and once he has completed his restoration hopes to compete in some historic racing.

Another new member to the Scottish area is John, from the Isle of Man, who is currently restoring a Midget in which to go hill-climbing. He also has a Frogeye which is a long term project; although he has a Wheeler & Davies bodyshell, so I think he may finish quicker than myself and the Rusty One.

I hope that the two of them keep me informed of their restorations and their sporting endeavours thereafter.

The Mascot has just popped through the letterbox and it was interesting to read the letter from

Richard Weaver and his collection of badges, I don't think I have seen so many Austin Sprite badges together, so all you badgeless Austin Sprite owners start badgering Ahead 4 Healeys.

To accommodate the new pieces of kit I have purchased, I decided to have a tidy up in the garage. It, ended up like rearranging the deck chairs on the Titanic; but when I got the news that the M.G. garage had started the repair on the good Frog and it should return to the stables in a fortnight I became Action Man with a can of Cillit Bang, It's amazing what a deadline can do!



We had to cancel this month's beer & bletcher night due to inclement weather which was a pity, as the previous month's meeting we had our best attendance in years. Hopefully we can continue increasing our regular little posse of attendees.

Graham



November started with a day out at the annual Footman James restoration show at Shepton Mallet. For once it remained reasonably warm all day which encouraged many more visitors vying for the bargains on offer. To be fair little in the way of good 'Autojumble' was being displayed but the many traders were offering all types of fastenings, fabrics, tools and services between them, including some hard to find rarer old hand tools, some of which were from original equipment car-tool-kits from a bygone era.

A mid month meander around SE Somerset found us on the outskirts of Shepton Mallet again at Pylle for a bite to eat at the Jon Thorner's Farm Shop. The return home was punctuated with a final stop at Perry's Cider Mill, near Ilminster for tea and cake.

The following week another run out this time around SW Somerset was organised by Malcolm and Elaine Denman. The route took us from Broadwindsor to Beaminster and using several narrow and hilly roads through pretty villages we stopped at the Sutton Bingham Reservoir. We attempted to continue through Ryme Intrinseca to Yetminster but unfortunately the road was closed for maintenance so we headed straight for the finish and lunch stop at the Penn Mill Hotel, in Yeovil. Just as well as soon afterwards the heavens opened with the rain falling well into the evening.

21 members attended the popular monthly meet/eat evening in November at the Stonemasons in Ilminster, and although somewhat colder than previous meets with the lively chatter and hot food we were soon nice and cosy.



We ventured across the border into Devon for the Annual pre-Christmas lunch at the Lakeview Manor, near Dunkeswell. Many parts of the country had experienced a heavy snow fall during the night; however we were fortunate in the west at only having rain, and lots of it. But at least it was not freezing and everyone made the venue safely dodging the few puddles along the way.

So ended another year with Somerset members having shown a presence at 20 shows, completed 10 end of month and 7 midweek runs, and 11 monthly meet/eat evenings. Many of the group are associated with other clubs in the region and also officiate for motor clubs at sprints, classic trials hill climbs and rallies, keeping busy most weekends during the year. When did us retirees ever have time to actually go to work!

Peter Young



DEAR MASCOT...

Dear Neil,

"Here are some photos of my 1977 MG Midget US 1500. I have had this car, "MeG", for almost 12 years and have loved every minute... When purchased, the body and paint were basically as you see in the pictures. I have done a lot of work on the interior, engine bay, and added details throughout. I purchased the hardtop about a year ago. It took almost 6 months to find and install the correct rubber seals. But I feel it was well worth it. When at car shows or gatherings, the car stands out due to its small size and the fact that there aren't many Midgets on the road today. I have run into many people who had a Midget in their younger years and reflect on their former ownership. We do get a good amount of snow here in Pennsylvania USA, but due to the large amount of salt put on the roads, the

Midget does not get to feel the snow beneath her tires.

I do run across some other Midgets from time to time. I try to take part in the annual show put on by the Philadelphia MG Car Club every October, which gives me the opportunity to meet up with several other Midget owners."

**Ken Samen 4270,
Pennsylvania, USA**



STOLEN

We haven't seen much of Andrew Dawson, Kent's youngest member, during his membership of MASC, as University and then a new career took much of his time. He then moved away from the family home in Sevenoaks to Brixton, in London. The car remained garaged, in a lock-up, in a block near the family home in Sevenoaks.

I was able to assist when he took on the challenge of rebuilding the car's engine and then with fitting that engine. Andrew and his girlfriend used the car when they could, travelling on one occasion to St Tropez in company with a friend of theirs that owned an MG Midget.

It is now some weeks since Andrew discovered that his Sprite had been stolen from the lock up garage.

It's a Mark IV Austin Healey Sprite 1969, registration TLD 698G in Brooklands Green, chassis no: HAN9-78290, Engine no: 12V588FH2208. It's fitted with a roll bar, manifold exhaust and a big air filter with Sprite written on the casing.

It also still had a number of Le Mans stickers on and their names behind the doors.



To date there is no news of recovery so that it appears the car is lost forever. Having spoken with Andrew it is unlikely that the car will be replaced with another Sprite nor Midget and the club will probably lose Andrew as a member.

Alan Anstead

WHERE ARE THEY NOW?



HI NEIL

YES, I'M A MASC MEMBER (NUMBER 5136 - THERE'S A 'THE PRISONER' REPLY IN THERE SOMEWHERE)

I was wondering whether my first cars were now languishing in a barn somewhere waiting to be discovered as neither appear to be on the road.

My very first car - A 1098 Sprite with wire wheels, FVW 260B - no showing on the gov mot site.

It was originally BRG if I recollect correctly but I brush painted it OEW with coach enamel. It didn't too bad and certainly a lot better than 'Ratty' my current Spridget.



My second car was a Teal blue 1275 Midget with early Rostyles-, PLG 182H. It shows on the mot history gov. site as now red and hasn't had a mot since records began.

I owned these cars back in the late seventies/early eighties when I lived in Cheshire. Would love to see more recent pics of them.

**BEST REGARDS
ALASTAIR WILSON**



**HI NEIL
NOT SURE IF YOU CAN INCLUDE THE ATTACHED
IN A FUTURE MASCOT.**

**REGARDS
JOHN CLARK**

Bill Reeves

I was sad to hear of the passing of Bill Reeves in November following a period of illness. Bill may well have been known to Midget owners in East Kent as he operated an MG repair and parts business at Birchington and latterly at Manston. I have spent many a Saturday morning sitting in the sunshine outside the workshop drinking tea with him then trying to find a new or secondhand part for my Frogeye. He often stated though that Midget owners were the worst. They would want a cheap secondhand part rather than pay £1.25 for a new one. I don't think we were talking quality here, just penny pinching. I spent more than a few pennies here to say the least!

Anyway I attended the funeral, well I assume there was one as Bills instructions were to just meet at the pub at Sarre for a buffet and arrangements would be made elsewhere to send him on his way, just throw the ashes to the wind. Sounds just like Bill. It didn't quite go to plan though as roads closed by accidents on two of the three routes to the pub meant an extended drive around to actually get there. Was he looking down or as his Wife said looking up from below and having the last laugh.

Just to close though Bill's pension fund included a rubber bumper Midget which he spent quiet moments at work rebuilding. It was a one owner car long unused which bore a Queens Jubilee logo on the rear panel. It was a mystery to him and whilst he was in the parts business he was unable to discover anything about it. The poor quality photo attached is all I have although the car is still around. Any information anybody?

JOHN CLARK, EAST KENT

THE WHO, THE WHAT & THE WHERE OF THE MIDGET & SPRITE CLUB

COMMITTEE

CHAIRMAN	Mark Hall, T: 01296 660103 E: chairman@midgetandspriteclub.co.uk
GENERAL SECRETARY	Glyn Polly, T: 07544 302 575 E: glyn.polly@gmail.com
TREASURER	David King, T: 01453 544202 E: djs.king46@gmail.com
EDITOR	Neil Thomas, T: 07891 684435 E: editor@midgetandspriteclub.co.uk
AREA REP'S DELEGATE MEMBERSHIP	Alan Anstead, T: 01322 384050 (Answerphone) E: alan.anstead@btopenworld.com Stuart Watson, "Staddlestones", Thicknall Lane, Clent, Stourbridge, West Midlands. DY9 0HX. T: 01562 883076 E: membership@midgetandspriteclub.co.uk
GENERAL MEMBER	Alan Pritchett, T: 07720 238810 E: a.pritchett@btinternet.com Gary Lazarus, E: garyfrogeye@gmail.com T: 020 7700 5696 Richard Wharmby, T: 07814 764546 E: r.wharmby10@virginmedia.com
FACEBOOK COORDINATOR	

OFFICERS

CLUB ARCHIVIST & TECHNICAL DOCUMENTATION	Terry Horler, 63 Littledean, Yate, Bristol, BS37 8UQ. T: 01454 881770 E: rebelwithasprite@hotmail.com
MEMBERS ADVERTISING	Alan Lo, E: alan@mobuzzing.net T: 0117 9572617 Mob: 07474 343643
CAR REGISTERS	
SPRITES & MIDGETS (EXCEPT MK1 SPRITES)	Stuart Watson, E: stuart@thewatsonz.com T: 01562 883 076
SPRITES MK1	Gary Lazarus, garyfrogeye@gmail.com T: 020 7700 5696
REGALIA OFFICER	Mike Grout, 55 Park Road, Spixworth, Norwich, NR10 3PJ. T: 01603 890211 E: miketg54@hotmail.com
TECHNICAL ADVISOR	Mark Boldry, E: mark26r@hotmail.com
WEBMASTER	Mike Bennett, webmaster@midgetandspriteclub.co.uk T: 01925 727479
TRADE ADVERTISING	Gary Lazarus, garyfrogeye@gmail.com T: 020 7700 5696

AREA REPRESENTATIVES

BRISTOL	Terry Horler, T: 01454 881770 E: rebelwithasprite@hotmail.com
CENTRAL	Dave Warren, T: 07831 101850 E: central.masc@live.com
DEVON	Michael Ellis, T: 07527 598091 E: michael_ellis@live.co.uk
DORSET	John Gully, T: 07876 334949 email john.gully@btinternet.com
EAST ANGLIA	David Dixon, T: 01733 222810 E: e-dave@hotmail.co.uk
ESSEX	Gary Knight, T: 01376 562172 Mob: 07932 077305 E: gknights@live.co.uk
HAMPSHIRE	Terry Langridge, T: 01252 626063 E: friendlyfolk@midgetandsprite-hampshire.info
HEART OF ENGLAND	Steve Newton, E: newton-gemini@sky.com
HOME COUNTIES	Mark Hall, T: 01296 660103 E: markdhall@aol.com
NORTH WEST	
KENT	Alan Anstead, T: 01322 384050 E: alan.anstead@btopenworld.com
LINCOLNSHIRE	Currently vacant
LONDON	Gary Lazarus, T: 020 7700 5696 E: garyfrogeye@gmail.com
NORTH WEST	Neil McLeod, T: 01772 466648 Mob: 07921 089 680 E: neil_mcleod2@outlook.com
NOTTS/DERBY	Ian Cooke, T: 0115 938 3838 E: ilcooke@btinternet.com
NORTH NOTTS & SOUTH YORKS	John Austerfield, T: 07778 636070 E: austerfield.07@btinternet.com
OXFORD	Grahame Gibbins, T: 01235 530456 E: grahame_gibbins@hotmail.com
SCOTLAND	Graham Smith, T: 0141 954 8276 E: smith.grahamf@yahoo.co.uk
SOMERSET	Valerie Young, T: 01460 391431 E: peteryoung81@aol.com
SOUTH WEST WALES	David Hill, T: 01239 811307 E: david@hill.be
SURREY	Mike Gorman, T: 01737-552256 E: gorman698@btinternet.com
SUSSEX	Chris Harding, T: 01342 718860 E: harding.cm@btinternet.com
WILTSHIRE	Andy Cross, T: 01225 743554 E: andyspeedbox@gmail.com
YORKSHIRE	Rob Armstrong, T: 07889 090411 E: mascyorkshire@gmail.com



ALSO SEE THE CLUB NIGHTS SECTION FOR NEW AREAS AND CONTACTS

Compiled by Neil Thomas. Please advise me of any changes, errors etc.

MEMBERSHIP REVIEWAL:

If you experience 'MASCOT' problems upon renewal, please contact the membership secretary or the treasurer straight away.

CLUB NIGHTS

- 1st Saturday **YORKSHIRE AREA.** Meet each month at lunchtime from 12:30pm at The Nags Head, Pickhill, near Thirsk, YO7 4JG – more information at <http://yorkshiremasc.blogspot.com/>
- 1st Tuesday **ESSEX AREA.** Now meet at The Green Man, Green Man Lane, Kelvedon Road, Little Braxted, Essex CM8 3LB. For further details contact Gary Knight, Tel: 01376 562172 Mob: 07932 077305 email: gknights@live.co.uk
- 1st Wednesday **CENTRAL AREA.** Now meet each month 8.30pm onwards at the Tame Otter, Lichfield Road, Hopwas, Tamworth, B78 3AF, 8.30 pm onwards Contact: Dave Warren, Tel: 07831 101850. Email: central.masc@live.com
- 1st Wednesday **OXFORD AREA.** Meet at the Blackhorse Pub, Gozards Ford, Nr Abingdon. 7pm for those eating or 8pm for those not. Contact Grahame Gibbins at grahame_gibbins@hotmail.com
- 2nd Tuesday **LONDON AREA (CONGESTION ZONE).** Meet at The Ace Cafe at 7:30pm together with the Classic Cars Magazine night. Details: Gary Lazarus on 020 7700 5696 garyfrogeye@gmail
- 2nd Wednesday **DEVON AREA.** Meet at Court Farm, Abbotskerswell, TQ125 NY Devon. Michael Ellis Michael_Ellis@live.co.uk and telephone: 07527 598091
- 2nd Wednesday **HEART OF ENGLAND.** All welcome at the Green Dragon, Sambourne, Redditch B96 6NU for 8.30 start. To check "what's on" please email Steve Newton on newton-gemini@sky.com
- 2nd Wednesday **NORTH WEST AREA.** Meet at The Kilton, turn off M6 at Jct 20 onto A50 towards Macclesfield. Pub 4 miles on left. Please note new venue. Neil McLeod email neil_mcleod2@outlook.com Tel 01772 323770 Mobile 07921 089 68
- 2nd Wednesday **BRISTOL AREA** will meet at Wishing Well, Wapley Road, Codrington, Bristol BS37 6RY. From 8.00pm – or earlier for a Curry enjoyed in peace! Contact Terry Horler 01454 881770 rebelwithasprite@hotmail.com
- 2nd Thursday **NOTTS/DERBY BORDER AREA.** Meet at the Sitwell Arms at 30 Wood Lane, Horsley Woodhouse, Derby, DE7 6BN from 7.30. Just a mile north-west of the A608/A609 crossroads. Ian Cooke 0115 938 3838 ilcooke@btinternet.com
- 2nd Thursday **EAST ANGLIAN AREA.** Previously the Cambridgeshire Area meet at The Ferry Boat, at Holywell, 8pm
- 2nd Sunday **NEW EAST KENT GROUP.** Meet at the Crown Inn, Sarre, CT7 0LF from 1230hrs Contact alan.anstead@btopenworld.com
- 3rd Tuesday **SCOTLAND.** Meet at Houstoun House Hotel, Broxburn, EH52 6JS. Meetings start at 7.30pm. Graham Smith 0141 954 8276 email: smith.grahamf@yahoo.com
- 3rd Tuesday **SURREY.** Meet at The Chequers, Chequers Lane, Walton-on-the-Hill, Surrey KT20 7SF. 7.00pm onwards. Contact Mike Gorman, gorman698@btinternet.com Tel: 01737 552256
- 3rd Sunday **NEW NORTH NOTTS & SOUTH YORKS GROUP** meeting is from 10am. The Courtyard Tea Room, Womersley, north of Doncaster DN6 9BH. Contact: John Austerfield austerfield.07@btinternet.com 07778 636070
- 4th Monday **DORSET.** New Venue: Holme Bush Inn, Old Wareham Road, Wimborne, BH21 3RZ, 01202 659420 Contact John Gully. Tel: 07876 334 949 email: john.gully@btinternet.com
- 4th Thursday **SUSSEX.** Meet at Bolney Stage, Bolney, RH17 5RL from 19:00.
- 4th Thursday **HAMPSHIRE.** Meets at The Golden Pot, Old Odiham Road, Shalden, Alton, Hampshire, GU34 4DJ. Please ring Terry or Harriet Langridge on 01252 626063 for details.
- 4th Sunday **KENT AREA.** Back at The Angel, Addington Green, Kent until further notice. Contact Alan Anstead enquiries@midgetandspriteclub.com
- Last Monday **WILTSHIRE.** Meet at The Barge Inn, Seend, Nr. Devizes, about 7pm. Contact Andy Cross on 01225 743554 or email andyndspeedbox@gmail.com
- Last Wednesday **HOME COUNTIES NORTH WEST** for members in Herts, Beds, Bucks, Berks, N. London or anyone interested! Meet at the Chequers Inn, Redbourn, AL3 7AD from 6:30pm. Please contact Mike or Sue Gahan on email mike@mgahan.demon.co.uk or on 07850 488636.
- Last Thursday. **SOMERSET AREA.** Meet at Stonemasons Pub & Restaurant, Ilminster TA19 9DJ. 7pm if eating, 8 to 8.30pm if not. Please contact Valerie Young on 01460 391431 for further information. We may not always be there, especially in the Summer!
- Northern Ireland robertholmes25@hotmail.com. If enough interest, will arrange a meeting.
- South West Wales Non-regular and occasional meetings and runs arranged throughout the summer months. Please contact David Hill on 01239 811307 or email: david@hill.be

MARKET PLACE



FOR SALE - 1275 Midget - £4,500. Call Ted Milbourn on 01483 222138 (Woking, Surrey) for further details.

FOR SALE - Speedwell Monza bonnet for sale. Needs some work but quite a rare bonnet. £250
Neil 07891 684435

FOR SALE - 1275 engine for sale. Thin flange with single carb manifold and gearbox. Turns freely. Will need strip down. £450.
Neil 07891 684435

FOR SALE - Midget wheels for sale:
5 x wire wheels £30 (insert photo wire wheel 1)
5 x wire wheels, blasted and primed £60
4 x early Rostyles, £20
6 x later Rostyles, £30
Neil 07891 684435

FOR SALE - Mk1 Midget Hardtop. Needs refurbishing. £50
Neil 07891 684435



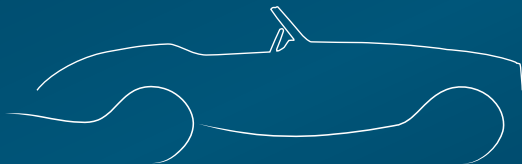

QUALITY AUSTIN-HEALEY SPRITE PARTS!

Our team are ready to assist with our fast and friendly service. We have vast stocks so order fill rates are unrivalled by any other Healey parts supplier.

Whatever your Austin Healey requires, buy it from the company who understands your needs and shares your passion.

For **Austin-Healey Sprite** models: Mk 1 Frogeye, Mk 2, Mk 3 and Mk 4, Midget



Visit our website www.ahspares.co.uk

Tel: 0044 (0)1926 817181 | Email: sales@ahspares.co.uk

Westfield Road, Kineton Road Ind. Est. Southam, Warks. CV47 0JH, UK

Frogeye Spares

“Knowledge, Expertise & Passion”



The Manufacturer of Wheeler & Davies Frogeye Bodyshells

Virtually EVERYTHING in stock
to build a complete Frogeye!

Specialising in new & used parts, complete
new body shells, servicing & restoration
of Austin-Healey 'Frogeye' Sprites.

For all your Austin-Healey Sprite needs, look no
further for friendly service and competitive prices!

Call the experts today on
+44 (0)1204 604 017

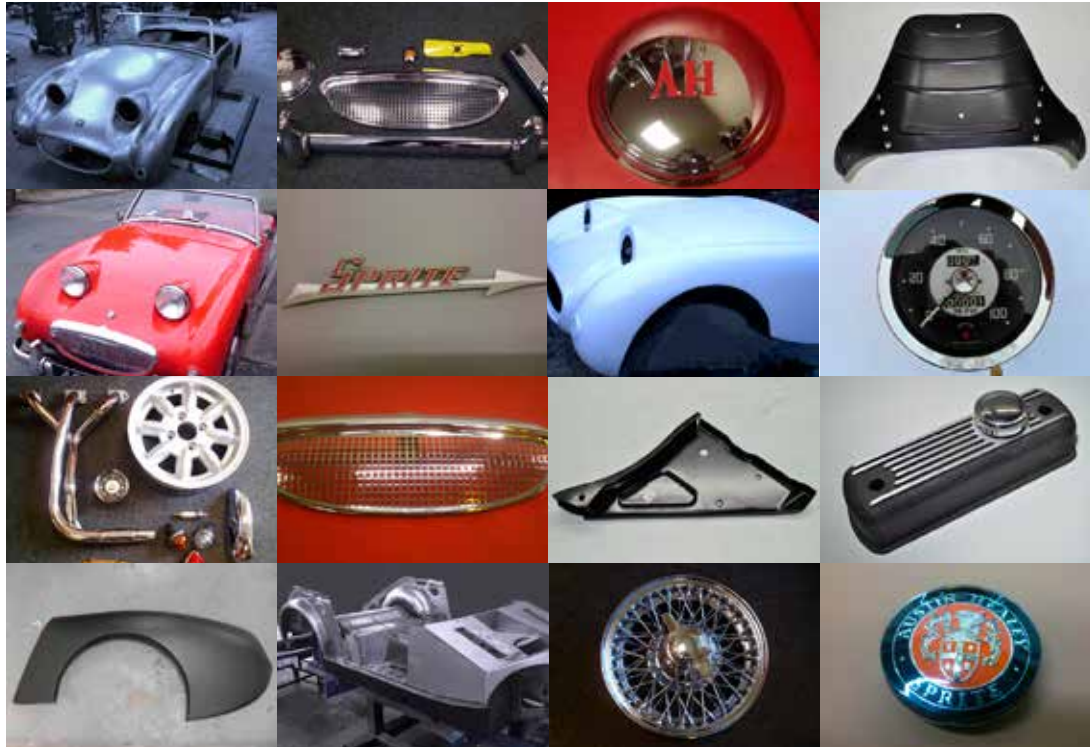

Visit www.frogeyespares.co.uk or email enquiries@frogeyespares.co.uk