

# Mascot

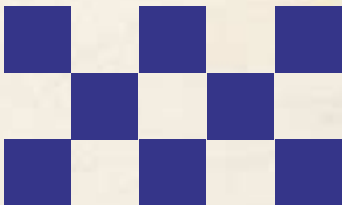

The Magazine  
of the  
Midget & Sprite  
Club



# Move your insurance up a gear with Aon



Most insurers will treat you as just another customer – Aon treats you as an individual.

As a traditional insurance broker offering a first class standard of care, we will provide a car insurance policy that perfectly complements your unique driving needs.

Whether you're covering a classic, sports or everyday car our Client Managers will deliver a professional insurance solution that's tailored to your specific requirements.

As a member of a car club we can offer you up to a 10% discount off your premium.

To discuss your requirements further, please call us on

**08705 70 80 90**

[insureyourcar@aon.co.uk](mailto:insureyourcar@aon.co.uk)

[www.specialistcars.aon.co.uk](http://www.specialistcars.aon.co.uk)

**AON**

Aon Limited is authorised and regulated by the Financial Services Authority in respect of insurance mediation activities only. Telephone calls may be recorded or monitored. FP3608.02.07

**Classic, Sports & Prestige Cars • High Value Home • Investment Property • Holiday Home**

# THE WHO, THE WHAT & THE WHERE of THE MIDGET & SPRITE CLUB

## COMMITTEE

<b>CHAIRPERSON</b>	<b>Nigel Williams</b> , 7 Kings Avenue, Hanham, Bristol BS15 3JN. Tel: 0117 961 2175 email: nigelwilliams7@tiscali.co.uk
<b>GENERAL SECRETARY</b>	<b>Vacant</b>
<b>TREASURER</b>	<b>Anita Lachowicz</b> , 5 Park Grove, Knaresborough, Yorks. HG5 9ET. Tel: 01423 862738 Mobile: 07720 725429 email: spridget.girl@ntlworld.com
<b>WEBMASTER</b>	<b>Toby Anscombe</b> , 7 Lysander Court, High Road, North Weald, Epping, CM16 1HF. email: tobyanscombe@taratec.co.uk
<b>TRADE ADVERTISING</b>	<b>Gary Lazarus</b> , 40B Hungerford Road, London, N7 9LP. Tel: 0207700 5696 email: garylazarus@blueyonder.co.uk
<b>GENERAL MEMBER</b>	<b>Bill Mohan</b> , Tel: 0121 353 7211 or mobile 0798 461 6371 email: bill.mohan@btinternet.com
<b>GENERAL MEMBER</b>	<b>Philip Sellen</b> , 40 Amberley Way, Wickwar, Wotton-under-Edge, Glos, GL12 8LP. Tel: 01454 299222 email: P.N.Sellen@bristol.ac.uk

## OFFICERS

<b>MAGAZINE EDITOR</b>	<b>Barry Lowe</b> , email: editor@midgetandspriteclub.co.uk Tel: 01943 608900 10am to 9pm, UK time
<b>MEMBERSHIP</b>	<b>John Platt</b> , 2 Pear Tree Gardens, Bearley Road, Aston Cantlow, Henley-in-Arden, Warks. B95 6HT Tel: 01789 488321 email: membership@midgetandspriteclub.co.uk
<b>CLUB ARCHIVIST</b>	<b>Terry Horler</b> , 63 Littledean, Yate, Bristol, BS37 8UQ. Tel: 01454 881770
<b>TECHNICAL ADVISER</b>	<b>Vacant</b>
<b>EVENTS CO-ORDINATOR</b>	<b>Vacant</b>
<b>MEMBERS ADVERTISING</b>	<b>Alan Lo</b> , Tel: 0117 9572617 Mob: 0775 3867806 email: alan@mobuzzing.net
<b>MUTUAL ASSISTANCE</b>	<b>David Hill</b> , Llyserfan, Beulah, Newcastle Emlyn, Ceredigion. SA38 9QB. Tel: 01239 811307 email: david@hillnet.clara.net
<b>CO-ORDINATOR</b>	<b>Bob Clarkson</b> , Tel: 01902 842643 email: raclarkson@tiscali.co.uk
<b>CAR REGISTER</b>	<b>Mike Grout</b> , 55 Park Road, Spixworth, Norwich, NR10 3PJ. Tel: 01603 890211 email: mike@motorparts.freemove.co.uk
<b>REGALIA OFFICER</b>	

## AREA REPRESENTATIVES

<b>BRISTOL</b>	<b>Terry Horler</b> , Tel: 01454 881770
<b>CAMBRIDGESHIRE</b>	<b>David Dixon</b> , Tel: 01733 222810 email: e-dave@ntlworld.com
<b>DEVON</b>	<b>Vacant</b>
<b>DORSET</b>	<b>Ian Beaver</b> , Tel: 01722 326840 email: ian.beaver@btinternet.com
	<b>Bryan Fox</b> , Tel: 01202 683842 home, 01202 674017 work email: sueandbry@x877.wanadoo.co.uk
	<b>Vacant</b>
<b>ESSEX</b>	<b>Terry Langridge</b> , Tel: 01252 626063 email: Hampshire.spridget@ntlworld.com
<b>HAMPSHIRE</b>	<b>Chris Jackson</b> , Tel: 01707 261567 chrispat@holwell8.freemove.co.uk
<b>HOME COUNTIES</b>	or <b>Mark Hall</b> , Tel: 01296 660103 markdhal@aol.com
<b>NORTH WEST</b>	<b>Alan Anstead</b> , Tel: 01322 384050 email: alan.anstead@btopenworld.com
<b>KENT</b>	<b>Brian Jeffery</b> , Tel: 01522 531425 or mobile: 07952 969514 email: brianlincs1ot@yahoo.co.uk
<b>LINCOLNSHIRE</b>	<b>Gary Lazarus</b> , Tel: 020 7700 5696 email: garylazarus@blueyonder.co.uk
<b>LONDON</b>	<b>Bill Mohan</b> , Tel: 0121 353 7211 or mobile: 0798 461 6371 email: bill.mohan@btinternet.com
<b>SOUTH STAFFS &amp; NORTH BIRMINGHAM</b>	
<b>CENTRAL SCOTLAND</b>	<b>Carson Thomson</b> , Tel: 0141 245 6327 day or 013606 22334 evening email: THOMSON.C@sky.com
<b>NORTH WEST</b>	<b>Les &amp; Diane Robinson</b> , Tel: 01772 432138 email: lesrobinson@blueyonder.co.uk
<b>NORTHERN IRELAND</b>	<b>Vacant</b>
<b>NOTTS/DERBY</b>	<b>Ian Cooke</b> , Tel: 0115 938 3838 email: ilc@bgs.ac.uk
<b>SOMERSET</b>	<b>Dave Bearne</b> , Tel: 01823 412004 email: david.bearne@lloydtsb.co.uk
<b>SURREY</b>	<b>Alan Anstead</b> , Tel: 01322 384050 email: alan.anstead@btopenworld.com
<b>WARWICKSHIRE</b>	<b>Alan Couch</b> , Tel: 01564 773302
	<b>Chris Yates</b> , Tel: 01608 665066 email: chrishe@tiscali.co.uk
<b>WILTSHIRE</b>	<b>Vacant</b>
<b>YORKSHIRE</b>	<b>Anita Lachowicz</b> , Tel: 01423 862738 or mobile: 07720 725429 email: spridget.girl@ntlworld.com

Also see the Club Nights section on page 4 for new areas and contacts.

Compiled by David Hill. Please advise me of any changes, errors etc.

**MEMBERSHIP RENEWAL: IF YOU EXPERIENCE 'MASCOT' PROBLEMS UPON RENEWAL, PLEASE CONTACT THE MEMBERSHIP SECRETARY OR THE TREASURER STRAIGHT AWAY. The Committee**

## © Midget & Sprite Club

# Wheelnut

First of all I must apologise to Andy Knott, my counterpart at *Safety Fast* (MGCC). At the NEC in November, he had taken a rather nice photograph of the MASC stand. I did get his permission to use it in the January issue of *MASCOT* (p.7), but, alas, I didn't credit the photo in print. So apologies for that Andy and thanks for the use of the photo.

If you saw the February edition of *Classics Monthly*, you will have seen that the MASC stand was also the main photograph in its piece on the NEC and *Classics Monthly* has also kindly allowed us to use its "*Sprite Delight*" article covering the restoration of 366 FDB – the Lumbertubs Sprite – which was raced in the '60s.

Continuing our collaboration with other top titles in the Classic Car market, the column on the right was printed in the February issue of *Classic & Sportscar!* I was asked to be in this regular column, I think, as a direct result of my genuine amazement and enthusiasm when *MASCOT* won their award for *Most Improved Club Magazine*. Once again it shows that the major players are more than willing to give our Club both space and recognition which is very gratifying and shows we're definitely going places as we continue through our Jubilee Year.

With the latter in mind, let me remind you there's still a chance to get your hands on one of our commemorative MASC Calendars – celebrating both our 25 Year milestone and the Half-Century of the Sprite. Just have a look at the next page showing the terrific photographs of all the featured Members' cars. How many do you recognise? Just £8.99 from Mike Grout, our Regalia Officer.

So what's in the rest of this month's issue? Well I've already mentioned the *Classics Monthly* article, which begins on page 12; John Davies has come up with a further chapter in his 1st Class series on Early Twin Bore Master Cylinders; Simon Parson has written yet another of his fascinating motorsport accounts- this time competing on the Rally of the Tests in November; Terry has submitted his first major instalment on the History of MASC; and, considering it's winter, yet another bumper-bundle of Area Reports. Keep your excellent contributions coming – by continually improving month-on-month, this is just how *MASCOT* has become an award-winning Club Magazine!

PLEASE NOTE: Deadline for March issue is MIDDAY SUNDAY 10 FEBRUARY.

**Barry**, Editor, 1150, [editor@midgetandspriteclub.co.uk](mailto:editor@midgetandspriteclub.co.uk)

**The statements and opinions expressed in each and every issue of the *MASCOT* are not necessarily the considered views of the Midget and Sprite Club. The views expressed by the editorial contributors, letter writers and advertisers are their own and do not necessarily reflect the view of the Club. The Midget and Sprite Club accepts no responsibility for the results of following contributor's advice, nor does it necessarily endorse the services or products offered by advertisers.**

Front cover picture: Richard Rooks' beautiful Speedwell GT. Originally a UK registered car – 6943MM, it was later exported to the USA. Photo courtesy: R. Rooks.



## Barry Lowe

How the editor of C&S's Most Improved Club Magazine fell for Spridgets

### What attracted you to Spridgets?

When I was about 11, my father had a work colleague who drove a green Sprite Mk1. That memory stayed with me for 25 years and, in 1992, I bought a really nice Speedwell Blue 'Trogey'. It always been a fan of the Innocent 950 Spider – there's a whole chapter devoted to it in Terry Hoiler's *Original Sprites and Midgets* – and in 2001 a superb one came up for sale. Within a week we were the proud owners.

I joined the Midget & Sprite Club soon after I bought the 'Trogey' and became editor of *Mascot* in 2006.

### Which is your favourite event?

The Action Day at Castle Combe. It's my favourite track and gives us the opportunity to spend some time in the Cotswolds with the Spider.

### Your best innocent moment?

Buying our third Coach. They left the factory in three colours – green, white



and red – the same as the Italian flag. Having bought red and white examples, a green one came up for sale in Italy. We had to have it to complete the set.

### Which event are you most

#### looking forward to?

Spridget 50, on 24 May at Gaydon, celebrating 50 years of the Sprite.

### Something to surprise members

I was a DJ for six years.

### If you couldn't have an Innocent?

A 'Trogey' – they're much easier to find parts for.

### And your dream car?

A Ferrari 250GTE – it uses the same V6 (a bit for 'Benzina', 'Glor' and 'Acqua' as our Innocents).



JANUARY

Mo	Tu	We	Th	Fr	Sa	Su
1	2	3	4	5	6	7
8	9	10	11	12	13	14
15	16	17	18	19	20	21
22	23	24	25	26	27	28
29	30	31				



FEBRUARY

Mo	Tu	We	Th	Fr	Sa	Su
1	2	3	4	5	6	7
8	9	10	11	12	13	14
15	16	17	18	19	20	21
22	23	24	25	26	27	28
29	30					



MARCH

Mo	Tu	We	Th	Fr	Sa	Su
1	2	3	4	5	6	7
8	9	10	11	12	13	14
15	16	17	18	19	20	21
22	23	24	25	26	27	28
29	30	31				



APRIL

Mo	Tu	We	Th	Fr	Sa	Su
1	2	3	4	5	6	7
8	9	10	11	12	13	14
15	16	17	18	19	20	21
22	23	24	25	26	27	28
29	30					



MAY

Mo	Tu	We	Th	Fr	Sa	Su
1	2	3	4	5	6	7
8	9	10	11	12	13	14
15	16	17	18	19	20	21
22	23	24	25	26	27	28
29	30	31				



JUNE

Mo	Tu	We	Th	Fr	Sa	Su
1	2	3	4	5	6	7
8	9	10	11	12	13	14
15	16	17	18	19	20	21
22	23	24	25	26	27	28
29	30					



JULY

Mo	Tu	We	Th	Fr	Sa	Su
1	2	3	4	5	6	7
8	9	10	11	12	13	14
15	16	17	18	19	20	21
22	23	24	25	26	27	28
29	30	31				



AUGUST

Mo	Tu	We	Th	Fr	Sa	Su
1	2	3	4	5	6	7
8	9	10	11	12	13	14
15	16	17	18	19	20	21
22	23	24	25	26	27	28
29	30	31				



SEPTEMBER

Mo	Tu	We	Th	Fr	Sa	Su
1	2	3	4	5	6	7
8	9	10	11	12	13	14
15	16	17	18	19	20	21
22	23	24	25	26	27	28
29	30					



OCTOBER

Mo	Tu	We	Th	Fr	Sa	Su
1	2	3	4	5	6	7
8	9	10	11	12	13	14
15	16	17	18	19	20	21
22	23	24	25	26	27	28
29	30	31				



NOVEMBER

Mo	Tu	We	Th	Fr	Sa	Su
1	2	3	4	5	6	7
8	9	10	11	12	13	14
15	16	17	18	19	20	21
22	23	24	25	26	27	28
29	30					



DECEMBER

Mo	Tu	We	Th	Fr	Sa	Su
1	2	3	4	5	6	7
8	9	10	11	12	13	14
15	16	17	18	19	20	21
22	23	24	25	26	27	28
29	30	31				

## ACKNOWLEDGEMENTS

The Molyer & Ayres Club would like to thank the following for their help in producing this calendar:

- **Compliances:** Barry Lowe • **Design & Artwork:** Jonathan Whitehouse-Bird (07736 44435) • **Print:** www.quickprint.co.uk  
 • **Sponsorship:** www.classicinsurances.co.uk • **Photos:** Thanks to everyone who submitted a photograph



# Club Nights

- 1st Monday **London Area** (Congestion Zone) – NEW VENUE, Meet at The Plumbers Arms, 14 Belgrave Street, Belgravia, SW1W 0LN at 7:30pm. Also generally meet at the Ace Café on 2nd Tuesday together with the Classic Cars Magazine night. Details: Gary Lazarus on 020 7700 5696 garylazarus@blueyonder.co.uk
- 1st Wednesday **South Staffs and Birmingham** – Meet at the **The Green Man**, Middleton Village, 8.30-8.45pm
- 1st Thursday **Lincolnshire Area** – Meet at **The White Hart**, Lissington, nr. Wragby. 8pm. Contact Brian Jeffery, Tel: 01522 531425 or mobile, 07952 969514
- 1st Thursday **Notts/Derby border Area** (note change of day) at the Sitwell Arms near Horsley Woodhouse from approx. 8.30. Just a mile north-west of the A608/A609 crossroads. Ian Cooke 0115 938 3838 ilc@bgs.ac.uk
- 1st Saturday **Yorkshire Area** – Contact me, Anita 01423 862738 or 07720 725429 email spridget.girl@ntlworld.com for details of February's meeting.
- 2nd Wednesday **Warwickshire** – Meet at **The Green Dragon**, The Green, Sambourne, Reddich, B96 6NU, at 8.30pm as usual.
- 2nd Wednesday **North West Area** – meet at **The Kilton**, turn off M6 at Jct 20 onto A50 towards Macclesfield. Pub 4 miles on left. Please note new venue.
- 2nd Wednesday **Bristol Area** will meet at **The Rose and Crown**, Pucklechurch at 8pm. All Bristol, Bath and surrounding areas members welcome. Contact Alan Lo on 01179 572617 email: alan@mobuzzing.net
- 2nd Thursday **Cambridgeshire** – Meet at **The Mad Cat** pub in Pidley Village, midway between Huntingdon and Chatteris, 8pm
- 3rd Monday **Dorset** – Meet at **St. Peter's Finger**, Lytchett Minster, Poole 7.30pm
- 3rd Tuesday **Central Scotland** – Meet at **The Garfield Hotel**, Stepps, East Dunbartonshire. 7:30pm in the Lounge. Check first with Carson on 0141-245-6327 day or 013606-22334 evening.
- 3rd Tuesday **Surrey** – Meet at **The Blue Ball**, Walton-on-the-Hill, 7.45pm onwards. Contact Alan Anstead, Tel: 01322 384050. alan.anstead@btopenworld.com
- 3rd Thursday **Sussex** – Meet at **The Friars Oak**, Hassocks, BN6 9NA NEW! from 19.00. Contact Alan Anstead, Tel: 01322 384050. alan.anstead@btopenworld.com
- 4th Thursday **Hampshire** – Meet at **The Poacher**, South Warnborough. Note Change of Venue. Please ring Terry or Harriet Langridge on 01252 626063 for details.
- 4th Sunday **Kent Area** – Meet at **The Moat**, Wrotham Heath at 12:00 for lunch. Contact Alan Anstead, Tel: 01322 384050.
- Last Thursday **Somerset** – Meet at **The Lord Nelson**, Norton-sub-Hamdon. 8.00pm
- Occasional Meetings **Home Counties North West** for members in Herts, Bucks, Berks, N.London or anyone interested! Please contact Chris Jackson Tel: 01707 261567 or Mark Hall, Tel: 01296 660103
- Most Sunday Lunchtimes **Wiltshire** – Meet at **The Spotted Cow**, Marston Meysey

# ***HARDY ENGINEERING***

**COMPLETE RANGE OF GEAR BOXES & DIFFERENTIAL UNITS  
FOR ALL SPRITE & MIDGETS FROM FROGEYE TO  
RUBBER BUMPER HELD IN STOCK.  
EXCHANGE OR OVERHAUL YOUR UNIT.  
NEW AND USED PARTS FROM STOCK.**



**Working with cars like these since the '60s  
actively involved in Club Motorsport at all levels.**

## **SPECIAL SERVICES**

**Competition gearboxes built. Limited slip differential units.**

**Competition crownwheel & pinion**

**3.7, 3.9, 4.22, 4.875**

**HARDY ENGINEERING, 268 Kingston Road,  
Leatherhead, Surrey KT22 7QA**

**Tel: 01372 378927 Fax: 01372 376794**

**Visit our Website at: [www.hardyengineering.com](http://www.hardyengineering.com)**

**Ask for Bill or Neil, Club discount given**

# Club Website

Members Only pages for February,  
User name: Micro Password: Blister

## Events

From David Hill and Webmaster Toby Anscombe

### Events organised for 2008 so far

#### February

Sunday 24th

MG Show at Stoneleigh. Warwickshire Area are organising our Club's participation. Details from Chris Yates, 01608 665066, email: [chrishe@tiscali.co.uk](mailto:chrishe@tiscali.co.uk)

#### March

Friday 14th  
to Sunday 16th

South East Area (Surrey, Sussex and Kent) will be going to the Retro Race Event at Stoneleigh Park. Details from Alan Anstead, Tel: 01322 384050. [alan.anstead@btopenworld.com](mailto:alan.anstead@btopenworld.com)

Sunday 23rd

Kent Area are going to the Medway Festival of Steam and Transport at Chatham Dockyard. Application forms must be returned by 29th February. Details from Bill Fowler 01634 823800

#### April

Sunday 20th  
Monday 21st

Kent meeting brought forward to coincide with "Drive it Day"

A Gathering at the Lamb Inn, Iron Acton, near Bristol, to mark the 25th anniversary of the very first meeting that led to the formation of the MASC. More info in this *MASCOT*.

Saturday 26th  
& Sunday 27th

Warwickshire Area's Green Dragon Run. Details from Chris and Sheila Yates 01608 665066, email: [chrishe@tiscali.co.uk](mailto:chrishe@tiscali.co.uk)

#### May

Saturday 3rd  
To Tuesday 6th  
Saturday 10th

Surrey Area Annual Tour. New Forest. Details from Sue Judd. [suej001@btinternet.com](mailto:suej001@btinternet.com) or Chris Harding, [harding.c@btconnect.com](mailto:harding.c@btconnect.com)

Droitwich Motor Festival. Warwickshire Area will be there, details from Roy Cole, 01562 885766 email: [roy@geraldineandroy.co.uk](mailto:roy@geraldineandroy.co.uk)

Friday 16th  
To Sunday 18th  
Saturday 24th

International Healey Weekend at Goodwood.

Spridget 50 at Gaydon – The Big Party. To register an expression of interest and receive priority booking, please contact Jeremy Cogman on 07702 958450 or email: [organiser@spridget50.com](mailto:organiser@spridget50.com)

Sunday 25th

Kent Meeting cancelled due to Spridget 50

#### June

Thursday 12th  
To Sunday 15th  
Saturday 14th

Surrey Area's D-Day Beaches Tour.

Castle Combe's Classic and Sportscar Action Day. See *MASCOT* or contact Terry Horler. 01454 881770

Friday 13th  
To Sunday 15th

Spridget Effen (MASC Germany), Pfronten, Germany. Contact Jim Willis on 01527 402804 or email: [jim.willis@tiscali.co.uk](mailto:jim.willis@tiscali.co.uk) if you are interested to go.

## July

- Sunday 6th Warwickshire Area's Worcester/Shropshire Run. Details from Roy Cole, 01562 885766 or email: roy@geraldineandroy.co.uk
- Tuesday 8th  
To Tuesday 15th Surrey Area's Le Mans Tour. Sorry, now fully booked.
- Friday 11th  
To Sunday 13th Goodwood Festival of Speed. www.goodwood.co.uk
- Sunday 20th Warwickshire Area's Hereford Hop. Details from Phil and Mo Wood, 01905 456303 or email: philipwood@btinternet.com
- Friday 25th  
To Sunday 27th Cambridgeshire Area are going to Silverstone Classic Meeting. Details from Hubie Albany on 01733 265548
- Sunday 27th Kent meeting at Cliftonville Car Show, Margate, Kent. Needs to be prebooked. Details from Alan Anstead, Tel: 01322 384050. alan.anstead@btopenworld.com

## August

- Saturday 9th  
& Sunday 10th Warwickshire Area's Ireland Trip. Details from Alan Couch, 01564 773302 or email: roalan@talktalk.net
- Thursday 21st  
To Sunday 24th 10th International MG Meeting in Berlin. Information and registration see www.mg-club-berlin.de or fax 0049-3084-707204 or Tel: 0049-3084-728381

## September

- Saturday 6th Warwickshire's Mike and Benitas' Fun Day. Details from Mike and Benita Vann, 01455 292440 or email: Michael@mvann.wanadoo.co.uk
- Sunday 7th Coventry Motoring Festival. Warwickshire Area will be there. Details from Dave Colclough, 02476 677897 or email: david@colcloughsonline.co.uk
- Friday 19th  
To Sunday 21st Goodwood Revival Meeting. www.goodwood.co.uk

## November

- Friday 14th  
To Sunday 16th Classic Car Show at the NEC.

## December

- Wednesday 10th Warwickshire Area's Christmas Dinner at The Green Dragon. Details from Sheila Yates, 01608 665066 or email: chrishe@tiscali.co.uk
- Tuesday 16th Kent/Surrey/Sussex Area's Christmas Meal. No other area meetings this month.

Area Reps please let David Hill (email: david@hillnet.clara.net) have confirmed dates for new events asap.

Remember there are Club Night Natters throughout the year and that area events are also open to members from other areas!

Please also note that the above lists only M&SC events or events where we have a presence or an interest. General classic events are listed in the classic press.

# Result of Ballot for Treasurer

Thanks to all returning their Ballot forms to formally elect Anita Lachowicz to the position of Treasurer. The results were as follows -

In Favour 79 votes      Not in Favour 16 votes

Our thanks to our independent adjudicator, Mr M. Helbrow for collating the results.

# Mutual Assistance Directory

Well, the coming summer season is shaping up to be a really great year. The Areas have been active in getting together a fantastic programme of events and with 2008 being the 50th celebrations, there is no excuse not to get out and about. Hopefully you will not need the help of a fellow member but if you do, we are just a phone call away!

Just a thought but has anyone done a breakdown of breakdowns! Do we have any statistics for the most common cause of breakdowns? Maybe if we knew that, say, ignition troubles caused 70% of breakdowns,

we could take steps to minimise the likelihood of this in our cars. Does anyone have any thoughts on this?

Don't forget, if you don't carry your copy of the Mutual Assistance Directory and you would like a copy you can download it from the members only section of our website. However, if you do not have access to the web or don't know someone who does, I will print off a copy and send it to you. Please remember that it is constantly updated so to be up to date, download it at least every month.

**David Hill**

## New Members

**We extend a warm welcome to the following new and rejoined members**

3952	Ken and Pauline Cooper	West Midlands	Frogeye
3953	Anon		
3954	Andrew Bird and Jeanette Bowron	West Midlands	Frogeye
3955	Richard Wheeler	Essex	Sprite Mk 3
3956	Peter Harley	Nottinghamshire	Midget Mk 2
3957	Denis and Margaret Bowley	Berkshire	Midget Mk 2

## Message from the Chair

For those of you who have not heard, Anita Lachowicz, the Club's Treasurer, and Mark Boldry were injured in a car accident last week. Anita sustained some serious injuries including a broken pelvis and will be out of action for quite a while. I'm sure the Membership would like to join the Committee in sending their best wishes to Mark and Anita for a speedy recovery. Unfortunately this incident does impact on the Club's progress towards becoming a Limited Company as we need the accounts audited before the old Club can be dissolved. Congratulations are in order as Anita has retained her position as Treasurer in the recent ballot. Perhaps this good news will aid her recovery.

On a slightly different note I have recently been required to vacate a garage I rented from the local council. It was full of old bits of Midget collected over the years, wings, bonnets, front suspensions, windscreens, bumpers, all sorts. Having no where else to

put many of these things some tough decisions had to be made, what to keep. While sorting through this pile of stuff it came to me how times have changed. Back in the day when I first acquired my Midget, you couldn't buy many new spares at all. A few things appeared at autojumbles when some old garage closed down but that was about it, apart from engine parts like pistons and bearings, and that was only because there were lots of Morris Minors and Minis around. So you hung onto anything that came your way, just in case. The only body panels available were sills and repair sections made by enthusiasts like Ashley Hinton, a staunch supporter of the Club for many years. Now you can buy complete body shells and enough parts to make a new car! So most of the old stuff went to the great scrap yard in the sky, or the local recycling centre as it is now known. The premise being I can always buy new.

Happy motoring

**Nigel Williams, Chair**

# The Key to low cost insurance

for Midget and Sprite Club members



Don't pay more than you have to for quality insurance cover. Adrian Flux have great insurance deals for Midget and Sprite Club members. What's more they offer excellent service and competitive prices too.



## 0800 089 0035

**QuoteLine Hours:**

Mon to Fri 9am-7pm

Sat 9am-4pm

email: [quotes@adrianflux.co.uk](mailto:quotes@adrianflux.co.uk)



[www.adrianflux.co.uk](http://www.adrianflux.co.uk)

Authorised and Regulated by the  
Financial Services Authority



**ADRIAN FLUX**

modern approach, traditional values

# Early Twin bore Master Cylinders: Part 3

This is a *second* postscript to my recent article about twin bore master cylinders (*MASCOT* October 2007, page 10). The first postscript (*MASCOT* January 2008, page 14) was written after receiving important information about the length of the pushrods from Ray English in Australia. This second postscript is a result of extra information from America, received after Ray reprinted my original article in his magazine *Marque One*.

After reading the reprinted article, Frogeye owner Mike MacLean in California wrote immediately to Ray English, informing him that Joe Way in California – with advice from Gerard Chateauvieux in San Francisco – has manufactured custom  $\frac{3}{4}$ " pistons and standard  $\frac{3}{4}$ " pushrods (items 12 and 19 in Figure 1). Joe can supply fully reconditioned units of extremely high quality to suit the individual needs of each customer. His company (Sierra Specialty Automotive) and Gerard each have excellent websites ...

<http://www.brakecylinder.com/spridgetbrakes.htm>

<http://www.gerardsgarage.com/>

... and both are recommended reading for anyone who is about to restore one of these early master cylinder units. To my astonishment – and I think to Ray English's

astonishment as well – Joe has actually built and supplied the mixed bore cylinders that were only imagined in my original article. Joe's units are illustrated in Figure 2. The unit on the left is sized for drum brakes and  $\frac{7}{4}$ " (1098cc) clutch; the one in the middle is for standard *GAN2/3* and *HAN7/8* cars (disk brakes and  $\frac{7}{4}$ " clutch); the one on the right is for disk brakes and  $\frac{6}{4}$ " (948cc) clutch. The left unit is suitable only if a later  $\frac{7}{4}$ " clutch is installed with a 948cc engine: drum brakes are only just adequate for this early engine and with a larger engine in modern traffic, this left arrangement would almost certainly provide inadequate (unsafe) braking. The middle unit is also suitable for the popular conversion which places a complete 1275cc engine, gearbox and clutch in an early front disk braked car (an arrangement which uses a *different* clutch slave pushrod than that used in the 948cc and 1098cc cars!).

In my original article I tried to stress the importance of matching all brake components. The difference between a  $\frac{3}{4}$ " and  $\frac{7}{8}$ " bore does not look great (see Figure 2). Many people have ignored this difference and been tempted to use the freely available  $\frac{7}{8}$ " unit with disk brakes. In his website, Joe has explained the dangers of this practice much more clearly than I have done, by calculating the extra

pedal effort required if the large bore is used with disk brakes: this depends on the relative cross sectional areas of the two pistons (and so depends upon the ratio of the *squares* of the piston radii). Expressed as a percentage, this is ...

$$\begin{aligned} & \left[ \left( \frac{7}{8} \right)^2 / \left( \frac{3}{4} \right)^2 \right] \times 100 \\ & = \left[ \left( \frac{28}{24} \right)^2 \right] \times 100 \\ & = 136\% \end{aligned}$$

i.e. 36% more pedal effort!  
As Joe points out, this constitutes a significant safety and driveability issue. I repeat here what I stated in my original article:  
Abingdon never changed

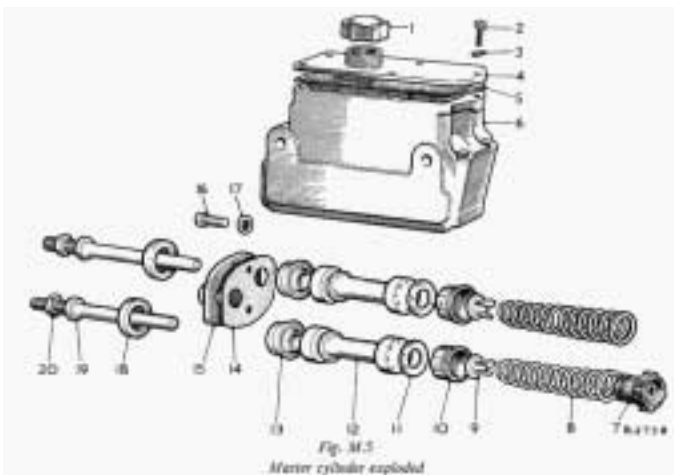

Figure 1



Figure 2  
(photo courtesy of Sierra Specialty Automotive)

brake components unless there was a very good engineering reason for the change. This same statement also applies to the clutch components: if an early  $\frac{7}{8}$ " master cylinder clutch bore is used with a later  $7\frac{1}{4}$ " clutch, the result will be a 'harder' clutch which is difficult to engage smoothly and which requires 36% more than the factory-optimum pedal effort.

Joe also suggests a much more convincing reason for the shorter  $\frac{3}{4}$ " pushrods ... "as the  $\frac{3}{4}$ " piston is smaller in diameter, the pushrod socket is also smaller in diameter, by about  $\frac{1}{16}$ ", and there is less room for the up-and-down articulating motion of the pushrod as the pedal is depressed. If the socket were drilled deeper to receive the longer pushrod, the pushrod would bear against the bottom of the socket as the pedal is depressed."

To complete the story, Joe also points out that the  $\frac{7}{8}$ " and  $\frac{3}{4}$ " brake bores require different



Figure 3

return springs, spring retainers and brake check valves (items 8, 9, 7 in Figure 1). The major diameters and the spring rates of the  $\frac{7}{8}$ " and  $\frac{3}{4}$ " springs are similar (see Figure 3) but the 'bottom' of the  $\frac{3}{4}$ " spring is larger, to accommodate the plastic check valve body which *must* be used with front disk brakes (as the early metal check valve *must* be used with all-drum brakes). According to Joe, a  $\frac{7}{8}$ " spring will work perfectly in a  $\frac{3}{4}$ " clutch-side bore but it will not work in a  $\frac{3}{4}$ " brake-side bore without a slight modification which he describes in his website. Joe can supply new or very good used  $\frac{3}{4}$ " springs and is able to supply a custom unit that will operate brakes and clutch with exactly the same pedal feel and system performance that was present in the original cars.

In the Southern Hemisphere, Tony Bennetto at The Bugeye Barn in Ferntree Gully, Victoria has also manufactured the  $\frac{3}{4}$ " pistons and can also supply excellent fully reconditioned  $\frac{3}{4}$ " units. For more details, see his website ...

[http://www.bugeyebarn.com/html/s01\\_home/home.asp?dsb=1](http://www.bugeyebarn.com/html/s01_home/home.asp?dsb=1)

To sum up, high quality new and reconditioned  $\frac{3}{4}$ " master cylinder units are available from three independent companies in three different countries ("Past Parts" in Britain, "The Bugeye Barn" in Australia and "Sierra Specialty Automotive" in America). Upon reflection this is perhaps not too surprising because most of Abingdon's output went to one or other of these three places. Nor is it too surprising that the Americans have already made the mixed bore cylinders that I only imagined in my original article. After all, America did put a man on the Moon in 1969 when Abingdon workers were still pushing Spridgets down the factory line by hand, using the assembly techniques of the 1930s ...

I thank Ray English (Editor, *Marque One*), Mike MacLean, Gerard Chateauvieux and Joe Way who all read and checked my manuscript at short notice and provided valuable extra information. I also thank Joe Way (again) for permission to include Figure 2. Any errors remaining are mine.

**John E. Davies**  
(Member 3443)  
jed2@cus.cam.ac.uk



# Sprite Delight

It was almost 50 years ago that the works Sprites dominated their class at Sebring, but their following is as strong as ever...

**D**ave Owen has owned several Sprites over the years and has become more passionate about them as time's gone by. Reading about the successful racing exploits of the Sebring Sprites during the 1960s really whetted his appetite for owning one. It's believed that only five or six were ever built, so securing one of the originals was almost out of the question. However, the Sebring Sprite formula was to become quite a popular contemporary

modification, which spawned a number of cars built to homologation rules for club racing. These cars were ostensibly period copies of the Sebrings rather than the more modern-day replicas. It was one of these cars that Dave managed to acquire for restoration.

Dave's Sebring Sprite started life as a humble Progresso, and a short while later was rebuilt to Sebring specification by privateers Brian and Ken Myers in Northampton. They lived in Lamberts

Lane, and this car has since been colloquially referred to as Healey Sprite circles as the Lamberts' Sprite.

Modifications included fitting a GRP front end, which was made by Williams and Pritchard – who fabricated the original Sebring Sprites. The Berlinese coupé roof was hand-crafted in aluminium by Alan Thompson, an Aston Martin employee, and is grafted onto the original steel bodywork. The drum brakes at the front are Austin A40

Above:  
Dave Owen has done a superb job restoring his Sprite to its former glory.

# The Resto

Dave's Sprite was in a bad way when previous owner Paul Woolmer got his hands on it. Paul kept the car for two years before finally giving it to the pressure and asking it to Dave. It just goes to show that if you really want something badly and it's in limited supply, it's sometimes you have to dig deep into your pockets. Many generally talk all kinds of language! The

restoration took four years from start to finish, and Dave says that fitting the glass was by far the most difficult part of the project. He's to be congratulated on doing as much of the work himself, especially the engine, but he acknowledges that for certain things, specialist help was invaluable. Genuine Sprites have got impeccable race history, but Dave's makes for a great road car.



▲ Dave purchased the Sebring in December 2000 and when he first saw the car it was virtually a bare rolling shell, sans engine and still sitting on the wide cut and shut steel wheels.



▲ Paul Woolmer had completed a small amount of restorative work, which had centred around getting the bodywork sandblasted in readiness for the bodywork repairs.



▲ The floor was in a particularly bad way. Having been neglected for so long, it was the usual story of the bottom three inches of the car being non-existent.



units and larger than the standard Froggye set-up, although the normal Sebring mod was Girling disc brakes.

## Competition history

The Myers brothers raced the Sprite up until around 1966-67, after which it transferred into the ownership of their racing partner Peter Webster, who replaced the 998cc Formula Junior engine with a 1650cc Ford engine. That was followed by a 1488cc Cosworth in the late 1960s, and Webster sprinted the car with plenty of success. It lost much of its Sebring shape and became more MidSports, with the wheelarches cut out, the steel wheels cut in half and

widened using a steel burs to six inches at the front and eight inches at the back, and it also acquired a bonnet bulge to accommodate the new engine.

Dave first saw the car when it was featured in a book called *Sprightly Years* by John Sprinzel and Tom Coulthard—which is now out of print; copies can change hands for several hundred pounds—and instantly fell in love with it. There was a black and white photograph taken when it had turned up in the 1990s after many years of storage and the car looked a tad sorry for itself.

"The Sebring was recognised by one of the Hooley Club officials, Paul Woolmer, as the Lumberlugs Sprite. It

## History of the Sprite

The Sebring Sprite was conceived by enthusiast and racer John Spritzer, who previously been involved with another special-bodied Sprite, the Speedwell GT. He'd been associated with Sprites since 1956, and following the success of Healey-Sprite at Sebring in Florida, a plan was formulated to build a lightweight car with improved aerodynamics – hence the aluminum chassis and GPR front end. A number of other cars were also produced by Paul Coachworks.

Three Sebring Sprites were entered for the 12-Hour race at Sebring on March 12, 1959. All three cars completed the distance and took a commanding class win, finishing first, second and third.

John Spritzer drove his Sebring Sprite, registered PH-52216, in the 1960 RAC Rally where it was almost second overall. Stoting Moss raced the car at Sebring in 1961 and it was entered on the Monte Carlo Rally in 1962 by John Spritzer, with co-driver Christopher Cannon.

Several of the original Sebring Sprites are still around today. 41D EAO, originally raced by Andrew Hedger, is now owned by Richard Whitehouse-Rad and is being restored. WBR 707, driven by Ian Walker in the early 1960s, is now owned by Stephen Brown and being restored. The remains of John Spritzer's old car, PHD 200, have now been restored by Paul Woodcock. 3221, originally owned by Cyril Larson, is now owned by Chris Diego. Another car, originally registered WBR 727 and then re-registered 030 by David Segie Morris, seems to have disappeared.



### AMERICAN DREAM

The Sebring name comes from the famous American 400-mile, home to the annual 12-hour sports car race. In 1959, it also hosted the first Formula One American Grand Prix.

(which had disappeared after about 1974 having been owned by Anthony Smart and presumably used as a road car) and he subsequently purchased it," Dave explains. "I contacted Paul Woodcock to see if he'd sell me the car, but for about two years he wasn't interested. However, he had another Sprite project lined up and eventually succumbed to selling me the car after I made him an offer he couldn't refuse."

### Cosmetic surgery

"The body wasn't too badly rotted," says Dave. "Most of the repair work would be to the floor pans and sills. While the car had obviously been much modified in the past, luckily the bodywork had never been messed with, which made things straightforward and there weren't any horror stories lurking undiscovered."

"I spent quite a bit of time deliberating over how I wanted to rebuild the car, and whether it should take the guise of an original Sebring Sprite with a

1980cc Formula Junior engine. I asked many enthusiasts in club circles and was advised against going for a 998cc engine because getting one rebuilt and running powerfully and properly was going to be very expensive. I decided to go the route that everyone else does by running a 1275cc A-series engine."

Work got underway in the spring of 2000. The Sebring was placed on trestles in Dave's double garage and he tackled the bodywork repairs. It was really a straightforward Sprite rebuild and all the replacement parts required are readily available.

### Getting under the skin

Dave hadn't done a massive amount of welding before, so it was a slow process of learning as he went along.

"I cut the inner and outer sills off one side and then welded in brand new sills," he explains. "I then welded in a new floorpan on the same side. It's complete and runs from the front to the back of the car and I repeated the process on the other side."

"One of the weak points on the Sprite that are very expensive to repair





## "Throughout the restoration I wanted to conserve as much as possible"

are the quarter elliptic spring hangers. If the hanger rots then it's a major problem, partly because you lose all your reference points. If it's in the wrong place, the axle alignment will be wrong. Fortunately, mine were sound."

New aluminum inner front wheel arches were specially made by Brian Wheeler, well known in Healey circles for supplying replacement parts.

The rest of the body was in remarkably good condition but the GRP one-piece front end of the car was in a terrible state having suffered from star crazing. There was also a crack in it. The latter was relatively simple to repair, but Dave spent the best part of three weeks carefully grinding out all the crazing and rebuilding the fiberglass with new material. It proved fine for about 18 months, after which it started to come through again.

"Sometimes you can't really repair everything on an old GRP, but I didn't want to discard the front end and replace it with a reproduction one," says Dave.

"It's very much part of the integrity of the original car and throughout the entire restoration I wanted to conserve as much as possible, with the exception of some of the rusting gear."

### DIY delight

Dave had done a little bit of respraying before, but not a whole car. He never considered having his car professionally painted, though.

"I wanted to complete as much restorative work in the car as possible, and just about the only work entrusted

to specialists that I didn't feel capable of completing properly was the engine and gearbox rebuild," he admits. "I even had a crack at making a new rear Polycarbonate screen and side windows using the old ones as templates. Making the rear screen was a doddle, but replacing the front one was a nightmare! I'd been led to believe that it was from an Aston Martin DB2/4, possibly because the roof had been made and grafted in by an Aston Martin employee. The old screen had slightly yellowed, had one stone chip and was usable, but when putting it back in I managed to break it."

As things turned out, though, Dave discovered that the old screen wasn't from an Aston Martin after all – what to do now? He spent three months trying everything he knew to establish its origins, but all to no avail. Having now reached the end of his tether, he struck lucky via the internet and contacted Ricky Evans Motorsport, a company specializing in heated screens. Ricky found that the screen had been cut out of another car and very kindly tried to source another screen. He did, but broke it during cutting it to size...

In desperation, Dave contacted a glass company with a view to getting a screen specially made, which was extremely expensive and then they wanted to make a minimum run of 10! Ricky was also on a mission of his own by now and managed to persuade Triplex to make a one-off screen for the Sebring. It cost £600 and they've kept the mould in case Dave ever wants a replacement. "This was by far the worst experience of the



▲ "The transmission tunnels on Sprites only need replacing," explains Dave, "thanks to being well preserved by oil that's thinned back from the original."



▲ The strength of the shell comes from the floor and pillars, so Dave braced the door apertures and honed his welding skills, replacing everything involved.



▲ The temporary door brace can be seen here. Other areas to need attention were the boxes of the A-pillars. Again, Dave cut them out and welded in new sections.



▲ Ironically, Dave completed the spray of the car in his garage at home. The body was silt-primed and then finished in British Racing Green using cellulose paint.

## Engine Spec & Mechanical Overview

The original Sebring Sprites were prepared for the 1959-12 four-year by Geoff Howley. The cars featured disc brakes all round, as well as a slightly larger 1.25-inch SU carburettor. When Dave came to restore his replica, he decided against an original-spec 1963 engine because of the prohibitive costs. Instead, he fitted a 1300cc unit that's been tweaked by Surfline.



### 1963 Sebring Sprite

**ENGINE** 1300cc DMV in-line four 4-cylinder, 11-valve head with ARP bolts, fully ported and jet floored, valved chambers, Lucas valve guides, special cast iron angle headfire valves, Swiflow double valve springs, 1.5 roller to rollers, 4500CC Weber A165 Red Cup #2300 carburettor, Lucas-style electronic ignition, Lucas electric fuel pump, aluminum radiator

**POWER** 120bhp @ 5500rpm, fuel engine is redlined at 7200rpm

**DRIVETRAIN** Engine not yet been an Apsis

**TRANSMISSION** Four-speed manual close-ratio straight-cut gearbox

**SUSPENSION** Front coil and struts, 50 per cent capped lower arm dampers, anti-roll bar. Rear sports elliptical leaf springs, Spax adjustable telescopic dampers, has axle located by Kwik-lub axle. Quads 3.71 150

**BRAKES** Front discs, rear drums

**WHEELS** 4.5x11 steel

**TYRES** 195x11 13-inch

**0-60 MPH** 7 seconds with 1.1 1.400  
1.4 seconds with 1.5 1.400

**TOP SPEED** in excess of 120mph with 1.1 1.400



### PLAYING IT SAFE

Being intended as a competition car, one of the safety additions Dave fitted to the Sprite was an optional car-coil master switch.



**"It's basic engineering and most things can be rebuilt"**

The right fit's such a pretty car that it's no wonder many Sprites were converted to Sebring spec. Instead, A Swiflow 1300cc Apsis engine has been fitted rather than the original 990cc unit.

entire restoration," he says, "but all's well that ends well I guess."

The rear brakes are slightly different to standard Sprite units and are 8-inch drums that come from a Riley 1.5, which is a standard Sebring modification and was omitted here.

Sebring Sprites also feature a different pedal box set-up from standard cars and use Girling cylinders. Harley specialist

Acher's Garage were able to supply all the parts necessary to rebuild the box. The back axle was rebuilt and initially fitted with a 4.5:1 LSD, which would easily spin the wheels in any gear. This was later changed to 3.7:1 for more practical road use. Up-rated halfshafts were also fitted.

### User-friendly classic

"One of the things I like about the Sprite is that it's basic engineering and most things can be rebuilt," Dave points out. "Even the original Lucas electric switches were stripped down and rebuilt. While the car did come with a gearbox, I don't think it was the original, so I sourced another with close-ratio straight-cut gears, which is the most desirable for my car, and had it rebuilt by Hardy Engineering in Surrey."

The engine was missing when Dave acquired the car, so he sourced a 1275cc unit and entrusted Swiflow in Kent to work their magic on it. They built it to their Road Rocket specification; it's all been lightened and balanced and the block's been bored out to 1300cc. A fast road carburettor was put in, along with a 4500CC Weber carb, an LCD exhaust and a 1.794-inch straight-through Muntlow system.

The original safety equipment in his car included what Dave says assembled





gas pipe for a roll cage, but he fitted a Safety Devices cage made specially for the Sprite. It was a bit of a gamble as to whether he could get it inside. It was a tight fit, but he just squeezed in – though not before he managed to put a ding in the aluminium roof! The GRP Sebring bucket seats were trimmed in leather and supplied by Archer's Garage. Like three-point harnesses and a fire extinguisher were also added – essential equipment in a competition car.

The dashboard has been rebuilt using instruments mostly from the Mk2 Sprite, including a rev counter that Dave has recalibrated and rebuilt fitting his own internal electronics. He's an electronics engineer by profession, so tackling the car's revise and electrical system was a cinch for him. Everything's now fused separately and wired correctly. He also loves electronic gadgets and has fitted a Race Technology data logger, which, when plugged into a laptop, can reveal a whole host of information on how the car's performing on the track.

#### Time well spent

The restoration took four years to complete and Dave's naturally delighted with the finished car. It's something of an irony for him, but having invested a considerable amount of money he now feels uncomfortable about racing it. With

all the inherent risks of competition, he doesn't want his pride and joy getting damaged. However, he does drive the car on the road as often as possible. He did find that in summer the cockpit became unbearably hot, so he cut two holes in the roof and fitted plastic vents. He then fabricated a GRP cow, which provides additional cooling air.

Another later modification was to fit adjustable telescopic dampers at the rear to soften things up, while things are much stiffer at the front. "The car now corners and handles much better with this set-up and you can hang the tail out for as long as you like, providing you keep the power coming in," enthuses Dave. His car has accumulated an interesting history and race provenance, something you simply can't go out and buy – it's got to be strived for and won. It's as close as he can get to one of the original handful of Sebring Sprites built, and has been beautifully restored.

#### Dave would like to thank:

Brian Archer of Archer's Garage for seats and specialised Sebring parts; Brian Wheeler at Wheeler-Davies; Colin at Progress Spaces Co for alloy radiance and body repair panels; Nick Swift at Swiftbars; Hardy Engineering; Ricky Evans of Ricky Evans Motorsport; www.sebringsprite.com for historical info.

## Restoration | Sebring Sprite



▲ When it came to refurbishing the Sebring's running gear, Dave replaced the front brake drum set-up for discs, a wise move considering the engine was being modified.



▲ The front and rear suspension was rebuilt, using new king pins at the front that are larger than standard with the disc brakes. The lower arm dampers were also rebuilt.



▲ To keep everything nice and cool, Dave abandoned the original radiator in favour of a larger aluminium one, which has proved up to the job.

### TELL US YOUR STORY & WIN A YEAR'S FREE SUBSCRIPTION



Do you have a restoration story? Then CLASSICS MONTHLY would love to hear from you. Email us at [classicmonthly@btinternet.co.uk](mailto:classicmonthly@btinternet.co.uk), or write to CLASSICS MONTHLY, 30 Mooncreek Street, Bath BA1 2BW. Include sample photos. You must have photos of the restoration as it progressed. If your completed photo is featured, we'll photograph it professionally for the finished article.



## Testing Times for the Yellow Peril

As usual Fred Bent had plenty up his sleeve to tax those of us competing on the Classic Rally Association's Rally of the Tests (1-4 November, 2007). The Northern coast-to-coast route also meant that Fred had ample local knowledge, especially as we got closer to his native Lancashire. The start was in Scarborough, and as the lady Mayoress hinted at dinner, it might be not quite as popular as its West Coast cousin, but it's much nicer!

After a long day of plotting on the maps for my navigator Trevor and a lot of thumb twiddling for me it was up to the Oliver's Mount race circuit for a short night regularity section to start things off. The route was designed to catch out the unwary, and sure enough we missed a turn and ended up doing a lap too many and so began the long trip West with a minute penalty and in 31st place. I did better on the first short test on the front, but not as

well as the Imp of the Edgington's which was flying and would continue to set fastest times of the day (FTD) on many tests until the gearbox gave up. We were in the 'Yellow peril' 1970 Austin Healey Sprite, accompanied by just one other Spridget; the 1275-engines Frogeye of Jocelyn Williams and Janet Lloyd-Jones.

Saturday morning took us out to Sledmere Hall in the Yorkshire Wolds to get things underway with a short regularity around the grounds. The day went smoothly from here as we visited familiar test venues at Tockwith, Rufforth and Lightwater Valley and were cheered along by friendly faces from the local motor clubs. Posted ideal times for the regularity sections showed that we were on the button and had lost only a handful of seconds. My test times seemed respectable, but that Imp was giving everyone a good beating. Croft circuit offered a couple of very fast tests which

I really enjoyed and then we headed west towards Swaledale. A long, muddy test with lots of solid obstacles at Bolton Hall really suited me and only a Dutch 911 pushed us into second place. The final regularity of the day was a tight run in the dark, with a cunningly placed time control just after a difficult farmyard which caught out several crews. One of the marshals pointed out that I had a headlight out, so when we arrived at Tan Hill for the supper halt I had to re-earth one and then the other headlight in the car park watched over by a hungry Swaledale sheep. I just had time for some of Trevor's leftover Yorkshire pudding with sausage before we were off to the dreaded Warcop army camp, where we had been warned of killer concrete tank ramps and the likelihood of never finding your way out if you wrong slotted. In reality it was great fun with timed to the minute sections from instructions driven flat out on a mixture of gravel, broken and solid tarmac. To add to the fun there were multiple, overlapping circuits to complete, so at many junctions the cars ahead and behind might go in different directions, but you could all be right! We stayed on the straight and narrow apart from a rather large 'moment' when I nearly introduced the Sprite to a tree after the Alvis Speed 25 of Bill Ainscough and Catriona Rings let us squeeze past.

The night halt was short run away in Penrith and I managed a repair-free night in the bar watching the navigators plotting and hypothesising over increasingly conspiratorial route issues. We had crept up to 14th overnight and therefore had a bit of a lie-in as the field was running in reverse order.

Next morning saw us on a test at tiny Carlisle airport and then began to head north across the border and into Dumfries and Galloway. The weather remained unseasonably warm, but clear and dry, so we were pleased to keep up our tradition of 'open running' for the majority of the event. A difficult regularity section at Dundrennan army camp was a jogularity for the most part, but then the last 5 miles had no intermediate split times so a sudden switch to regularity timing was called for. Looking at the results later showed that this final section had caught out more than a few crews and almost no one had single figure penalties.

The day progressed with great regularities and tests in the Dumfriesshire hills, one memorable pair of tests had us slithering around an off road circuit on alternating 30-second start slots. I was quick here and just missed out on FTD to that Porsche. Last test of the day was a loose, uphill blast on a farm track after a few circuits of some cones to keep the average speed down. It was just dusk, and we had skipped petrol to make it before dark fell. This proved a good decision as we set FTD on this one, just equalled by a hard-charging Irish Volvo PV544. Next up was the final night section, a mixture of yellows and forest sections in Kershope forest, which looked like fun. We were both up for it and set off flat out, difficult sections began to flow and we achieved that rare state (for us at least) when you are both 'on it', the navigator is calling perfectly, the driver has complete confidence, you're going very quickly and calm descends. Then we rounded a gravel bend and met the tail of the Macleans in their venerable Rover P4 100. Ahead of them it was chaos; a Vauxhall VX 4/90 was being towed out of a ditch by the Frogeye Sprite of all things, behind this were at least another 4 cars heading towards us. Pretty soon cars started to appear behind us on the narrow forest road with deep ditches to each side and I knew that any hope of a good finish on the rally was lost. We were being asked to turn around because a 'no' (wrong way) board had been found, we knew we were right, but it took a lot of convincing to get the others to turn around and head off in, what was, the correct direction. Eventually we blasted off, but were 7 minutes late into the next control. Undaunted we pressed on, passing a couple of cars and then tailing the Frogeye of Jocelyn and Jan in their matching black wigs and blue bomber jackets. We had just commented on how well they were going when they shot off the gravel and into a very deep ditch! We stopped to check they were OK and that the smoke was steam from the boggy ditch bottom and nothing more serious. There was no way we could get them out, so we pressed on (but I did fix the exhaust on their car later that night to make up for it). I don't think I've ever had as much fun on a section as this one. We got back on our minute, negotiated a difficult sloping grass triangle where the genial Tony Mason (ex Top Gear) was ready to tell us off



for not stopping at a give way line and then we started arriving early at checkpoints. We passed Kenny and Jane MacEwan in their Sunbeam Harrington then I noticed that the battery wasn't charging so we completed the last couple of sections without spotlights which increased the excitement level a bit. Of course that meant straight under the bonnet when we got back to Penrith. The alternator was at fault, so I took it out, found a sticking brush, freed and replaced it but no better. I sent Trevor into the hotel to find a spare, the first one was wrong-handed and wouldn't swap, so he found another which a TR4 had brought along after unearthing it in the navigator's brother's garage before the event. Wrong-handed but this time it would swap. I fitted this one after various altercations with the mounting bracket and we were back in business. Throughout, a group of keen supporters from Wigton MC kept us amused and offered a hand where possible while Peter and Betty Banham were doing sterling service fixing several cars whose owners had disappeared to the bar. Andy Inskip was still out pulling cars from ditches so I asked Peter if he needed a hand. One Porsche 356 regulator, a Frogeye exhaust and an MGB fuel pipe later at 1:45am I was excused to go to bed. Next morning we had dropped to 20th after the troubles in the forest, but it was off to a beautiful test at Lowther estate where we encountered a red deer stag on the tarmac, which fortunately chose to jump the right way when I beeped the horn and then we caught a Dutch Alfa Guilieta on the line after they'd had an excursion onto the lawn. We returned to Warcop, but this time it was a regularity

section on an extract from an old 1' map of the area. I recognised a few features, but it was tough. The gravel sections were slightly easier in the light but no less enjoyable. We got the right route and only dropped seconds here and there which was to prove better than many crews.

The final day was a run through the Howgill fells to Sedbergh and then diagonally across to Blackpool. Farmyard tests, car parks and stately homes flowed and we set a few good times, coupled with solid, single figure performances on the regularities meant that we were hoping to keep our position of second in class behind the Kirkham and Haselden Mini Cooper. One test saw us rolling downhill into a box before starting the engine and blasting across a (dry) ford and then up a steep hill to the timing point. This proved too much for the big Citroen DS of Warren and Jean Chmura, which loses suspension and steering when the engine is off, so they had to take a maximum. A slow crawl up the unbelievably gaudy promenade in Blackpool, lead us to the final test on the front. Tight cones where I picked up my only cone fault of the event and a finish where the navigator had to leap out and ring a bell brought a fitting end to an excellent event. We had climbed a little up to 18th and second in class at the dinner that night which rounded off a great weekend that I'd recommend to anyone.

Go to <http://www.classicrally.org.uk/> for full results from the Rally of the Tests, and <http://www.tonylarge.co.uk>, for more pictures of the Rally of the Tests

**Simon Parson**

# GET IN THE RIGHT GEAR

for

# SPRIDGET 50



# THE BIG PARTY

To celebrate 50 years of the Austin Healey Sprite and the MG Midget, and to coincide with SPRIDGET 50 - THE BIG PARTY, a range of regalia items have been specially produced for this unique event.

All items listed feature the logo shown below and include:



<b>Tee Shirts</b>	<b>£ 8.00</b>
<b>Men's Sweat Shirts</b>	<b>£16.00</b>
<b>Ladies' Sweat Shirts</b>	<b>£17.00</b>
<b>Polo Shirt</b>	<b>£11.00</b>

Choice of garment colours (please state): White, Orange and Light Blue, with the logo reproduced in Black on the left breast.

**Sizes** (please state): **S** (36"), **M** (38"), **L** (40"), **XL** (42-44"), **XXL** (46")

### Other items available:

<b>Caps</b> - White with Black piping and logo .....	<b>£ 8.50</b>
<b>Windscreen Stickers</b> - 85mm x 85mm .....	<b>£ 2.50</b>
<b>Dashboard Badges</b> - White alloy, self adhesive .....	<b>£ 3.00</b>
<b>*Grille Badges</b> - Cast alloy, white enamel - 75mm x 75mm .....	<b>£20.00</b>

### All Prices are Inclusive of Post and Packaging.

\*If you wish to purchase a Grille Badge, please e-mail: [chrispat@holwell8.freeserve.co.uk](mailto:chrispat@holwell8.freeserve.co.uk) immediately to confirm your order, including your telephone number.

**IMPORTANT:** To receive your items by post prior to the SPRIDGET 50 event, all orders **MUST** be submitted no later than **31st March 2008**.

SPRIDGET 50 regalia will also be available to order at the event or by post from: **Chris Jackson, 2 Edgell Cottages, Holwell, Hatfield, Herts. AL9 5RF**

Payment by cheque only please, payable to: 'SPRIDGET 50'



# 25 Years of the Midget and Sprite Club

## How It All Began – And We Were Not Alone!



It is early 1983, the interests of owners of Spridgley things seem just an aside to the established one Marque clubs. In fairness, they have a large audience with a wide variety of different versions to cater for. Nigel Williams has a 1967 Midget MkIII and is a less than satisfied member of the MGOC. Yours truly, Terry Horler has a 1960 Frogeye and has been discouraged by other Sprite owners from joining the Austin-Healey Club. Nigel and I work together as Toolmakers at Rolls-Royce in Bristol, we frequently compare notes on our cars and the question of which, if any, club we should join. We fail to decide on this; hence our initial thoughts of forming a club ourselves to best serve enthusiasts like us. At this time, there were plenty of Spridgley things to be found in daily use, indeed, our car park at work contained many. We felt that there could be many other owners in the area who may be interested in a club just for Spridgley things.

As we mulled over the possibilities of how to form a club, the problem almost seemed to answer itself. Reading through the then recently introduced *Practical Classics* magazine, I found something I had never heard of before, 'SMOG'. P.C. was restoring a Frogeye as their first project car so naturally, attracted many Spridgley thing enthusiasts to its readership. Within the Clubs section of *P.C.* was the listing of a new club, The SPRITE AND MIDGET OWNERS GROUP or (SMOG). I wrote away for details thinking that this could be the very solution to our desires; however, the reply was a little less encouraging. SMOG had only very recently been formed in the UK and was a new chapter to the USA based SMOG which had been running for some time. The man behind the UK SMOG was Pete Dicks. A name I recognised as the Sprite registrar of the Austin-Healey Club. Now initially, I thought that this might be a good indication, if an official of the Austin-Healey Club felt that the interests of Sprite owners would be better served by a dedicated club, then the idea must be a viable one. However, it seemed that Pete Dicks had been 'removed' from the Austin-Healey

Club for reasons I will not repeat here. On hearing this, I was concerned that SMOG may have a cloud hanging over it (Sorry, just had to get that in!). More to the point, the newness of SMOG (UK) meant that they had but a handful of members based mostly around the Midlands. If Nigel and I had any thoughts of walking into an established Spridgley thing club on our doorsteps, then this was not going to be it, not in the short term at least.

We decided to produce some flyers to decorate the windscreen of any Spridgley things we came across on our travels. We simply asked owners to contact us with a view to holding a local meeting to see if a club would be of interest. We set a date in April 1983, the venue, The Lamb Inn at Iron Acton near Bristol. Not knowing what we were letting ourselves in for, who would attend, if anyone, we were very pleased that around 10 people attended. Nigel and I introduced ourselves and explained the ideas we had. Others soon joined in with their ideas, it was clear that the room was full of enthusiasm for a Spridgley thing club. We also explained that there was already a club (SMOG) that had recently formed and that we could either become a South Western Chapter of SMOG or, become our own organisation with our own agenda and a set of objectives and rules. The latter option was decided upon. I wrote to Pete Dicks explaining this and saying that I would not be joining SMOG. This was very quickly followed by a phone call from a rather concerned Pete Dicks stating "This isn't going to work with both of us starting clubs." In the fullness of time, he was proved to be right. Our second monthly meeting at the Lamb saw some more new faces and a battle plan formed. Lindy Clifton, owner of a Midget Mk11 was only small in stature, in every other respect; Lindy would never go un-noticed or un-heard. Lindy insisted that a regular newsletter was essential to our growth. How could we produce one? Well, Lindy could of course. Lindy and John Ruderman had a Banda machine in their front room, well doesn't everyone? This was 1983

remember and the means of copying paper was more commonly with carbon paper in a typewriter for most people. Lindy wasn't going to write it however, that job she gave to me! So, we had the means, but what about a title? Our second meeting and we had no name for our little club. SMOG had already claimed the most obvious title, so we approached it from the other way. Thinking that there were far more Midgets around than Sprites, then the Midget name should come before Sprite and hopefully avoid any confusion between us and SMOG. Midget and Sprite Club was met with a slight wavering of eyebrows but when expanded to **MASCOT** as the title of the newsletter, then the decision was unanimous. A Constitution was drawn up, based largely upon existing rules of similar organisations, and an initial donation of £2 per person to help finance the newsletter, postage and other small administrative expenses. We formed a steering committee to co-ordinate activities, with only 10 people so far, then just about everyone was allotted a task.

10 people hardly make a viable club so we set ourselves a target, to recruit another 10 by the end of September. If successful, then we would make a formal start of the Midget and Sprite Club. A committee would be elected, the Constitution accepted and an initial £6 membership fee. This would reduce by 50p per month as the club year wore on as all fees would be renewable on the 1 October the following year. A practice we soon changed as it caused all sorts of confusion.

We didn't just sit around for those first few months waiting for other owners to join us. We organised runs to places of interest, treasure Hunts, Navigational events, social events; in fact, we got out in our Spridgley things as often as we could. To promote our existence, we ran a few 'Task Force' events. We all met up at a certain venue, each crew given a supply of flyers, and drove around for a couple of hours looking for other Spridgley things to unload our flyers upon. The winner would be the crew recording the greatest number of hits with additional points if a Hit subsequently joined the 'club'. In 1983, the Redland and Clifton (now to do with Lindy) areas of Bristol were hot spots for Spridgley things, lots of better off students and medics in flat land. Also good were the streets of Bath. Not so good was Weston-super-Mare, one crew got so fed up

with the lack of Spridgley things that they campaigned MGBs instead (Goodness knows what their owners thought of that). Amongst our modest number, Bob Smith and Dick Morris were active in motorsports with their Midgets, their combined experience and help led us into organising Driving Tests. These were great fun for the drivers but not so popular with our Spridgley things. We used a large car park on an industrial estate, with the owners permission of course, and a roped off section of Easton in Gordano motorway services. Fortunately, the manager was amongst our number. The popularity of these tyre smoking gearbox wrecking events led us to purchase a 1969 MG 1300 FWD saloon for the use of members. Needless to say, it didn't last for more than one event!

Having reached our target membership number, the club was officially formed on Monday 3 October 1983 at the Lamb Inn, Iron Acton. The membership voted in the draft constitution and paid their £6 membership fee. The committee was appointed as follows –

Chairperson and General Secretary  
Terry Horler  
Treasurer and Membership Secretary  
Nigel Williams  
**MASCOT** editor, producer and distributor  
Lindy Clifton

Competitions Secretary Bob Smith  
Public Relations and Social Secretary  
Tim Palmer

2 club officers were also appointed to look after:

Technical and Spares contact Nigel Furness  
Slot Car racing organiser John Ruderman

We wrote to *Practical Classics* to introduce ourselves as the new kids on the block, this produced a response from Spridgley thing owners from areas we had never heard of before. What to do? We hadn't really thought of MASC being anything other than a local club, could we operate a club that could attract members from outside the 'active area? The pivotal point would be **MASCOT**, would this be good enough in itself to capture and retain members who may not get any thing else from the club? Lindy decided it would be, I wrote harder, Lindy typed up my handwritten notes harder, John turned the Banda handle faster. If anyone else was suspected of having too little to do, they soon had paper to fold and envelopes to stuff. Committee meetings

doubled as origami evenings when Lindy arrived with wicker basket full of paper, recycled envelopes, Sellotape and stamps, all needing collating, stuffing and stamping before anyone was allowed to leave – or fall asleep! The posting of *MASCOT* was generally a last resort, any members that were likely to be seen in person were handed theirs to spare our meagre funds. I will refrain from saying anything more about *MASCOT* at this stage as this will form a complete episode in itself.

With MASC now officially on the map, SMOG realised that we were quite serious in our intentions to do things properly. Both clubs decided to meet up at Stratford-upon-Avon on the 19 August 1984. This was to be our first long range convoy, we had an impressive 8 Spridgley things stretched out along the Fosseyway, heading Northwards from base camp Bristol. What a sight we made, it was absolutely great. We were of course worried that we would be well and truly out SMOGGED once at Stratford. Other than the 8 Spridgley things from the Bristol area, we didn't know if any members from anywhere else would attend. Stratford was much closer to SMOG HQ than Bristol so we were expecting to be outnumbered. As we pulled into the car park of our meeting place, Spridgley things were appearing from everywhere. Other than our own convoy, we didn't know who was who. I asked unfamiliar faces as to where I might find Pete Dicks, all replied Who. You know, the secretary of SMOG. Sorry, we are Midget and Sprite Club – have you seen the paintwork on that red Frogeye? (Yes, I had actually). Eventually, I find Pete; in a Talbot Samba (Remember those? – No) It seems that SMOG field but 3 cars, only one a Spridgley thing. Did I feel relieved – more than that even! This was the first face to face meeting with Pete Dicks and we had a good long chat about our ideas of a Spridgley thing dedicated club. Despite our similar interests, we went about things very differently. SMOG was very into the buying and selling of spares with much less accent of eventing than ourselves. *MASCOT* was certainly a few pages ahead of SMOGGERINGS which ultimately, ran into difficulties. We agreed to keep in touch but with the lack of any proper rules and regulations adopted by SMOG and the financial arrangements with their Spares trading activities, we were cautious about their standing.

This made us realise that almost anyone could call themselves a club yet have little regard or knowledge of the responsibilities involved. We were careful to try and do things properly. We had a set of Rules and Regulations (Constitution) which set out how the club should run. We had a properly set up club Bank account, we even had Public Liability insurance. Clubs Affiliated to the RAC (Now MSA) have to comply with a standard set of Regulations, as we were not predominately a motorsport orientated club, we saw no reason to seek affiliation to the RAC. As a young and very small club, we were anxious that some recognised body might endorse our existence as a proper bonafide organisation. It was rather like a plumber or gas fitter being Corgi registered! As we chose not to go the RAC route and we were not aware of the organisation that became the Federation of British Historic Vehicle Clubs, an opportunity to gain that desired rubber stamping arrived in October 1984. We were invited to attend a meeting at the Clarendon Press Centre in Oxford along with 24 other clubs who catered for BMC vehicles. The idea was to set up an Association of BMC Car Clubs. I pictured "Midget and Sprite Club", a member of the Association of BMC Car Clubs on our headed paper, sounded good. Instant credibility without having to sit an exam! 19 clubs attended and each introduced themselves along with their membership figures. I had thought of sliding under the table as our sub 50 membership didn't stack up to well against the MGOC's 30000. Somehow, I got away without divulging our meagre numbers and spared the others a good laugh. Although there were some very good ideas and intentions in the setting up the A of BMCCC, they were not at all concerned about the credibility of member clubs. No doubt that was already an assumption. Certainly, they were not going to set any club standards or get involved with the ways member clubs operated. The main function seemed to be organising a National BMC Rally and spares co-ordination. Good things in themselves but the real crunch came when a membership fee of £15 per club was set regardless of size. £15 spread amongst 30000 members of the MGOC would go unnoticed, £15 across 50 members of the MASC, well, who is getting a better deal here I thought. We discussed the matter at some length back within the 4 small walls of MASC.

Yes, it would be nice to be recognised and a part of something that carried some clout, but did it? It was a close run thing but on the official formation of the Association on the 14th of April 1985, MASC declined membership.

Perhaps we were wrong to think we could 'buy' a slice of credibility and approached this from the wrong direction. However, our true values were worth much more anyway. We certainly couldn't afford to be complacent about the standing of MASC as we had a direct competitor in the form of SMOG. Although it might have been nice to have the field to ourselves, SMOG's existence ensured that we kept trying the best we could.

Size wise, SMOG had a larger membership than MASC. Their membership fee was £8 compared to our £6. Despite these advantages to their coffers, they ran into trouble with producing SMOGGERINGS. They asked to meet us again but this time, just club officials. We met at a Pub in Worcester on the 4 May 1985. Representing SMOG were Pete Dicks and Barry Harber and from MASC, Nigel Williams, Dick Morris and yours truly. Pete explained that SMOG was experiencing difficulties and perhaps each club could help each other out where possible. To cut a long story short, they wanted us to distribute **MASCOT** to their members with a SMOG content. Offers like this don't take a lot of thinking about but we did have a simple answer. As SMOG still did not have a proper constitution and, we felt, proper accountability, we could not link our names or services. To leave it on a positive note, we supplied a copy of our Constitution and urged them to adopt something along these lines before we could even reconsider any future relationship. We strongly opposed the idea of using membership subscriptions to wheel and deal in either new or used spares. Most clubs ran a separate and quite often voluntary spares fund for such activities. Our subscription was based on providing a properly accountable service to members that would not be at risk due to the vagaries of the buying, storage and selling of spares.

Whereas we used subscription fees for the production of **MASCOT** and general expenses, SMOG bought and sold parts as they deemed fit, we were worlds apart on this one.

Our next coming together with SMOG was at the BRITISH MOTORING FESTIVAL held at Cofton Park on the 28 to 30 June 1985. Our own membership was growing in the Midlands and this was an ideal opportunity to get to know them. John Ruderman booked a prime spot in the centre of the show ground for the 11 cars expected to attend. John and Lindy arrived on the Friday to set up only to find that we had lost our prime location. Evidently, SMOG were also at this show and asked the organisers to have our location moved next to theirs, right on the edge of things. Although this kept all Spridgley things together, it was not what we had in mind to best promote our club. Visitors asking about membership were confused as to which club they were talking to whilst almost being fought over by opposing club representatives.

Although our thoughts of being recognised by a large and creditable organisation had not materialised, an opportunity presented itself to become involved with something else that was bigger than we were. In 1985, the Austin A30/35 Club held their annual Rally at Longleat House in Wiltshire. This was a big event and a great success. It so happened that one of the organisers, Chris Hilton, was a Midget owner and MASC member. Chris had the idea that this event could easily be repeated but rather than just the A30/35 Club, to involve other local BMC orientated clubs too. A meeting was called for representatives from the A30/35 Club, MASC, Morris Minor Club and Austin A40 Farina Club to hold a joint Rally at Longleat in 1986. None of the local branches of each club were big enough or had the resources to organise and support such an event. However, combined, we suddenly had the opportunity to put on a major event that would otherwise be beyond the scope of any of us. This gave us the chance to offer a National Rally to MASC members with minimum risk financially and much help from our fellow organising clubs. So, the first GREAT WESTERN RALLY was held on the 14 & 15 June 1986 and became an annual event, other than a move to Bowood House in later years, for the next 20 years. Sadly, this event has now ceased, fallen victim to increasing red tape and financial risk, but it was good whilst it lasted.

Communications between MASC and SMOG had lapsed for quite some time and then on

the 4 April 1988, we took a stand at THE ALL ENGLAND AUTOJUMBLE at St Martins Rag Market in Birmingham. This was to be our next and rather unexpected meeting with SMOG. The SMOG stand was represented by Jonathan Whitehouse Bird and Warren Cox. Evidently, SMOG was put on hold at their March 1988 AGM as affairs needed to be reviewed. Jonathan and Warren had taken over from Pete and were planning to re-launch the club in October.

With fresh faces now at the helm of SMOG, we invited them to join us at a run we were organising to Bourton-on-the-Water on the 11 September. Jonathan was the sole representative from SMOG on that day and we spent a nice afternoon discussing where both clubs were at the present time. Quite clearly, Jonathon and Warren were having problems in re-launching SMOG whilst MASC was quietly getting on with it. Both clubs had now been running for around 5 years, SMOG had around 50 members whilst MASC had over 160. Clearly, after 5 years and a combined total membership of just 210, was there really a need for two clubs? Considering the effort and

responsibilities required to run a club even of modest dimensions, then Pete's prediction that it was not going to work with two clubs now seemed correct.

Next month, I will relate how the dilemma was resolved. As to which club survived and which one didn't, well, you will just have to wait until next month to find out. (Hang on; I think you may be well ahead of me on that last bit)

**Terry Horler**

### **Where It All Began**

The very first meeting that led to the formation of the MIDGET AND SPRITE CLUB was held at the LAMB INN, Iron Acton near Bristol in April 1983. To mark 25 years of this historic occasion, MASC members are invited to meet here once again on the evening of Monday the 21 April 2008. Iron Acton is just off the B4059 opposite the junction of the B4058 to the north east of Bristol. From the junction of the B4058 and 9, (Traffic lights) head southwards into the village, The Lamb is approximately 100 yards from the traffic lights on the right hand side.

## **D J Grove Restoration**

*Phone/fax:*  
01256 768678

Hampshire  
based,  
worldwide  
customers

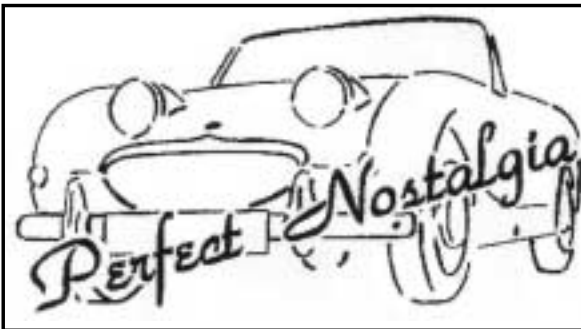

For friendly expert advice from an ex F1 engineer and Sprite and Midget specialist, with a longstanding reputation in concours, race preparation (i.e. Goodwood Revival), complete restorations, servicing, chassis rebuilding, and obscure parts traced.

**Frogeye, special body, Speedwell and Sebring Guru**

### **STOP PRESS!**

In the workshop,  
2 Frogeye chassis  
rebuids, original  
Speedwell rebuild,  
modified race Sebring  
construction  
Car supplied for Ch4  
TV filming

# Letter to the Editor

## Special Sprites

7 January 2008

Dear Barry

It was most interesting for me to read the reproduction *Autosport* advertisement for John Venner-Pack's Speedwell Sprite, VP 7 in "From the Archives – 1960" in January's *MASCOT*.

In the course of the research for my forthcoming book on the Frogeye Sprite, I spoke to John and his wife Jane at the beginning of December. He was surprised that there was still interest in his racing exploits of 48 years ago and recounted some amusing anecdotes, which I will be using in the book. John told me that he had sold the car via *Autosport* at the end of 1960 but did not remember when. You have



*Peter Preston's Speedwell GT*

been able to date it as 6 December. I had already tracked down and spoken to the buyer, Barry Wood – later of Shapecraft Elan fame.

Barry raced the Speedwell in 1961 displaying the contrived registration number RAM 36. At the time he was working for Paddy Gaston at Albany Park Service Station and ran the ex-Venner-Pack Speedwell as the sister car to Paddy's all-conquering Speedwell, RAM 35, later raced and rolled by John Britten. I have been in touch with Paddy's daughter who has kindly lent me some photographs of RAM 35 and the Venner-Pack's also expect to unearth some of VP 7. Barry has already sent me some of it as RAM 36. Hope it's not getting too confusing. In the same section of *MASCOT* you showed an ad for Gaston's "Sprite Centre". This was the first time I had seen or heard of this alternative trading name.

In the course of my comprehensive research, I have spoken to about 200 people and accumulated a great deal of Frogeye information. However, I still have some gaps



*Brian Archer's YOF with Star Sprite bonnet*

in the histories of a number of the Mk I Sprites that were rebodied by other companies. Alexander Engineering built two: 777 EBH and RWV 661. Speedwell created just over 20 of their coupes similar to VP 7. I would particularly like information on 137 VMX (Tony Coakley), 60 XMX (Tony Hegbourne) and UGU 874 which surfaced for sale in *Autotrader* about 10 years ago.

Does anyone know the current whereabouts of Peter Preston who raced 5755 MM under the Angus Racing banner in historic events during the early 1990's?

About half a dozen cars ran with a Star front including 142 FBH that was raced but I have

been unable to find the name of the driver. I have spoken at length to Douglas and Tony Wilson-Spratt of WSM fame, but again I am still missing some history on examples of this model, a number of which were never registered for the road.

If readers owned/have information regarding **any of these very special Sprites** or possess photographs, I would appreciate hearing from them as soon as possible. I expect to finish writing my text by the middle of February and the book is due out before the end of the year. I can be contacted on 01892 862656. Thank you for your interest and help with this Barry.

**John Baggott**

## Progress on JJO



**H**aving returned from Angouleme with a seized engine AND gearbox, I proceeded to strip them out and my first step was to take the box over to Bill McDonnough at Hardy Engineering. He was able to very quickly un-jam it but felt it should have a spacer fitted to prevent it happening again.

Then we got talking about the availability of close ratio straight-cut gear sets and in the end he has re-built it with these new gears in. I can't wait to try it out. I then stripped the motor down finding a mass of metal particles in the sump which didn't bode well. What had happened was that the centre main bearing had failed and as I continued to punish it despite having little or no oil pressure, one half of the shell bearing had become so thin it slipped round behind the other so that they eventually welded themselves together.

Amazingly the crankshaft wasn't too bad and Colin of Southern Rebores reckoned he could grind it 5 or 10 thou and it would still be OK. However he did kindly offer to sell me a standard Midget crank he had on the shelf so I took him up on it. The block was damaged and had to go to specialists Gosnays, in Romford, Essex to be line-bored. They did an excellent job on it by the way. We still don't really know why the engine had low oil pressure when rebuilt last year or why it got worse over a period of time, but I have now fitted a centre main bearing strap to make that area stronger. I am also fitting an adjustable oil pressure relief valve (from MiniSport) and an oil temperature gauge so I can keep a closer eye on things.

The engine is gradually coming back together as you will see from the attached photo of it on its stand, and I hope to have it back in the car in a week or two. Then a few quiet and calm miles to run it in I think.... The cylinder head tended to run hot from word GO and I wonder whether the exhaust wrap I put around the exhaust manifold might have caused, or contributed to, that. I wonder if anyone has any thoughts or observations? Hopefully JJO will soon be out again for some track days, sprints, hill-climbs and in September another visit to Angouleme.

**Martin Ingall**

**Do You Have Anything Else  
Exciting in Your Garage?**



*This example sent in by Paul Beardmore from Stone in Staffs, Memb No 1900*

**AUSTIN HEALEY  
SPRITE**

**£586. 12. 1**

INCLUDES  
**£101. 12. 1**  
P. TAX

**'Extras' at additional cost**

Aug 1958

# Dutch Report



Hello again and a happy 2008 to you all! This year promises to be a great Spridget year with the Sprite's 50th birthday and MASC 25th birthday. In Holland we have special Spridget celebrations too. On the 1st of June the Austin Healey Sprite club organizes their 5th (Jubilee) ALL SPRITE RUN (which is also open to every Spridget) in the area of National Nature Reserve "The Betuwe". As in previous years, great organisation and fantastic scenic roads.

In the first weekend of September (actual date will follow) there will also be the 5th (Jubilee) Spridgetrun in Overdinkel on the German/Dutch border. The organisers really know how to party with your Spridget so we can expect something very special this year!

But to attend these events I really need to work on my Midget first. The list of things to do is too long to print in *MASCOT* but it's serious this year (as in all previous years but I guess that's all part of the happiness of



owning a Spridget). The engine is coming out again for a change and by the time the events-season begins I'll probably have acquired some new scars and lost a couple pints of blood. But hey, working on your classic car keeps you poor and out of jail so it's not all that bad is it?

For more info on the Dutch Spridget scene or just a beer and car-chat [ariedebest@planet.nl](mailto:ariedebest@planet.nl)

**Arie**

# Bristol Area Report

2008 got off to an earlier start than expected. Although our first meeting was planned for the second Wednesday of January, several of the Bristol group participated in the Classic and Historic Motor Club's New Year Trundle on Sunday the 6th of January. Paul and Colin were at the start at Wrington in their Frogeye Sprites, Geoff and Marie came along in a recently acquired Lotus Elan whilst I turned up as navigator in an Anglia. Our leader, Alan Lo, also a member of C & H Motor Club, stayed warm and dry elsewhere! 45 cars and some 110 people made this rather a large event, excellent route, countryside and followed by a 3 course lunch – good start to the New Year.

Club night saw Paul, Phil, Andy, Colin, Alan and me turning up to the Rose and Crown at Pucklechurch. Alan announced his retirement as Area Organiser, followed by a frantic scuffle as to who should take over. After much debate, careful thought and money changing hands under the table – I lost out. As the Area Organiser for the region some 20 odd years ago, the others seemed to think that my previous experience might count for something. Time will prove them wrong! Actually, with Alan out of office, this now leaves me free to write exactly what I like each month. No more being instructed how many mentions Alan must get and how good he is at everything, I can now tell the truth as I see it!

Unfortunately, the time spent in avoiding the struggle for absolute power at our January meeting left us precious little time to discuss much else. However, we plan a getting together on Monday the 21 April at the LAMB INN, Iron Acton to celebrate 25 years of the very first meeting that led to the formation of MASC. The Lamb was the early home of the Club and hosted all the initial coming together of minds that got the club started. We hope that many of the characters of the very early days will be able to come along and we extend an invitation to all to join us. I know a Monday is not good news to those from further afield but the Lamb is very busy at weekends now. More on this next month.

Don't forget, the Bristol group meet on the second Wednesday of the month at the Rose and Crown, Pucklechurch and attendance by Spridgley thing is not mandatory. In closing, a big thank you to Alan from all the Bristol Group for leading us and keeping us on the straight and narrow during his term of office. I only hope that I am worthy enough to follow his shining example of fearless leadership and wisdom.

(Yes, I know the meeting noted the 7 April as the date for the meeting at the Lamb Inn, but I'm in charge now so I can change my mind if I like, OK?)

**Terry Horler**

## Cambridgeshire Report

Pat and I missed the December Mad Cat night since we were on holiday, although come to think of it most years we have not held the pub night in December, preferring instead to replace it with a Christmas meal around the same time. This year the Christmas meal was pulled forward to late November, hence it seemed natural to hold the pub meeting on the normal day. Since I could not attend the December meeting I had to dash off the report very early and very quickly before we left for France, hence the error in the last paragraph (surprised HTJ didn't pick me up on it), sorry guys I will try harder. Another consequence of missing the meeting was that I had to press gang Diane into updating me with the goings on at the December meeting (thanks Diane it's appreciated), see below.

It was a cold December Sprite night. We (Nigel and Diane) arrived early for the pre meeting meal, as always it was very good. The log fire was burning brightly in the Mad Cat giving a lovely seasonal feel to the old pub, at one point Nigel came to the rescue, as a large log fell out of the fireplace sending smoke through the pub, so our Sprite night was nearly over before it had started!! However Nigel quickly contained the situation by replacing the log before any real damage was done.

We were soon joined by Graham, Mick and Dave, it was like a mini Cambridge gathering as our Captain Dave and Pat were in France

and our other Peterborough duo Hubie and Sally were unable to attend. We received many suggestions and ideas for both car and off season events, one being a bowling rematch in Peterborough. Other suggestions will be put forward to our Captain Dave at the next meeting.

Graham was given good advice from Mick and Dave on how to fix his sick Sprite since unfortunately a month earlier the head gasket blew but after replacing it he found water in the oil. There was some debate as to whether this was due to the head gasket or something more sinister. The collective wisdom from the group was not to run the engine with the water still in, but to flush it out, install new oil, restart the engine and run for a short time before rechecking the oil for water contamination. What to do next if water was still present in the oil provided a good talking point. Let's hope it all goes well and the little white Frog is soon out on the road again splattering the fronts of unsuspecting followers with Castrol R.

Poor Mick still had his wrist in plaster from a recent incident with his new engine (so Spridgleting can damage your health) and to make matters worse he had realised that the engine he had acquired was not the large capacity beast he had intended to fit. However in the end he decided it was powerful enough anyway, and he would press on with the

rebuild once his wrist is back in working order. It looks like we are all busy getting our Spridgets ready for the big birthday bash.

Another prominent topic of conversation, while the landlord plied us with complimentary food, (what a nice friendly place the Mad Cat is) was the recent night at the dogs which everyone agreed was a brilliant night, well done Hubie and Sally for organising it.

As I type this the deadline is in danger of overtaking me so I will have to update you on the more recent Cambridgeshire exploits next month (which is almost the start of the new season), apart from mentioning how brilliant it was to meet Fred and Chris (I think, I am terrible with names), our latest new members,

at the January Mad Cat meeting. Fred and Chris have an Austin Sprite (one of the few) and needs a little help with some points of originality for these rare cars, and lucky for them we have just the man among our ranks to help them out (don't we Rob). I have always prided myself that we have at least one of almost every Midget and Sprite model, mark or derivative in our area, with the exception of an Innocenti, although I think one of Barry's sometimes lives in Cambridgeshire, but it looks like we are starting to get at least a brace of each, brilliant!

See you all at the Mad Cat

**Dave Dixon**

## Linc'slot

Eight of us gathered at the White Hart for our pre Christmas Lunch on Sunday 16th December. At least Phil and Annie had the bravery to arrive in style, coming as they did in their really nice Midget. Hats and scarves were donned, I noticed, for their leaving after the meal. Not surprising really as it was rather a cold day and the meal was uncharacteristically rather cold too. We did not complain about the food at the time and so I expect it is rather bad form to mention it now. Oh well.

Tim and Jill came in their honorary Spridget. That is their Austin A35. At least it has the A Series engine, and it keeps them warm and dry. They do travel the furthest after all. I'm not saying what the rest of us arrived in except for Three Pom Pom Pete. He had been on one of those Santa Runs through the streets of Skegness in the morning, for charity, bless him. But he didn't have time to change out of his Santa suit before coming to lunch. Other diners kept handing him letters with lists of presents they wanted. All very amusing. This year he may be known as One Pom Pom Pete.

Some of us visited Pete and Mary at their home for New Years Day. A lovely meal thanks, and a trip to Mablethorpe to see the ridiculous looking new style beach huts being shown off there. One depicted a cocktail in a glass. The other looked like a huge teardrop

with foot and hand holes up one side. Still, at least we could hardly see them through the thick fog on the beach. We could only just see the edge of the sea. It was almost spooky. Back at the ranch, we examined Pete and Mary's latest acquisition, a very nice green Morris Minor Van. Fortuitously it came with some lettering on the sides which perfectly suited Pete's line of work. All he had to do was add his phone number.

Personally, I am hoping this will be a better year than last. I was very disappointed to miss our two main events last year, through no fault of my own. Although we did have a very nice run round Rutland with the guys and gals from Yorkshire, Cambridge and the Home Counties North West. Thanks chaps and chapesses.

We also had a great day out at Cadwell Park watching some Midgets and other classics racing. Thanks very much to the other members of our happy little band here in Lincolnshire. Even if we do nothing else, we always have the monthly meeting to go to. Remember, all friends, old and new, are welcome at the pub.

February 7th is the next meeting.

Hopefully some of us will get to Spridget 50 in May. If so, see you there.

**Brian**

# Warwickshire Area Report

Happy New Year to everyone from the Warwickshire Area. While our prime objective is looking forward to a New Year of happy motoring, and planning this year's calendar of events, we have to mention the two events held during December of last year. The first was our usual Christmas Dinner at the Green Dragon, where each year we become more in danger of exceeding the capacity of the room. Having made an early start, the dinner was consumed in time to be followed by a quiz, which is also becoming a welcome annual event kindly provided, along with the prizes, by Steve and Carol Farr. This year there were cryptic clues associated around various makes of car, very appropriate. There were joint winners Stuart, Sybil and the Smith family.

Alan and Rosemary Couch had organised an end of year run for Sunday 30 December, when the weather was bright, dry and crisp. However, there was a notable lack of Spridgets with six of the eight couples using their modern cars or alternative classics. Ann and John Platt were in their Midget with a hard top, and Chris and I were not only in our



*John and Ann in their Midget*

Sprite, but also with the hood down!!! The route started from the Green Dragon, our usual meeting place, and followed country roads to Halford where we joined the group, as it is close to our home.

We then drove to Burton Dassett Country Park with its easily recognisable folly, for a walk and breath of fresh air. We drove on past Edgehill, Upton House and Hook Norton, without stopping to sample the local brew, and followed the Cotswold roads to Burford, where we did stop for lunch at the Bull Hotel, where they appeared to have turned slow service into an Art form! Having finally consumed our lunch, the group set off to investigate more Cotswold countryside not finishing until it was dark, arriving at our favourite stopping place,

The Bell in Moreton, for a final drink and farewell. Our thanks go to Alan and Rosemary for a superb route, finding some roads new to us all and incorporating some beautiful scenery.

Our next event is the **MG Show at Stoneleigh on Sunday 24 February** where we have a club stand. Geoff Hunter has booked an Autojumble stall and kindly offered to sell any unwanted spare parts, so now you can clear out your garages and create some space whilst raising money for your next project.

***Chris and Sheila***





## Yorkshire Report

A chilly January meeting saw us return to The Crosby at Thornton-le-Beans near Northallerton, where a fantastic turnout of 28 tucked into a Spridget-themed meal (frogeye soup, fishy sprite and a Silverstone, anyone?) prepared by the award-winning kitchen.

Not having far to travel (only a few doors down the road), “Sebrina” and Sarah’s MG 1100, “Mary”, were on the forecourt mid-morning, and were soon joined by a trio of 1500 Midgets, a Rover Mini, and two modified Spridgets. Not bad given the recent snow and salty roads!

Amongst the usual familiar faces, several made the long trek from Tyneside, including Jordan and Tanya (without loW Frogeye which is still recovering from its little accident last year), and Lisa and Rob in their 1500, which also saw some action on MG Cumbria’s

Christmas Cracker, a fantastic one day run in the Lake District, which was very wet and included a very deep ford at the rear of Blencathra.

Guy and Hazel Weller also joined us on that highly entertaining event, and you can see them crossing the ford in their rare Austin Sprite in the photo.

Mark’s newly restored Frogeye was being kept tucked up safely, as it is being used for filming at present, but Martin and Gail turned in a wonderfully noisy rat-look Sprite, complete with Cosmic alloys, shabby matt black paintwork, and a bad-boy rorty exhaust! Another addition to his business fleet.

It was also good to see Yorkshire area’s club hero, Simon Parson, who has completed 8,000 *competitive* miles in his rally Sprite in the last 12 months (wearing out the gearbox in

the process). This is in addition to commuting from the Vale of York to Edinburgh every week (albeit not in a Spridget). Now there is a man who loves his mileage!

It was also good to catch up with Ken and Pat who braved the weather in their yellow 1500; Robin and Jill with new puppies; the Higgs family; Andrew Harrington who was dreaming of the new engine for his 1930s J2 Midget; Andy B who was checking out fuel and brake line routings, as his Frogeye restoration ploughs ahead; Tony who was checking out bodywork issues for his Toyota powered Midget; and Arthur and his pals. New faces John and Carol also joined us from County Durham and are looking forward to getting their Sprite out in the spring.

L'Amicale Spridget are keen to invite UK Spridgeteers to join them at their stand at the Le Mans Classic 2008. If you are interested in joining us, please contact me or Anita, although she may be out of action for a little while.



Sadly Mark and Anita were involved in a nasty car accident in a Mini near York in early January, in which Anita had to be cut out of the car, and she has suffered some serious injuries to her pelvis. Despite this, she still proof-read this report through the morphine! We all wish her well and a very speedy recovery.

**Tim Saunders**

## Somerset Area Report

I am writing this report as the winter storms drive against my patio windows with the thought of open top motoring a very distant proposition. However, I am confident that in 6 to 8 weeks the spring weather will arrive and we will once again venture out in our convertibles. Let us also hope the English summer does not live up to expectations and produces some warm sunny days to allow the Somerset group to enjoy spridget touring and good pub too.

This year will include attendance at The Spridget 50 at Gaydon, Branscombe Show and The Culmstock Classic to name a few.

We still meet at The Lord Nelson Norton sub Hampden the last Thursday each month and you are welcome to join us. Please feel free to ring me on 01823 412004 or by e-mail on david@alpinab3.orangehome.co.uk

**David Bearne**

## Lee Reed Standing Down in Essex

Nigel/Barry

Could you please remove my name from the club records as the area rep for Essex. This is due to the fact that I have never been able to give this position the time it needs due to my mainly large working commitments, and also I have come to the decision to sell my Midget

and having one is a bit useful to run an area for the club.

I however will probably stay a member of the club as the members are great bunch of people and the mag is a good read.

**Lee Reed**

# South East Area Christmas Meal

The third Tuesday of December 2007 found South East Area members converging on the Kingswood Arms, Kingswood, Surrey from the far reaches of Kent, Surrey, and Sussex, for the annual Christmas meal.

I was amazed to have enquiries, from people wanting to come, right up to the day before. Folks if you want to come on events you have to make your mind up early to avoid disappointment as for instance our 2008 LeMans Classic Tour in June, with nineteen participants, was fully booked, with two exceptions, by the end of July 2007. It's the early bird....

John Clark drove *seventy miles*, each way, from Herne Bay, in Kent, to be with us. Was this the farthest travelled? Peter Gardiner won the prize for having brought his Midget to Surrey Club Nights more than anyone else this year. I apologise for not making a formal presentation during the course of the meal. I rather unceremoniously 'presented' Peter with his bottle of 'Vin Rouge', by thrusting it into his hand, whilst he, and others, were having a pre meal drink at the bar. This came about as Pete

and Hills had kindly sourced for me a Type 9 Sierra gearbox. I needed both hands for transfer from one car to another, in the car park, outside. (I am led to understand that Type 9s are now getting scarce and will become scarcer in the coming months as a particular class, in a discipline of motor sport, adopts Sierra engines and gearboxes as its standard).

After the food, whilst coffee and mince pies were taken Chris Harding stood to give us a resume of what to expect on our 2008 May run. This run is to be held on the weekend 3-6 May 2008 when we are to be based in the New Forest. So far eighteen double and two single rooms have been taken. Two double and one single room remain for anyone wishing to join us on this popular event.

Thank you to each and every one who attended the Christmas Meal and especial thanks to David and Chris Wright for organising this event.

**Alan Anstead, S.E.Area rep.**

Mail to [alan.anstead@btoopenworld.com](mailto:alan.anstead@btoopenworld.com)  
Tel / answer phone 01322-384050

## Market Place

Adverts to Alan Lo

23 Charnell Road, Staple Hill, Bristol, BS16 5NE  
email: [alan@mobuzzing.net](mailto:alan@mobuzzing.net) Tel: 0117 9572617

### For Sale

**1961 Austin Healey Mk1 Sprite (Frogeye, reg. 1100WY)** Stored in my garage since its MOT expired and house move coincided in 2005. New steel body parts, resprayed, new springs and hangers, chrome work etc by Northern Healey Centre a few years ago, at great expense, (photos available). Used regularly till Sept. 2005. Just don't have the time or flexible body to work on it and get it back on the road. Price £3750.

Full details available from  
**Graham Reed, tel 01423 797988,**  
**Knaresborough, North Yorkshire.**  
Email [gereed@btinternet.com](mailto:gereed@btinternet.com)

**MK1 Sprite Radiator** £40 948 Cranshaft  
standard journals £50 Lightened Flywheel  
£30 Con rods (4) C/W Pistons £10  
**Reg Bradbury, tel 01889-271037 (Staffs)**





The world's **largest Austin Healey** parts specialist

• Parts for both Healey and Sprite Models • Special Sale Items • Technical Tips • New Items



## BADGES

XBAD131

These are a top quality reproduction of the original, made in the U.K. and not to be confused with the vastly inferior foreign imports.



XBAD103

XBAD117

- Part No: XBAD101 MK1  
Bonnet Badge ..... £18.75
- Part No: XBAD103 MK2-MK4  
Bonnet Badge ..... £10.95
- Part No: XBAD117 MK1-MK3  
Boot Badge - Midget ..... £9.95

## REAR AXLE

Part No: XRAX132  
MK1-MK4

Crown Wheel & Pinion (3.7:1)

£147.50



## SIDESCREENS



- Part No: XSID105  
Surround Rubber R/H ..... £9.95
- Part No: XSID106  
Surround Rubber L/H ..... £9.95



Manufactured and assembled by ourselves, these reproduction sidescreens are of superb quality and fit. They are supplied with perspex and seal and are sold separately.

- Part No: XSID101 - MK1/MK2  
Side Screen R/H ..... £79.50
- Part No: XSID102 - MK1/MK2  
Side Screen L/H ..... £79.50

## HOODS



- Part No: XHOD153 - MK1  
Hardtop Clamp Chrome ..... £28.50

## WHEELS



- Part No: XWHE130 MK1  
A.H. Hub Cap ..... £13.95

## HEADLIGHTS



- Part No: XLTG101 / XLTG102  
Head Lamp RHD / LHD ..... £44.50 each

## GRILLES



- Part No: XGRL101 MK1  
Grille - Chrome Plated ..... £139.50



- Part No: XGRL115 MK1 - MK3  
Grille - Midget ..... £115.00

## CLUTCH PIPES



- Part No: XCLU155 - 948CC-1096CC  
Clutch Pipe R.H.D. ..... £10.55



- Part No: XCLU158 - 948CC-1096CC  
Clutch Pipe L.H.D. ..... £10.95



Our Catalogue is now available on mobile, compatible with all MOTO fully featured smartphones and tablets with the NEW APP!

Tel: 01926 817181



AH Spares Ltd, Units 7 & 8 Westfield Rd, Kineton Road Industrial Estate, Southam, Warwickshire CV47 0JH

**AH**  
SPARES  
LIMITED

**www.ahspares.co.uk**

Fax: 01926 817 868 Email: [sales@ahspares.co.uk](mailto:sales@ahspares.co.uk)



ask about our exclusive  
Midget and Sprite  
Club Packages

CLASSICLINE  
Insurance

# do you miss the human touch?

If you're anything like us,  
you'll be fed up of typing, clicking and  
generally struggling with computers...



...that's why at ClassicLine we have a  
small, friendly team of real people,  
ready to talk to you and make sure that you  
get the best deal for your car insurance.

call  
**01455 639 000** ...and talk to  
a real person!

visit  
**[www.classiclineinsurance.co.uk](http://www.classiclineinsurance.co.uk)**

Authorised and regulated by the Financial Services Authority